

Copyright © 2000 by Levent Acar. All rights reserved. No parts of this document may be reproduced, stored in a retrieval system, or transmitted in any form or by any means without the written permission of the copyright holder(s).

1. For the following open-loop pole/zero locations, sketch *expected* root-locus diagrams. Make reasonable guesses for the features, and show the expected shapes of all the root-locus branches. (24pts)

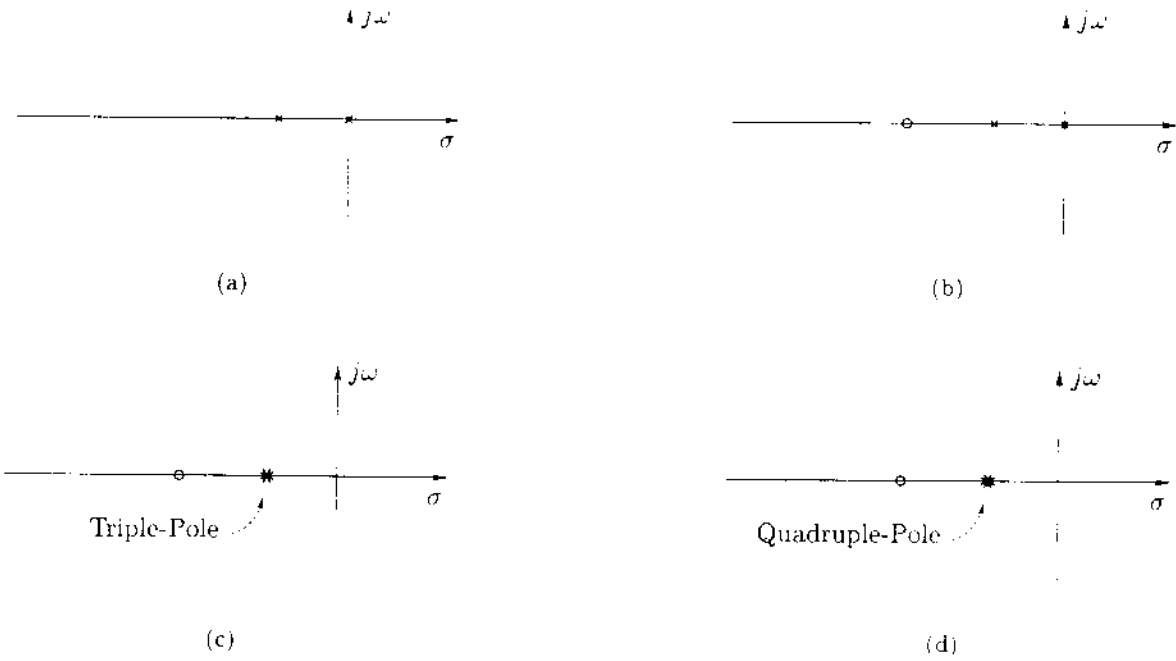

2. Sketch the location of the closed-loop poles for the following feedback control system for $K > 0$. Show all the important features. (25pts)

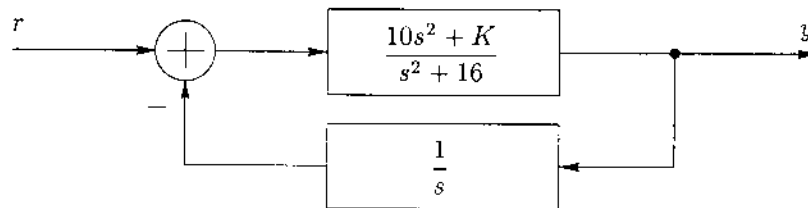

3. For the following feedback control system, design a PID controller; so that the steady state error for a step input is zero; and such that the maximum percent overshoot is less than 5%, and the 2% settling time is less than 0.5 second. (26pts)

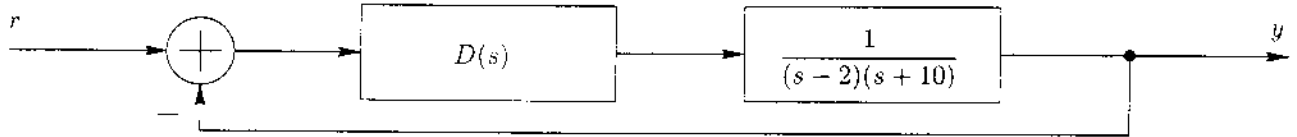

4. For the following feedback control system, design the simplest proper controller, such that the 5% settling time is 0.2 second, and the peak time is approximately 0.15 second. (25pts)

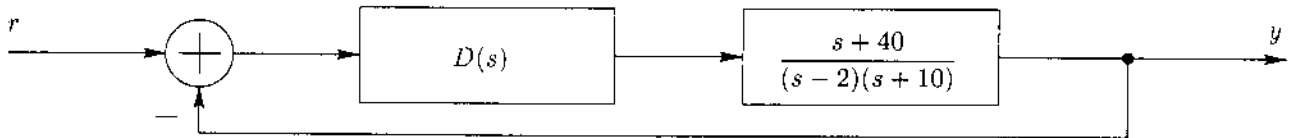

Copyright © 2000 by Levent Acar. All rights reserved. No parts of this document may be reproduced, stored in a retrieval system, or transmitted in any form or by any means without the written permission of the copyright holder(s).

1. For the following open-loop pole/zero locations, sketch *expected* root-locus diagrams. Make reasonable guesses for the features, and show the expected shapes of all the root-locus branches.

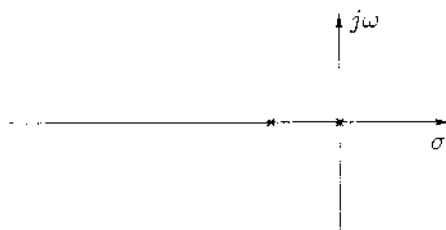

(a)

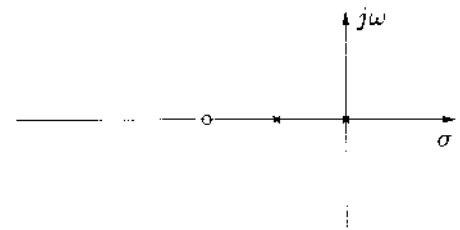

(b)

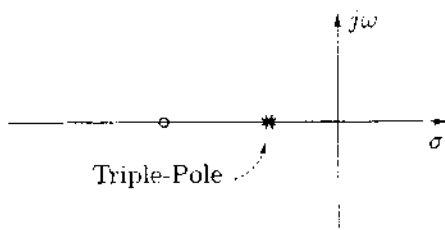

(c)

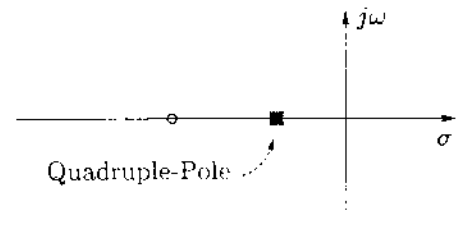

(d)

Solution:

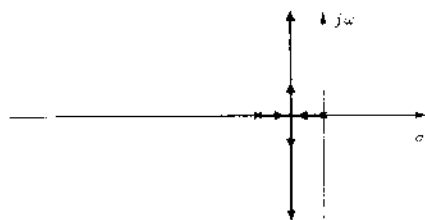

(a)

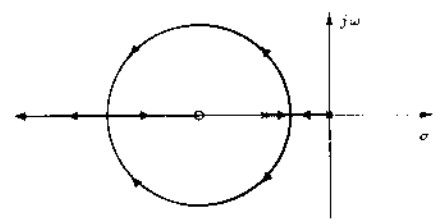

(b)

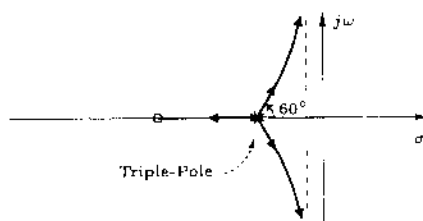

(c)

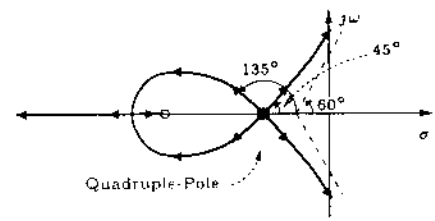

(d)

2. Sketch the location of the closed-loop poles for the following feedback control system for $K > 0$. Show all the important features.

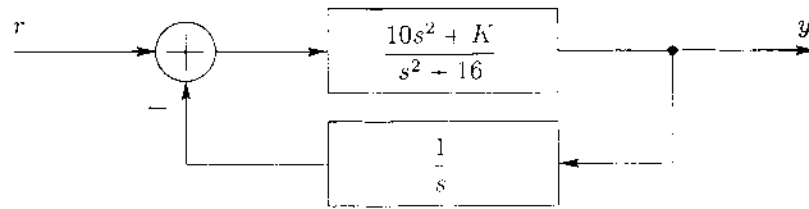

Solution: The sketch of the location of the closed-loop poles is the root-locus diagram. However, in this case the open-loop gain of the system is

$$G(s)H(s) = \frac{10s^2 + K}{s^2 + 16} \cdot \frac{1}{s} = \frac{10s^2 + K}{s(s^2 + 16)}$$

where the root-locus variable K is not a multiplicative coefficient of the open-loop gain. So, we need to convert the problem into the conventional form while preserving the location of the closed-loop poles the same. The closed-loop poles are obtained from the characteristic equation, where

$$1 + G(s)H(s) = 0,$$

or

$$1 + \frac{10s^2 + K}{s(s^2 + 16)} = 0.$$

$$\frac{s(s^2 + 16) + (10s^2 + K)}{s(s^2 + 16)} = 0,$$

$$s(s^2 + 16) + (10s^2 + K) = 0,$$

$$s^3 + 10s^2 + 16s + K = 0.$$

We need to regroup the characteristic equation, so that the characteristic equation is in the form

$$1 + K \frac{n(s)}{d(s)} = 0.$$

for some polynomials $n(s)$ and $d(s)$. So,

$$s^3 + 10s^2 + 16s + K = 0.$$

$$(s^3 + 10s^2 + 16s) + K(1) = 0.$$

$$\frac{(s^3 + 10s^2 + 16s) + K(1)}{(s^3 + 10s^2 + 16s)} = 0,$$

$$1 + K \frac{1}{s^3 + 10s^2 + 16s} = 0.$$

Therefore, the new open-loop gain

$$G'(s)H'(s) = K \frac{1}{s^3 + 10s^2 + 16s} = K \frac{1}{s(s+2)(s+8)}$$

generates the same closed-loop poles as the original open-loop gain, but the open-loop gain $G'(s)H'(s)$ of the new system is in the usual form for the generation of the root-locus diagram. In other words, the locations of the closed-loop poles based on the open-loop gains $G(s)H(s)$ and $G'(s)H'(s)$ are identical, however we can use the regular root-locus drawing techniques on the primed system.

First, we sketch the pole-zero locations and the real-axis portion of the root-locus diagram. Then, we decide the important features to be determined.

Need to determine:

- Asymptotes, and
- Breakaway point.

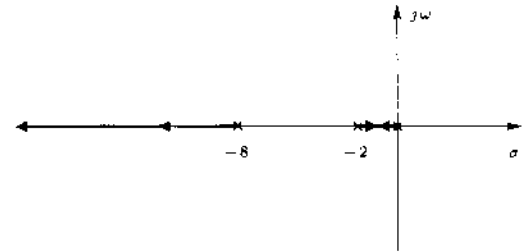

We may also need to determine the imaginary-axis crossings depending on the orientation of the asymptotes.

Asymptotes

Real-Axis Crossing: $\sigma_a = \frac{\sum p_i - \sum z_i}{n - m}$

The real-axis crossing of the asymptotes is at

$$\sigma_a = \frac{\sum_i p_i - \sum_i z_i}{n - m} = \frac{((0) + (-2) + (-8))}{3 - 0} = \frac{-10}{3} = -3.33.$$

Real-Axis Angles: $\theta_a = \frac{\pm(2k+1)\pi}{n - m}$

The angles that the asymptotes make with the real axis are determined from

$$\theta_a = \frac{\pm(2k+1)\pi}{n - m} = \frac{\pm(2k+1)\pi}{3 - 0} = \pm \frac{\pi}{3} \cdot \pi.$$

Breakaway Point: $\frac{dK}{ds} = 0$

From the characteristic equation,

$$1 + G'(s)H'(s) = 0,$$

$$1 + K \frac{1}{s(s+2)(s+8)} = 0,$$

and

$$-K = s^3 + 10s^2 + 16s.$$

Note that this is the same equation for the original system as well. Therefore,

$$-\frac{dK}{ds} = 3s^2 + 20s + 16.$$

and for $dK/ds = 0$, the equation

$$3s^2 + 20s + 16 = 0$$

gives

$$s = -5.74, -0.93.$$

The break-away point is the solution between -2 and 0 that is $s = -0.93$.

However from the asymptote angles, we realize that there will be imaginary-axis crossings. so we need to determine the crossings as well.

Imaginary-Axis Crossings: Routh-Hurwitz Table

The imaginary axis crossings can be determined from the Routh-Hurwitz table. We have determined the characteristic equation above as

$$s^3 + 10s^2 + 16s + K = 0.$$

The Routh-Hurwitz table for this characteristic equation is given below.

s^3	1	16
s^2	10	K
s	$-\frac{(1)(K) - (10)(16)}{10}$	
1	K	

The imaginary-axis crossings will correspond to the values of K that would make a row of all zeros on the table. The two such candidates are the s -row and the 1-row.

- **s-row**

The s -row is all zero, when

$$-\frac{(1)(K) - (10)(16)}{10} = 0,$$

or when $K = 160$. For this value of K , we get a factor of the characteristic polynomial from the upper or the s^2 -row. So,

$$(10s^2 + K)_{K=160} = 0,$$

or $s = \pm j4$. Since the factor leads to a pair of pure imaginary poles for $K = 160$, there will be an imaginary-axis intersection at $s = \pm j4$.

- **1-row**

The 1-row is all zero for $K = 0$. and it corresponds to the open-loop pole at $s = 0$.

With the features determined, we can now sketch the root-locus diagram.

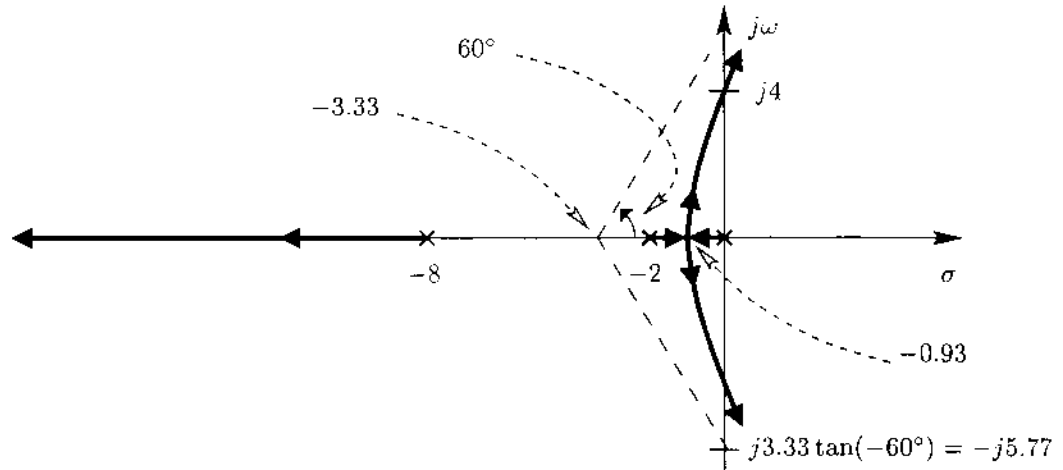

3. For the following feedback control system, design a PID controller; so that the steady state error for a step input is zero; and such that the maximum percent overshoot is less than 5%, and the 2% settling time is less than 0.5 second.

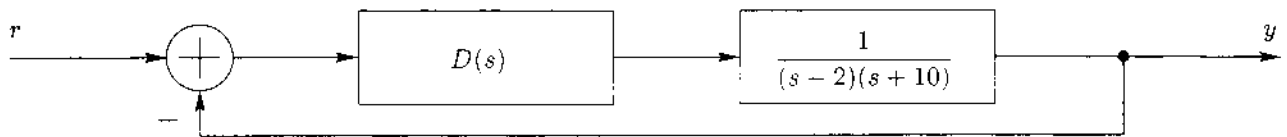

Solution: A PID controller is in the form

$$\begin{aligned}
 D(s) &= K_P + \frac{K_I}{s} + K_D s = \frac{K_D s^2 + K_P s + K_I}{s} \\
 &= K_D \frac{s^2 + (K_P/K_D)s + (K_I/K_D)}{s} \\
 &= K_D \frac{(s - z_1)(s - z_2)}{s}
 \end{aligned}$$

where $-(z_1 + z_2) = K_P/K_D$, and $z_1 z_2 = K_I/K_D$. In other words, the PID controller supplies two zeros at arbitrary locations and a pole at the origin. The performance requirements are listed below, where

$$G(s) = \frac{1}{(s - 2)(s + 10)}$$

Given Requirements	General System Restrictions	Specific System Restrictions
The steady state error is zero for a step input.	$G(s)D(s)$ has a pole at 0.	The PID controller already has a pole at 0.
The maximum percent overshoot is less than 5%.	$e^{-\left(\zeta/\sqrt{1-\zeta^2}\right)\pi} < M_{p_{\text{given}}}$ or $\zeta > \frac{ \ln(M_{p_{\text{given}}}) }{\sqrt{(\ln(M_{p_{\text{given}}}))^2 + (\pi)^2}}$	$\zeta > 0.69$.
The 2% settling time is less than 0.5 second.	$\frac{4}{\sigma_o} < t_{2\%s_{\text{given}}}$ or $\sigma_o > \frac{4}{t_{2\%s_{\text{given}}}}$	$\sigma_o > 8$.

Therefore the desired region for the poles are described by the conditions: $\zeta > 0.69$ and $\sigma_o > 8$. Graphically, these conditions describe the shaded region below.

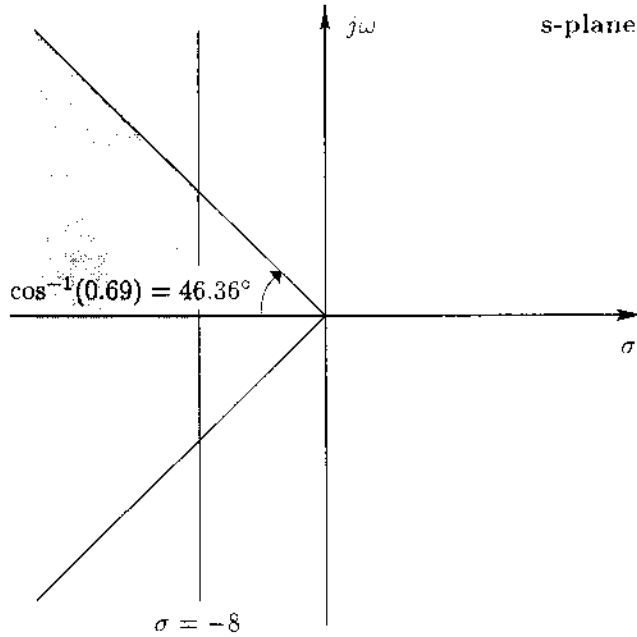

The open-loop system with the PID controller has three poles at -10 , 0 , and 2 , and two zeros yet to be decided. Since we can cancel a stable pole, if we cancel the pole at -10 by using one of the zeros, and place the other zero on the left half-plane; we will end up having two poles and a zero. In this case, the root-locus diagram will contain a circle with center at the zero, and for a small enough zero, we will have the circle crossing into the desired region. Since the radius of the circle is $\sqrt{(z - p_1)(z - p_2)}$ and poles are at 0 and 2 , a choice of a zero smaller than -4 is sufficient. So let

$$D(s) = K_D \frac{(s + 10)(s + 6)}{s}$$

The open-loop gain then becomes

$$D(s)G(s) = K_D \frac{(s + 6)}{s(s - 2)}$$

The root-locus diagram for this open-loop gain as a function of K_D along with the desired region is given below. The radius of the circle is $\sqrt{(-6 - 0)(-6 - 2)} = 4\sqrt{3} = 6.93$.

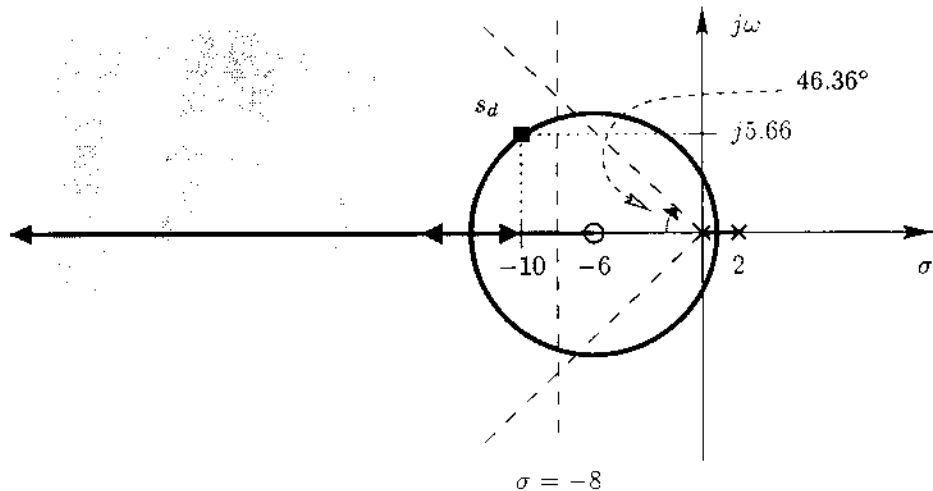

From the root-locus diagram, we can choose a range of desired pole locations. One such choice is to have the real part be -10 . We can determine the imaginary part from the right triangle with vertices at $(-10, 0)$, $(-6, 0)$, and $(-10, \omega)$, or we can just read the value from the graph. In this case, $s_d = -10 + j5.66$. Once the desired location, that is on one of the branches of the root-locus diagram, is determined, we can obtain the root-locus gain from the magnitude condition at the desired location.

$$|D(s)G(s)|_{s=s_d} = 1.$$

$$\left| K_D \frac{(s+6)}{s(s-2)} \right|_{s=-10+j5.66} = 1.$$

or $K_D = 22$. Therefore,

$$D(s) = 22 \frac{(s+10)(s+6)}{s} = \frac{22s^2 + 352s + 1320}{s}.$$

or

$$D(s) = 352 + \frac{1320}{s} + 22s$$

is one possible controller.

4. For the following feedback control system, design the simplest proper controller, such that the 5% settling time is 0.2 second, and the peak time is approximately 0.15 second.

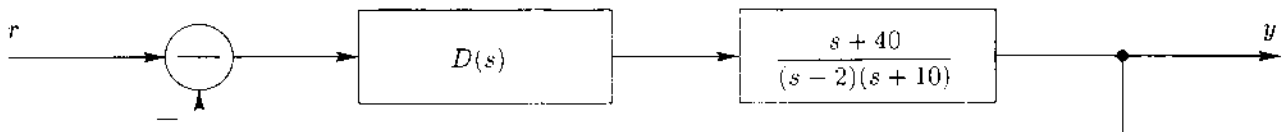

Solution: The performance requirements result in the following restrictions, where

$$G(s) = \frac{s+40}{(s-2)(s+10)}.$$

Given Requirements	General System Restrictions	Specific System Restrictions
The Controller is simplest and proper.	The number of poles and zeros is minimum, and the number of poles is greater than or equal to the number of zeros.	
The 5% settling time is 0.2 second.	For a second order system with no zero, $t_{5\%s} = 3/\sigma_o$.	$\sigma_o = \frac{3}{0.2} = 15.$
The peak time is approximately 0.15 second	For a second order system with no zero, $t_p = \pi/\omega_d$.	$\omega_d = \frac{\pi}{0.15} \approx 21.$

From the above requirements, we need to have the desired poles of the closed-loop system at $s_d = -15 \pm j21$.

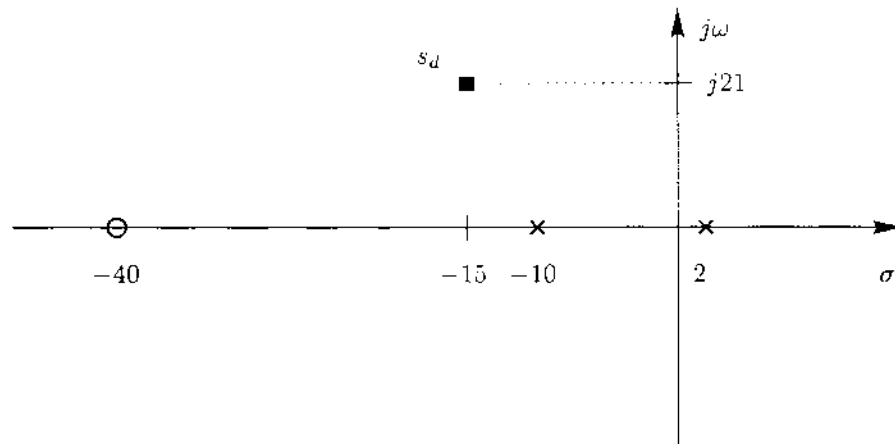

The deficiency angle, ϕ at s_d is calculated from the angular condition.

$$\phi - \angle(s_d - (2)) - \angle(s_d - (-10)) + \angle(s_d - (-40)) = (2k + 1)\pi,$$

$$\begin{aligned} \phi - \tan^{-1} \left(\frac{(21) - (0)}{(-15) - (2)} \right) - \tan^{-1} \left(\frac{(21) - (0)}{(-15) - (-10)} \right) + \tan^{-1} \left(\frac{(21) - (0)}{(-15) - (-40)} \right) \\ = 180^\circ + k360^\circ. \end{aligned}$$

$$\phi - 128.99^\circ - 103.39^\circ + 40.03^\circ = 180^\circ + k360^\circ,$$

or $\phi = 12.35^\circ$.

Since the deficiency angle is positive, we need to design a lead compensator. The only explicit requirement for the lead compensator is that its angular contribution matches the deficiency angle. However, the pole of the compensator may increase the order of the system to three. If we are not careful in the placement of the pole-zero pair, the already approximate values for the settling time and peak time due to the zero of the system will be completely different. We either need to cancel a pole so that the order of the system stays the same, or we need to make sure that the desired locations give the dominant poles of the closed-loop system. The simplest choice is to cancel the stable pole or the pole at $s = -10$ by picking the compensator zero at $s = -10$. We can obtain the location of the compensator pole geometrically.

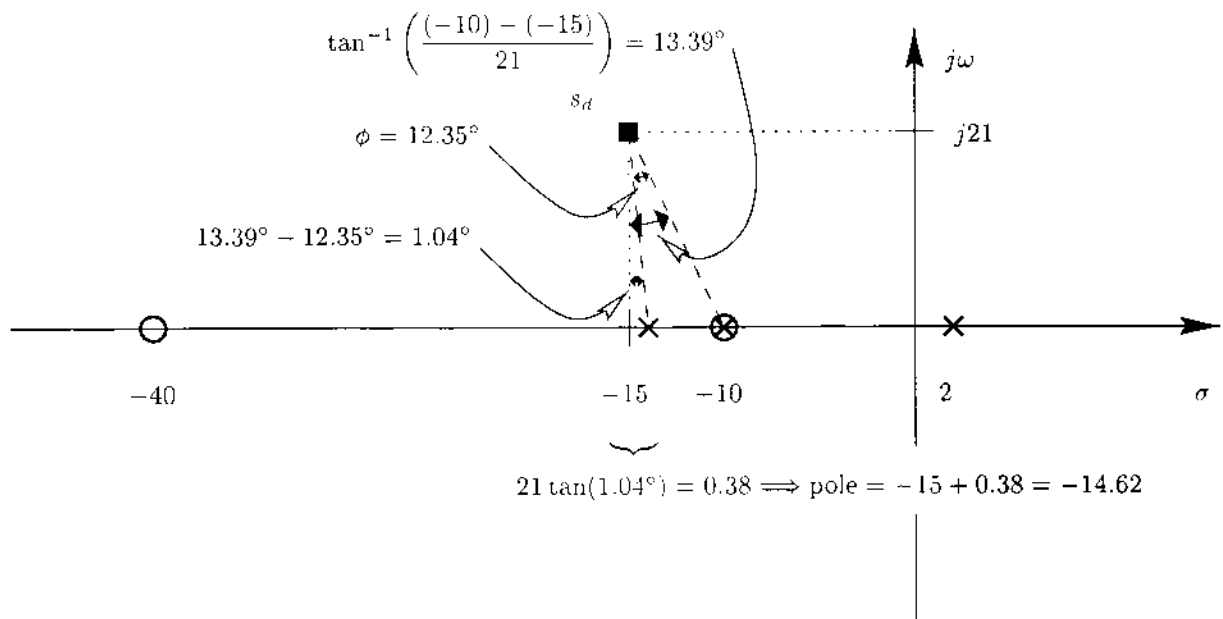

From the above analysis,

$$D(s) = K \frac{s + 10}{s - 14.62}.$$

And the magnitude K is obtained from the magnitude condition at s_d .

$$|D(s)G(s)|_{s=s_d} = 1,$$

$$\left| K \frac{s + 10}{s + 14.62} \cdot \frac{s + 40}{(s - 2)(s + 10)} \right|_{s=-15+j21} = \left| K \frac{s + 40}{(s - 2)(s + 14.62)} \right|_{s=-15+j21} = 1,$$

or $K = 17.38$. Therefore,

$$D(s) = 17.38 \frac{s + 10}{s + 14.62}.$$