

Contour temperature programmed desorption for monitoring multiple chemical reaction products

C. C. Chusuei,^{a)} J. V. de la Peña, and J. A. Schreifels^{b)}

Chemistry Department, George Mason University, Fairfax, Virginia 22030-4444

(Received 27 April 1999; accepted for publication 2 June 1999)

A simple method for obtaining a comprehensive overview of major compounds desorbing from the surface during temperature programmed desorption (TPD) experiments is outlined. Standard commercially available equipment is used to perform the experiment. The method is particularly valuable when high molecular mass compounds are being studied. The acquisition of contour temperature programmed desorption (CTPD) spectra, sampling 50-dalton mass ranges at a time in the thermal desorption experiments, is described and demonstrated for the interaction of benzotriazole adsorbed on a Ni(111) surface. Conventional two-dimensional TPD spectra can be extracted from the CTPD by taking vertical slices of the contour. © 1999 American Institute of Physics. [S0034-6748(99)02609-X]

I. INTRODUCTION

Temperature programmed desorption (TPD) spectroscopy is a widely used technique for detecting different surface chemical environments and surface reaction products, monitoring reaction kinetics involved therein and providing quantitation of adsorbates coverage on the surface. Conventional TPD experiments typically are performed by monitoring a limited number of masses at preselected mass-to-charge (m/e) ratios in a single experiment (typically fewer than 10). Because of this limitation, analysis is limited to the researcher's *a priori* selection of masses to be monitored. Hence, there exists a strong possibility of not detecting important products (especially when monitoring the desorption of complex organic molecules from a surface) in the TPD experiment using this method. A way of scanning wide mass ranges in a TPD experiment would preclude oversights in selecting key m/e ratios due to incomplete understanding of chemical reaction mechanisms on the solid surface.

The limitations of conventional TPD have been recognized and addressed in the literature. Liu and Friend¹ monitored a 100 amu mass range for detecting surface reaction products of cycloheptatriene on the W(100)-(5×1)-C surface by limiting the temperature resolution and accepting a degraded signal-to-noise (S/N) ratio. In their experimental design, a quadrupole mass analyzer (QMA) was set to track the partial pressure for mass numbers rapidly multiplexed from one fixed value to another (some milliseconds between masses) using a digital-to-analog (D/A) channel. The mass resolution of the spectra acquired was limited to one TPD spectrum per dalton. Zagatta *et al.*² scanned a specific range of mass numbers giving a complete mass distribution for that range. This scanning mode of the QMA is typically used for residual gas analysis (RGA) to display mass distribution on an oscilloscope or a two-dimensional (2D) plotter. In doing

so, they were able to rapidly sample gas compounds [from a NO-CO reaction on the Pt(100) surface forming CO₂ and N₂] leaving the surface at a rate of 850 daltons per second using a fast analog-to-digital (A/D) transient recorder.

Both of these methods provide a qualitative survey of temperature programmed reaction products desorbing from the solid surface at a wide mass range. We have combined some aspects of these techniques to our experimental configuration to acquire contour temperature programmed desorption (CTPD) spectra that gives an improved and more complete three-dimensional (3D) picture of reaction products evolving from the surface over the conventional 2D TPD methodology. As with conventional TPD, the pressure rise, ΔP , instead of absolute pressure is measured. This has the effect of reducing (but not totally eliminating) the contribution from background gases. Conventional 2D TPD spectra also can be easily extracted from the CTPD. In our laboratory, we have studied the interaction of *N,N'*-disalicylidene-1,2-propanediamine (MW=282) interacting with 304 stainless steel surfaces using TPD as a primary tool.³⁻⁵ Recording and identifying the intensities of complex mass fragments relevant to the reaction products formed proved to be a challenge and was successfully achieved with the CTPD methodology that we describe below.

II. EXPERIMENT

Figure 1 summarizes the configuration of the control system. TPD experiments were controlled and monitored by an IBM compatible 386 personal computer equipped with Data Translation⁶ DT-2801 data acquisition card (DAC). Wires were connected between the "signal out" and "ramp generator" connections on an UTI-100C⁷ quadrupole mass spectrometer and the input channels on the DAC. Zero and ten volt outputs (0–10 V ramp output is possible) from the "ramp generator" corresponded to the beginning and end of the 50-dalton mass ramp, respectively; the other 0–10 V signal out voltage corresponded to the ion current from the QMS. The heating ramp rate was controlled by an Eurotherm

^{a)}Present address: Chemistry Department, P.O. Box 30012, Texas A&M University, College Station, TX 77842-3012.

^{b)}Author to whom correspondence should be addressed.

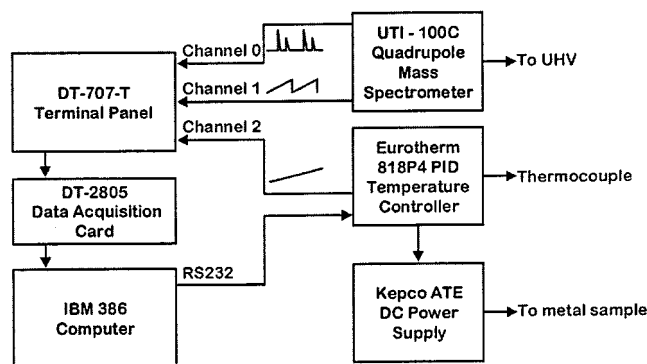

FIG. 1. Block diagram of hardware setup for CTPD. The QMS ion current, thermocouple, and mass ramp voltages are acquired by three respective A/D channels and saved to a single file. Heating is powered by a programmable power supply that receives 0–10 V from the PID controller, which has an independent, internal processor.

Controls⁸ 818P4 proportional integral derivative (PID) temperature controller that is equipped with an independent, internal processor. At the beginning of a TPD experiment, a start command for the experiment typically is sent from the computer via serial port (RS-232) to the PID controller, which then sends out a 0–10 V signal to a Kepco dc power supply to control the linear sample temperature ramp by resistive heating. The sample temperature (read by the PID) was monitored using a chromel-alumel thermocouple that was spot welded to the single crystal. During thermal desorption experiments, A/D signals are sent to the computer via PID controller and DAC card. Thus, ion current from the QMS, temperature and ramp voltage was measured using separate channels of the DAC.

A program was written using Visual Basic Ver. 3.0 and Visual Basic *EZ* from Data Translation to set various parameters, such as the heating rate, starting temperature, the acquisition rate (in Hz), and the number of predetermined data buffers. For a 50-dalton mass range, a total of four 30 000-data-point buffers were used. This gave a total of 40 000 data points for each signal from the QMS ion current, temperature, and mass. These were acquired by multiplexing after sending a ramp start command to the PID. At the end of the experiment data was stored onto a file to later be sorted into a format so that it can be plotted. No attempt was made during the data acquisition phase to sort the different measurements since doing so would result in unacceptable delays. The initial mass, mass range, and scan rate were adjusted using the manual controls on the UTI-100C QMS controller. A typical 50-dalton scan range would take ~ 2.5 s for a single sweep across the mass range, resulting in a resolution of 11 data points per dalton in the CTPD spectrum.

CTPD data was sorted so that a contour plot could be generated using Sigma Plot Ver. 3.0 (a Jandel Scientific, Inc. graphing program). A 3D contour plot is preferred over that of a 3D-mesh plot. In a 3D mesh format, conical structures representing mass spectral peaks can be hidden by others and hence hamper a full overall picture of adsorbates desorbing from the surface. Data was sorted so that there was one column of mass data (x axis), one column of temperature data (y

data), and many columns of ion current (z data). Each column of z data corresponded to one 50-dalton mass scan. The measured ion currents were converted to changes in pressure by subtracting the first scan from the rest. This had the effect of removing most of the intensity from peaks that were part of the residual gas spectrum.

Experiments were carried out in a Perkin–Elmer 4U ESCA chamber. A 300 L/s Thermionics TTSB-200 ion pump provided ultrahigh vacuum (UHV) with a base pressure of $\sim 1 \times 10^{-10}$ Torr after bakeout. The system was equipped with a Perkin–Elmer PHI 15-255GAR double pass cylindrical mirror analyzer for x-ray photoelectron spectroscopy (XPS) and a UTI-100C quadrupole mass spectrometer (QMS) that served as a residual gas analyzer (RGA) and for performing TPD. The QMS was encased in a custom-designed conflat flanged tube so that the opening of the tube can be covered with an electrically isolated Al mesh wire which is biased to -100 V (dc) to deflect stray electrons coming from the QMS. These electrons can otherwise cause unwanted electron beam damage to organic adsorbates on the surface and result in subsequent experimental artifacts in the TPD spectra.

The Ni(111) crystal (Johnson Mathey Chemical Ltd.) was spot welded with 0.010-in.-diam. tungsten wire to a sample holder which is part of a two-level-liquid-nitrogen mounting assembly attached to a Huntington Mechanical Laboratories PM-600 xyz manipulator.⁹ The crystal was initially cleaned by several cycles involving resistively heating to 1100 K for 1 min and cooling to room temperature. Afterwards a single heating and cooling cycle cleaned the crystal. XPS survey scans show no signal from impurities such as carbon or oxygen on the surface verified cleanliness of the crystal. Benzotriazole (BZT; Aldrich Chemical Co.; 99% purity) was used as received after evacuation and extensive outgassing; it was placed in a glass sample vial connected to $\frac{1}{4}$ -in.-diam. stainless steel tubing, which extended into the UHV chamber. This vial was separated from the UHV chamber via a Nupro stainless steel valve, which was left open for the duration of the experiment. The BZT vapor pressure was low, but adequate for dosing without the use of a standard leak valve. The RGA showed no signal for BZT. Adsorption onto the Ni(111) was performed by positioning the crystal approximately $\frac{1}{4}$ of an inch away from the dosing tube for predetermined times. CTPD for these respective exposures were then performed. The system pressure during adsorption and CTPD experiments rose no higher than $\sim 5 \times 10^{-10}$ Torr.

III. RESULTS

Figure 2 shows the resulting CTPD spectrum after a 120 s exposure of BZT. This contour is the combination of three 50-dalton experiments using the same initial temperature and ramp rate. All possible fragments that might be the result of the decomposition of BZT (MW = 119) are monitored with only three experiments, including higher molecular weight compounds that can result from the recombination of BZT fragments. Significant amounts of higher molecular mass compounds were observed in another CTPD study.⁵

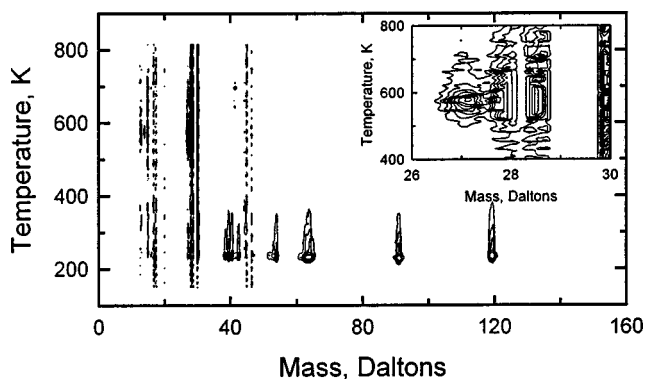

FIG. 2. CTPD spectrum of BZT adsorbed on Ni(111) after a 120 s exposure in UHV. The spectrum is a combination of three separate, identical 50-dalton CTPD runs. The inset contains an expanded region showing rings at 27 daltons arising from a compound derived from the decomposition of BZT.

The topographical rings represent QMS ion current intensities at certain masses and temperatures; the greater the density of the rings, the higher the QMS intensity. The series of intensities at various masses centered at 240 K and about 300 K are due to physisorbed and chemisorbed molecular BZT, respectively, and are derived from the cracking pattern of the parent compound after desorption and ionization in the QMS. Any one of the series of peaks from molecular BZT could be used to study its characteristics on the surface with single mass TPD since their thermal characteristics as a result of surface interaction are all the same. The highest mass where intensity was observed was 119 daltons, denoting the molecular ion of BZT.

Intensities at other desorption temperatures are attributed to desorption of BZT decomposition products on the surface. The most notable product has a m/e ratio of ~ 27 daltons (indicated by a series of rings) desorbing at 600 K. This is barely visible in the composite CTPD spectrum but is easily seen in the inset that is an expansion of this region. The appearance of this intensity is likely due to the formation of HCN when BZT decomposed. It is clearly not part of the BZT cracking pattern since it is not observed at other masses where there are peaks associated with the cracking pattern. The low intensity compared with the higher intensities of some of the BZT peaks at 240 K suggest that the coverage of this substance is relatively low and demonstrates that relatively small coverages of compounds other than the original molecule should be detectable using CTPD. The relatively complete resolution of neighboring peaks also demonstrates that good mass resolution is possible. When studying fairly low coverages however, it might be desirable to reduce the resolution to enhance the S/N ratio. The vertical streaks at 18, 28, and 44 daltons are the result of imperfect subtraction of the relatively large background intensities of H_2O , CO , and CO_2 .

Conventional 2D TPD have been previously extracted by using all of the QMS ion current intensities at a given mass as a function of the temperature.² TPD spectra here are obtained by taking a vertical cross-sectional slice in the contour at a given mass (along the x axis of the plot) from several CTPD spectra of BZT at various exposures. TPD

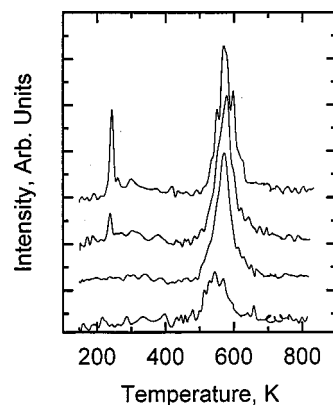

FIG. 3. TPD uptake plot at 27 daltons extracted from CTPD spectra of BZT adsorbed on Ni(111) at various exposures: 20, 60, 120, and 210 s. Physisorbed and chemisorbed states of the decomposition compound are readily seen.

spectra of HCN were thus extracted from each of the CTPD to observe growth characteristics (Fig. 3). Although the S/N ratio is not optimal, it is possible to observe signal from coverages that are less than $\frac{1}{2}$ that of saturation. Recalling that the main surface component is BZT, it appears possible to observe coverages that are much less than $\frac{1}{4}$ of a monolayer. The low temperature peak associated with physisorbed state of BZT is only observed at the higher exposures and thus indicative of it being a weak peak in the cracking pattern of BZT as well as from a reaction fragment. It is also possible from this same set of data to construct uptake curves of any other substance that is observed in the CTPD spectra. For example, the uptake curve for a mass of 40 was extracted from the same data set and is shown in Fig. 4. The S/N ratio is still not optimal, however the growth of the chemisorbed and physisorbed states can readily be seen. Part of the reason for the reduced S/N ratio in these experiments come from the fact that the QMS used in these experiments had a rather old electron multiplier with lower than usual gain. This set of peaks (40 daltons) can be easily distinguished from the set in Fig. 3 (27 daltons), which have a different peak shape and higher desorption temperature. The peak shapes in the 40 and 119 dalton (in the inset) uptake plots have the same shape, which denotes their common origin from molecular

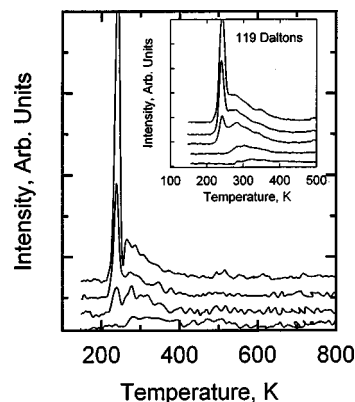

FIG. 4. TPD uptake plot at 40 daltons extracted from CTPD spectra of BZT adsorbed on Ni(111) at various exposures: 20, 60, 120, and 210 s. The inset is a TPD uptake plot (also extracted from CTPD spectra) at 119 daltons, the BZT parent ion. The ion current at 119 daltons is higher than at 40 daltons.

BZT (showing internal consistency) and demonstrates the reliability of 2D TPD data that can be extracted from the CTPD plots.

IV. DISCUSSION

The feasibility of obtaining from a small number of CTPD experiments an analysis of all major substances desorbing from a surface has been demonstrated. This was accomplished by continuously monitoring the pressure change of a relatively large mass range during a temperature ramp. A conventional TPD spectrum of any mass scanned in the CTPD spectrum is readily available. Acquisition of CTPD spectra at various coverages makes it possible to monitor the growth characteristics of the whole mass range scanned (50 daltons) simultaneously suggesting that CTPD could replace conventional TPD with no loss in terms of the quality of the information obtained. Modification of the Visual Basic pro-

gram is under way to enable extraction of individual 2D TPD spectra via scrolling through vertical slices of the mass range of the CTPD spectrum immediately after the experiment.

¹A. C. Liu and C. M. Friend, *Rev. Sci. Instrum.* **57**, 1519 (1986).

²G. Zagatta, H. Müller, N. Böwering, and U. Heinzmann, *Rev. Sci. Instrum.* **65**, 359 (1994).

³C. C. Chusuei, Ph.D. Dissertation, George Mason University, Fairfax, VA, 1997.

⁴C. C. Chusuei, R. E. Morris, and J. A. Schreifels, *Ind. Eng. Chem. Res.* **37**, 3610 (1998).

⁵C. C. Chusuei, R. E. Morris, and J. A. Schreifels, *Appl. Surf. Sci.* (submitted).

⁶Data Translation, Inc., 100 Locke Dr., Marlboro, MA 01752-1192.

⁷MKS Instruments, Inc., Six Shattuck Rd., Andover, MA 01810-2449.

⁸Eurotherm Controls, Inc., 11485 Sunset Hills Rd., Reston, VA 22090-5286.

⁹C. C. Chusuei, L. K. Gwynn, and J. A. Schreifels, *Rev. Sci. Instrum.* **63**, 3218 (1992).