

# Nonlinear Modified PI Control of Multi-Module GCSCs in a Large Power System

Swakshar Ray, *Student Member, IEEE* and Ganesh K. Venayagamoorthy, *Senior Member, IEEE*

Real-Time Power and Intelligent Systems Laboratory  
Department of Electrical and Computer Engineering  
University of Missouri- Rolla, MO 65409-0249 USA  
[sr8r8@umr.edu](mailto:sr8r8@umr.edu) and [gkumar@ieee.org](mailto:gkumar@ieee.org)

**Abstract**— This paper presents the design of a new control strategy for Gate-Controlled Series Compensators (GCSCs). GCSCs are new FACTS devices which can provide active power flow control on a transmission line. Proper placement of GCSCs in proximity to generators can also provide damping to system oscillations. This paper has investigated the effectiveness of multiple Multi-Module Gate Controlled Series Compensators (MMGCSCs) for large power systems. MMGCSCs can be less expensive devices with wide range of control of capacitive reactance in series with transmission lines. A Nonlinear Modified PI (NMPI) control is developed to provide power flow control and enhanced transient stability margin of the multi-machine power system. The NMPI is designed using a multi-layer neural network to approximate the blocking angle from the effective capacitive compensation provided by PI controller. A neural network with few neurons trained offline is used as an approximator /estimator for each MMGCSCs. This method has been shown effective for small and large disturbances on the IEEE 39 bus power system.

**Keywords**— gate controlled series compensator; IEEE 39 bus system, NMPI; neural networks; power system stability.

## I. INTRODUCTION

In the recent days, it is becoming increasingly difficult to build new transmission lines due to restrictions imposed by financial and environmental issues. As the energy consumption is increasing, the existing transmission lines have to be operated more efficiently and close to their stability limits in the future. The FACTS (Flexible AC Transmission Systems) devices have introduced the concept of controlling the real and/or reactive power flow in a transmission line. Proper routing of power not only increases sustainability of growing demand, but also provides better stability to the system. The series line reactance is one of the main factors which govern the maximum power flow through a transmission line. The usual technique for real power control is to use fixed capacitors in series with the transmission line to reduce the effective inductive reactance of the line. But, fixed capacitors do not provide options for controlling the power flow according to the requirements which may vary at different times. This problem is overcome by series FACTS devices like Thyristor Controlled Series Compensator (TCSC) [1-2] and Gate-Controlled Series Compensator (GCSC) [3-5]. There is another series compensator – Static Synchronous Series Compensator (SSSC) [6], but it is a Voltage Source Inverter (VSI) based

device which is more versatile and expensive. With GCSCs, the effective capacitive reactance of the compensator can be varied dynamically to control the real power flow in a line over a certain range. Thus, it not only provides power flow control over different steady-state operating zones but can also enhance transient stability of the system during sudden disturbances. The operation of single module GCSCs have been reported by Watanabe [3-5].

A simple GCSC device is composed of one capacitive reactance and two anti-parallel GTOs in parallel with the capacitor in each phase. The problem with single module GCSC is that it is difficult to control the blocking angle for small reactances. One way to solve this problem is to use an architecture consisting of multiple modules of GCSCs in parallel. The major advantages in this architecture lie in the current sharing capability between GTOs and capacitors connected in parallel and the smaller sizing of the capacitances. Smaller capacitance value for each module provides better control range and redundancy in the path of power flow. This multi-module GCSC (MMGCSC) structure provides all the advantages of single module GCSC while providing better controllability of the blocking angle. Several GCSC modules can be connected in parallel and controlled with the same GTO signal simultaneously.

Due to the nonlinear relationship between the power flow in the line, effective capacitive reactance and blocking angle, the performance of a linear PI control degrades for large changes in operating conditions. Advanced neural network based control has been proven effective for single module GCSCs but this requires intense design and higher computational cost [9]. To further enhance the control capability of the MMGCSCs, a Nonlinear Modified PI (NMPI) controller is designed to control the blocking angle for the GTOs. Neural networks are universal function approximators [7-8]. In this design, a neural network (NN) estimates the blocking angle from the compensation reactance provided by a linear PI controller.

The combination of MMGCSC and NMPI provides better control capability with less complexity. This combination is studied on the IEEE 39 bus New England power system [10] in multiple locations simultaneously. The rest of the paper is outlined as follows. In section II, the MMGCSC structure is described. The multi-machine power system is discussed in section III. Section IV presents the NMPI method for the control of MMGCSC. Section V

The support from the National Science Foundation under the NSF CAREER Grant No: ECS # 0348221 and NSF Grant ECS # 0524183 are gratefully acknowledged by the authors.

presents results showing the advantages of the MMGCSC architecture and NMPI control methodology. Finally conclusions are given in section VI.

## II. MULTI-MODULE GATE-CONTROLLED SERIES CAPACITOR

Each GTO-controlled series capacitor module is composed of two anti-parallel GTOs and a capacitor bank in series with the transmission line for each phase. If the GTOs are turned on all the time then the capacitor is by-passed and it does not provide any compensation. However, if the GTO's are turned off once per cycle at a determined blocking angle of  $\alpha$ , the capacitor in series with the transmission line turns on and off alternately and the effective capacitance of the device can be varied. The GCSC has a great advantage because the blocking angle  $\alpha$  can be varied continuously to provide variable capacitance and there is no problem of parallel resonance unlike in TCSC [1]. In the GCSC, a blocking angle of 90 degree means that the capacitor is fully inserted and a blocking angle of 180 degree means that the capacitor is fully by-passed.

In [5], the authors have illustrated use of several series modules to form a MMGCSC. But, for practical control purposes, the series combination of these modules is not feasible since each module controls a very small reactance. In addition, the size of each capacitor is larger, making it a more expensive technology. To improve the control capability, a multi-module architecture with single module GCSCs in parallel as shown in Fig. 1 is advantageous.

Fig. 2 shows the nonlinear relationship between the blocking angle ( $\alpha$ ) and the effective capacitive reactance ( $X_{eff}$ ) across each GTO pairs as given in (1). For smaller capacitances (larger reactance), more precise control can be achieved easily.

$$X_{eff} = \frac{X_c}{\pi} [2\alpha - 2\pi - \sin 2\alpha] \tag{1}$$

Where,  $X_c$  is the total installed reactance of the capacitor bank.

The MMGCSC architecture provides a wider range of reactance to be controlled by each GTO pair while maintaining the required effective capacitive reactance in series with the transmission line. The blocking angle is generated from a single controller and can be provided to all the GTOs in parallel through a synchronized optical fiber link. Some additional advantages of the MMGCSC:

- small current rating for the GTOs providing cost effective solution for large systems with multiple GCSCs;
- smaller capacitor sizes
- the redundant structure provides better reliability.

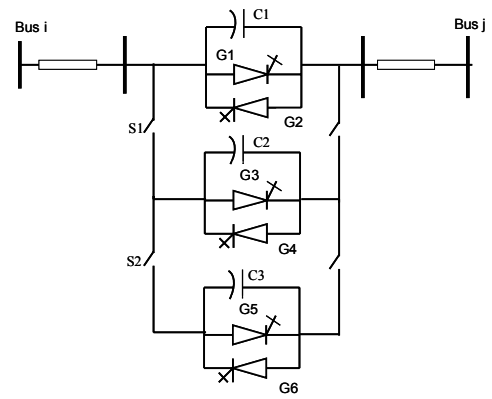

Figure 1. Multi-module GCSC inserted in a transmission line.

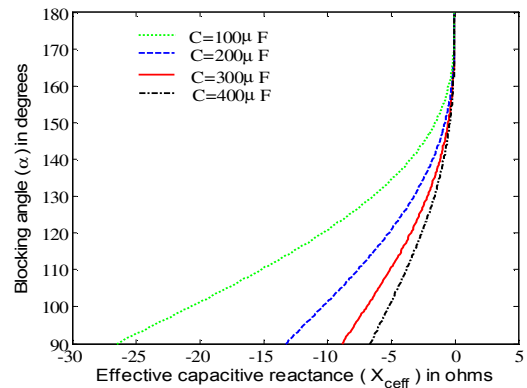

Figure 2. Blocking angle vs. Effective capacitive reactance.

## III. MULTI-MACHINE POWER SYSTEM

The combination of MMGCSC and NMPI control has been applied on the IEEE 39 bus New England power system in two locations (Fig. 3). The IEEE 39 bus New England system [10] is considered to be one of the critical benchmark systems for transient and steady-state analysis. The 39 bus system has 9 generators and one infinite bus connected to several loads (Total  $P_L=6150.50$  and total  $Q_L=1408.9$  MVar) through 34 of 345 KV high voltage transmission lines. The selected system exhibits several modes of oscillations in the generator speed during impulsive disturbances. The main objective here is to show that the multiple MMGCSCs can control active power through transmission lines as well as provide damping to the nearby generators.

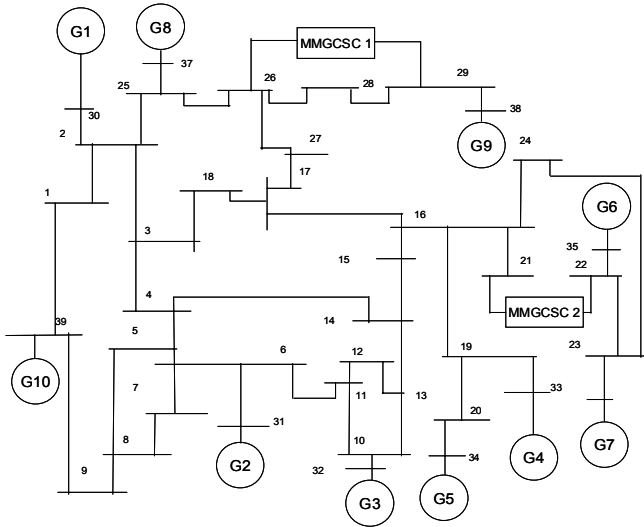

Figure 3. IEEE 39 bus system with two multi-module GCSCs.

#### IV. NONLINEAR MODIFIED PI CONTROL (NMPI)

Due to the wide saturation region in the relation of capacitive compensation reactance and the blocking angle (Fig. 4), the PI controller providing blocking angle directly have difficulty to adjust in the saturation region. There are a few ways to overcome this problem. A look-up table is one of them. But for a look-up table, the accuracy depends on the number of points considered, and more number of points increases the online computational effort exponentially. The other option is to use a function approximator. In this paper, the latter option is selected and a neural network is trained offline using PSO [11] to approximate the relationship in (1) i.e. to predict the blocking angle from the effective capacitive compensation provided by a PI controller. In this study, two MMGCSCs have been chosen to be located in line 26-29 and 21-22 due to their proximity to generators G9 and G6 respectively (Fig. 3). Both the MMGCSCs control power flow in line 26-29 and 21-22 respectively. In addition, due to their proximity to generators G9 and G6, proper control can provide damping to the speed oscillations of the generators.

A small neural network with fixed weights is used with 1 input linear neuron, 4 sigmoidal neurons in the hidden layer and one output linear neuron (Fig. 4) for the control of MMGCSC 1. Another fixed weight neural network with 1 input linear neuron, 3 sigmoidal neurons in the hidden layer and one output linear neuron is used for the MMGCSC 2. These neural networks are trained offline to predict the blocking angle from the effective capacitive reactance provided by the PI controller. The general equations of a MLP neural network with one hidden layer having sigmoidal transfer function is given by (2),

$$y = V \cdot d \quad (2)$$

$$\text{where } d = \frac{1}{1 + e^{-W \cdot X}} \quad (3)$$

and  $X = [X_{\text{ceff}}, 1]^T$  is the input vector,  $y$  is the output blocking angle ( $\alpha$ ),  $W$  is the input weight matrix and  $V$  is the output weight matrix. More details on the neural network

approximators can be found in [7-8]. The stabilizing fixed weights are given in the appendix.

After training, the neural networks are connected in conjunction with the respective PI controllers for each MMGCSCs. In the controller block diagram (Fig. 5), when switch  $S$  is in position 1, the output of the PI controller subtracted from  $180^\circ$  ( $\alpha$ ) is fed to the firing circuit according to the typical GCSC control scheme and when  $S$  is in position 2, the output of the approximator ( $\alpha$ ) is fed to the GCSC firing circuit directly (the proposed NMPI control scheme). This proposed NN design incorporates nonlinearity in a traditional linear controller.

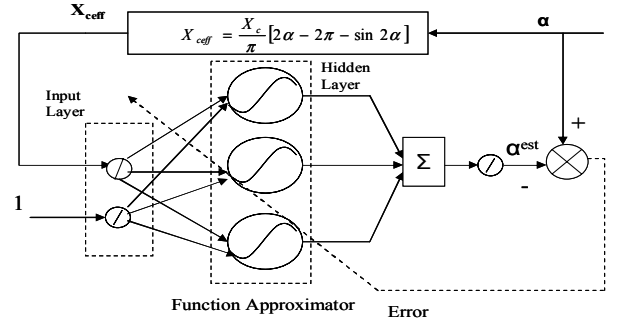

Figure 4. Training of the function approximator to estimate the blocking angle.

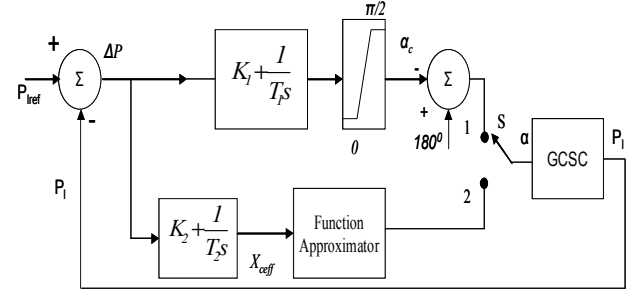

Figure 5. The control block diagram of the GCSC with PI and PI-MLP controller.

#### V. IMPLEMENTATION RESULTS

Multiple MMGCSCs with the presented NMPI control method are evaluated on the IEEE 39 bus power system in the PSCAD/EMTDC environment. The results of two neural network approximators for two MMGCSCs are presented in section V-A. The damping effect of the presented control strategy on the active power flow and on the nearby generator speeds is illustrated in section V-B. The advantages of placement of multiple MMGCSCs are illustrated through various simulations.

##### A. Neural Network Approximator

After the offline training of the MLP-neural networks as approximators, the weights of the neural networks are frozen. The fixed weight neural networks are used for generating appropriate blocking angles for MMGCSC 1 and 2. Fig. 6

shows the blocking angle of the approximator used for MMGCSC 1 located on line 26-29 (Fig. 3) in proximity to generator G9. Three capacitor modules are connected in parallel on each phases of line 26-29 having a capacitance of 17  $\mu$ F. Hence, each module can provide a capacitive compensation equals to a maximum of -156 ohms. The capacitive compensation vs. estimated blocking angle (shown by the solid line) is compared with the required blocking angle (dashed line). The dotted line shows the relationship of blocking angle and effective capacitive compensation for the complete MMGCSC 1. Thus, the multi-module architecture provides the flexibility of operating in a wider linear region of capacitive compensation vs. blocking angle curve, compared to a single GCSC of equivalent capacitance given by dotted curve, with steep and highly saturated region of operation.

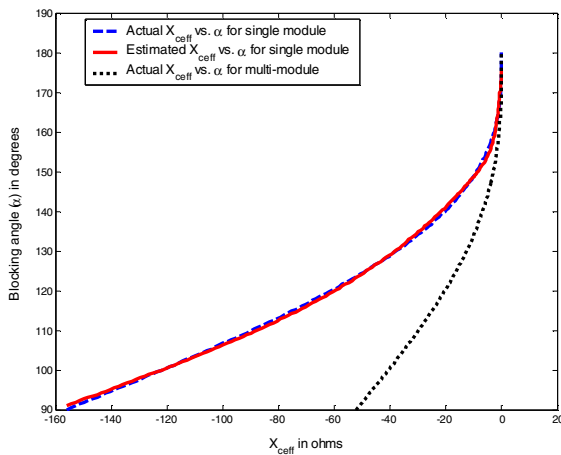

Figure 6. Relation between the effective capacitive reactance and blocking angle predicted by a MLP approximator for GCSC 1.

Capacitance of each module per phase for MMGCSC 2 is 110  $\mu$ F. Three parallel modules per phase have been used. The maximum reactive compensation provided by each module is -24 ohms. The required (dashed line) and predicted (solid line) blocking angle corresponding to the complete range of compensation is shown in Fig. 7. Both estimators exhibit accurate approximation of the blocking angle with only 3-4 hidden sigmoid neurons. The dotted line shows the relationship of blocking angle and effective capacitive compensation for the complete MMGCSC 2.

### B. NMPI Controllers on Multiple MMGCSCs

In large power systems, disturbances cause oscillations in both power flow in transmission lines and rotor angle in generators. The main purpose of the new series FACTS device- GCSC is to provide active power flow control through transmission lines by changing the effective series reactance dynamically. In addition, GCSCs can be damping control devices. In this section, some of the simulation results are presented to show the effectiveness of the NMPI for generating the blocking angles and the influence of

proper placements of multiple GCSCs on system stability and damping.

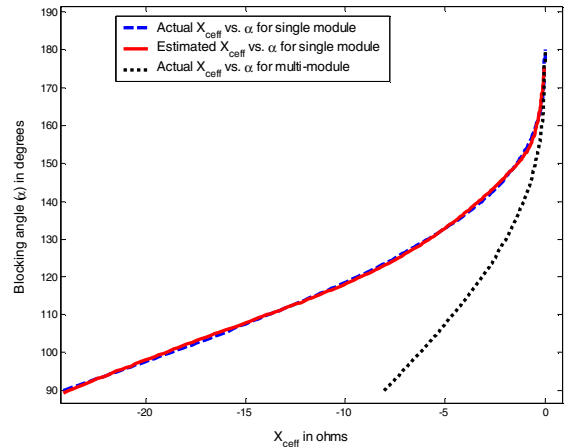

Figure 7. Relation between the effective capacitive reactance and blocking angle predicted by a MLP approximator for GCSC 2.

Fig. 8 illustrates the power flow capability of the MMGCSC. A 25% step change in active power on line 26-29 is commanded using the PI and the NMPI controllers. Both the controllers are tuned such that they show similar acceptable steady-state performance.

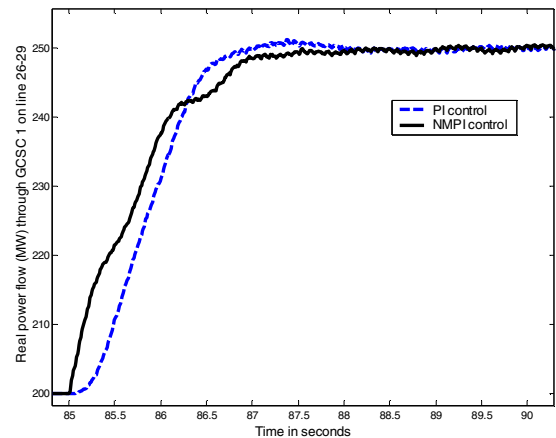

Figure 8. 25% step change in power with MMGCSC 1.

In the second phase of simulation results (Figs. 9 – 12), the implications of multiple MMGCSCs in providing additional damping to the generators in proximity has been investigated. These tests are performed with power flows of 250 MW and 630 MW through MMGCSC 1 and MMGCSC 2 respectively. Figs. 9 and 10 show the effect of one and two MMGCSCs in providing damping torque to the oscillating generators due to a 200ms 3- $\Phi$  fault at bus 17 (Fig. 3) which is cleared by opening the breakers on lines 17-18, 17-27 and 16-17 simultaneously. The breakers are reclosed after 0.8 second delay. It can be seen that the generator close to the

MMGCSCs experience additional damping. Though generators G9 and G6 are very much electrically apart from each other, the MMGCSCs located in neighborhood of one generator has some effect on the other generator. This shows that appropriate placements of multiple MMGCSCs can provide better damping to different generators.

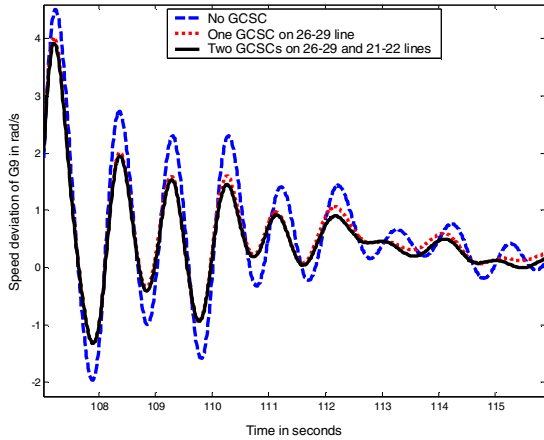

Figure 9. Speed deviation of generator G9 for due to a 200 ms 3- $\Phi$  fault at bus 17 (Fig. 3).

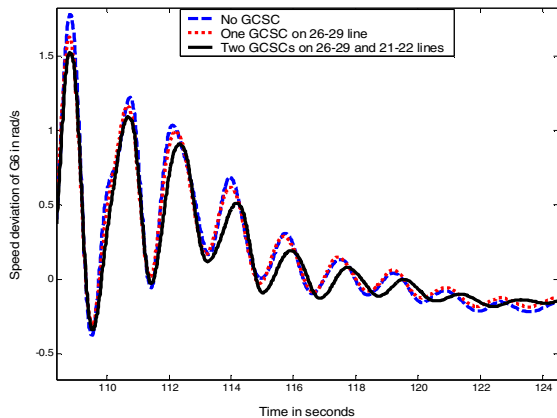

Figure 10. Speed deviation of generator G6 for due to a 200 ms3- $\Phi$  fault at bus 17 (Fig. 3).

Figs. 11 and 12 show similar results for a (n-2) contingency due to line outages of lines 25-26 and 17-18 simultaneously for 1.0 seconds. The damping provided by both the MMGCSCs is evident to the nearby generators. Generators G9 and G6 show improved performance with the nearby MMGCSCs turned on.

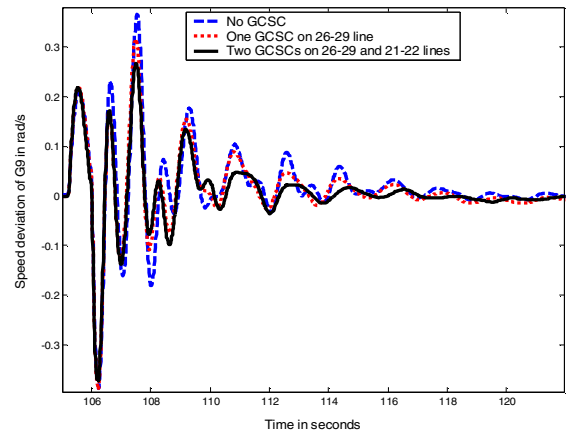

Figure 11. Speed oscillations in generator G9 due to outage of lines 25-26 and 17-18 for 1 sec. during a (n-2) contingency.

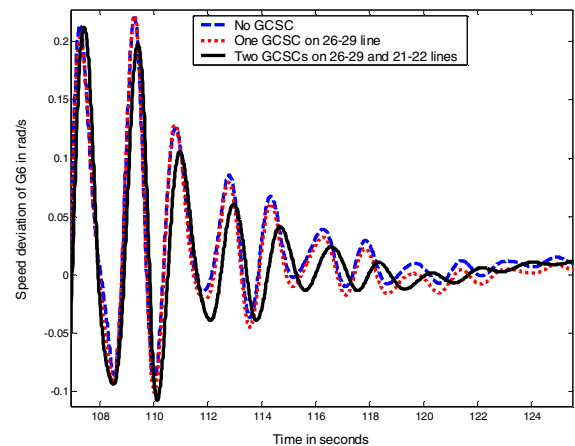

Figure 12. Speed oscillations in generator G6 due to outage of lines 25-26 and 17-18 for 1 sec. during a (n-2) contingency.

Further investigations have substantiated the improved performance of the NMPI control method over the linear PI control. In Figs. 13 and 14 show the line flows in line 26 -29 and 21 – 22 respectively for a 200ms 3- $\Phi$  fault at bus 17 (Fig. 3) which is cleared by opening the breakers on lines 17-18, 17-27 and 16-17 simultaneously. The breakers are reclosed after 0.8 second delay. The NMPI controller performance is better than its linear counterpart. In Fig. 15, a (n-2) contingency has been simulated by opening the breakers on line 25-26 and 17-18 for 1 second; the NMPI controller exhibit better performance in stabilizing the active power flow through line 26-29 than its counterpart. It has been observed that the NMPI performs better than the linear PI controller when the commanded power flow through the MMGCSCs forces the blocking angles close to their extreme limits of 90<sup>0</sup> and 180<sup>0</sup>. Fig. 16 shows the comparative performances of speed oscillations of generator G9 with two MMGCSCs on line 26-29 and line 21-22 (solid

line) using NMPI controller and with two MMGCSCs using linear PI controller (dashed line). Two GCSCs with NMPI controllers show the best performance over wide operating regions and variety of disturbances.

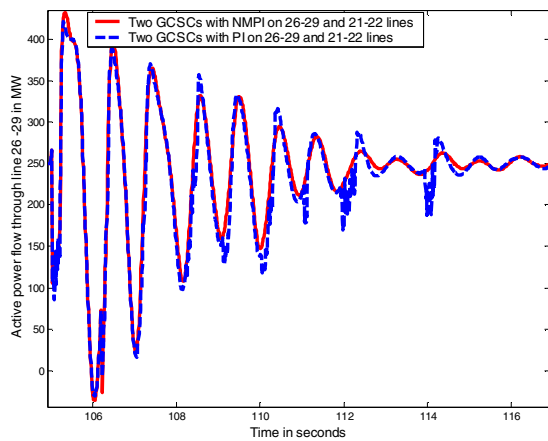

Figure 13. Active power flow through line 26-29 due to a 200 ms 3- $\Phi$  fault at bus 17.

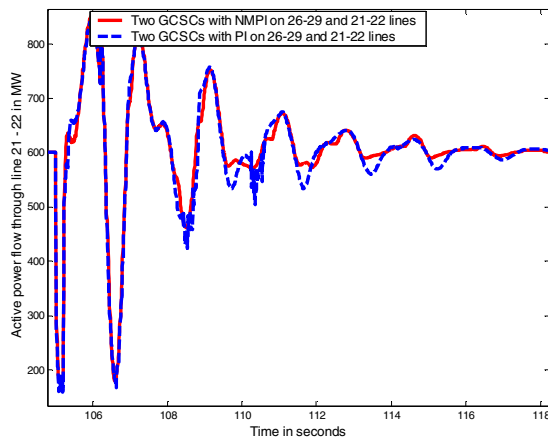

Figure 14. Active power flow through line 21-22 due to a 200 ms 3- $\Phi$  fault at bus 17.

## VI. CONCLUSION

The paper has presented a new architecture of multi-module GCSCs in parallel to provide cost effective solution to series compensation for large power systems. A new nonlinear approximation based PI control has been designed to provide better performance throughout the region of operation. Investigation has also shown improvement in both power flow and damping generator speed oscillations during disturbances with MMGCSCs in proximity to generating stations. In the presented NMPI control strategy, small neural networks are used to estimate blocking angles from the required capacitive compensation provided by linear PI

controllers during both steady-state and transient operations. The design and development of the presented architecture has been implemented on the IEEE 39 bus power system. The simulation results show accurate control of power flow using the MMGCSCs and improved system damping with the nonlinear modified PI control method.

The GCSC being a relatively inexpensive and simpler power flow control device has a lot of potential to be introduced in locations where fixed capacitors or other series FACTS devices are currently used. For higher power transfer through high impedance lines, MMGCSC provide a cost effective feasible solution. Thus, the presented architecture and control method having lower current carrying requirement for the gate controlled switches show future promises as series compensation devices. This architecture also allows the existing fixed capacitors to be retrofitted with gate-controlled switches for operating as FACTS devices.

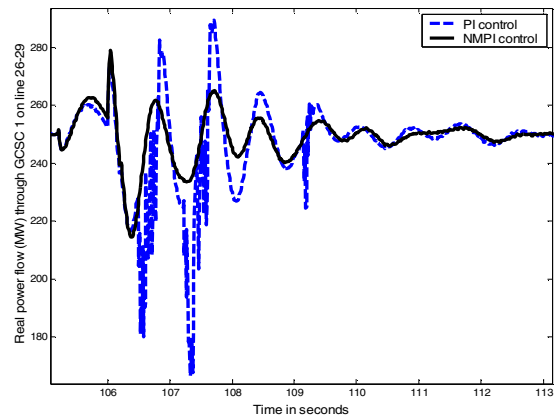

Figure 15. Power flow oscillations in line 26-29 due to outage of lines 25-26 and 17-18 for 1 sec. during a (n-2) contingency.

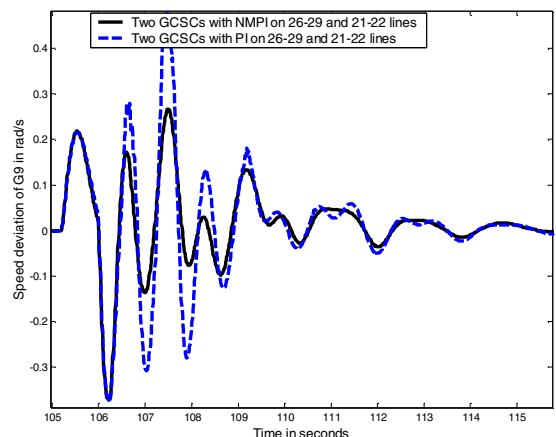

Figure 16. Speed oscillations in generator G9 due to outage of lines 25-26 and 17-18 for 1 sec. during a (n-2) contingency.

## REFERENCES

- [1] C. Gama, "Brazilian north-south interconnection control-application and operating experience with a TCSC", IEEE Power Engineering Society Summer Meeting, vol. 2, pp. 1103 – 1108, July 1999.
- [2] J. F. Hauer, W. A. Mittelstadt, R. J. Piwko, B. L. Damsky and J. D. Eden, "Modulation and SSR tests performed on the BPA 500 kV thyristor controlled series capacitor unit at Slatt substation", IEEE Transactions on Power Systems, vol. 11, issue 2, pp. 801-806, May 1996.
- [3] L. F. W. de Souza, E. H. Watanabe, M. Aredes, "GTO controlled series capacitor", in Proc. IEEE Power Engineering Society winter meeting., vol. 4, pp. 2520-2525, Jan. 2000.
- [4] L. F. W. de Souza, E. H. Watanabe, J. E. R. Alves, L. A. S. Pilotto, "Thyristor and gate controlled series capacitors: comparison of components rating", in Proc of IEEE Power Engineering Society General Meeting, vol. 4, pp: 2547, July 2003.
- [5] L. F. W. de Souza, E. H. Watanabe, M. Aredes, "GTO controlled series capacitors: multi-module and multi-pulse arrangements", IEEE Transactions on Power Delivery, vol. 15 , no. 2 , pp. 725 – 731, Apr. 2000.
- [6] F. A. L. Jowder, "Influence of mode of operation of the SSSC on the small disturbance and transient stability of a radial power system", IEEE Transactions on Power System, vol. 20, Issue 2, pp. 935 – 942, May 2005.
- [7] F. Girosi; T. Poggio, "Neural networks and best approximation property," Biolog Cybernetics, vol. 63, pp. 169-176, 1990.
- [8] K. S. Narendra, K. Parthasarathy, "Identification and control of dynamical systems using neural networks," IEEE Transactions on Neural Networks, vol. 1, pp. 4-27, Mar. 1990.
- [9] S. Ray, G. K. Venayagamoorthy, E. H. Watanabe, F. D. de Jesus, "Optimal dynamic neurocontrol of a gate-controlled series capacitor in a multi-machine power system," Proceedings of the 13<sup>th</sup> International Conference on Intelligent Systems Application to Power Systems, pp. 221 – 227, 6-10 Nov. 2005.
- [10] M. A. Pai, Energy function analysis for power system stability, Boston, US, Kluwer Academic Publishers, 1989.
- [11] V. G. Gudise, G. K. Venayagamoorthy, "Comparison of particle swarm optimization and backpropagation as training algorithms for neural networks," Proceedings of the IEEE Swarm Intelligence Symposium, pp. 110 – 117, 24 – 26 Apr. 2003.

## APPENDIX

The weights of the neural networks for MMGCSC 1 and MMGCSC 2 are respectively:

$$W_1 = \begin{bmatrix} -2.5161 & 2.2137 \\ 0.3666 & 1.8143 \\ -2.4038 & 2.0620 \\ 62.6131 & -1.3087 \end{bmatrix} V_1 = [-4.1049 \quad 8.4275 \quad -3.4328 \quad 1.8648]$$

$$W_2 = \begin{bmatrix} 81.7677 & -2.8625 \\ -1.7465 & -2.3712 \\ 6.0773 & -0.3798 \end{bmatrix} V_2 = [7.4316 \quad -2.8939 \quad 1.8299].$$