

Neural Network based Decentralized Excitation Control of Large Scale Power Systems

Wenxin Liu¹, *Member, IEEE*, Jagannathan Sarangapani², *Senior Member, IEEE*,
Ganesh K. Venayagamoorthy², *Senior Member, IEEE*, Donald C. Wunsch II², *Fellow, IEEE*,
and David A. Cartes¹, *Member, IEEE*

Abstract—This paper presents a neural network (NN) based decentralized excitation controller design for large scale power systems. The proposed controller design considers not only the dynamics of generators but also the algebraic constraints of the power flow equations. The control signals are calculated using only local signals. The transient stability and the coordination of the subsystem controllers can be guaranteed. NNs are used to approximate the unknown/imprecise dynamics of the local power system and the interconnections. All signals in the closed loop system are guaranteed to be uniformly ultimately bounded (UUB). Simulation results with a 3-machine power system demonstrate the effectiveness of the proposed controller design.

Index Terms—Decentralized control, power system control, neural networks, and large scale system.

I. INTRODUCTION

POWER systems are large scale, distributed and highly nonlinear systems with fast transients. To coordinate the control activities of the overall system, centralized control schemes are proposed by assuming that global information of the overall system is available. However, centralized controllers are very difficult to design and implement for complex large scale systems due to technical and economic reasons. Further, centralized controller designs are dependent upon the system structure and cannot handle the structural changes.

Decentralized control schemes are proposed to overcome the problems of centralized control. Instead of designing a global central controller, decentralized control design aims at designing separate local controller for each subsystem. The subsystem controllers require only local signals and/or a minimum amount of information from other subsystems.

The traditional decentralized control strategies of power systems were designed based on linearized system models at certain operating points. The selection of operating points and tuning of parameters are quite empirical. Furthermore, the performance of the controllers cannot be guaranteed under certain unforeseen large disturbances.

With the introduction of differential geometric methods, various stabilizing control results are reported based on

nonlinear multimachine power system models [1, 2]. However, differential geometric based nonlinear controller designs require the exact knowledge of the system dynamics. Imprecise knowledge will degrade the performance of the controller designs. Since it is impossible to make the assumption that the complex power system dynamics can be known accurately, these controller designs cannot be widely accepted.

In order to overcome the limitation of above methods and to enhance the robustness of the power system, numerous results on the decentralized nonlinear robust control of power systems have appeared [3-6]. Some model uncertainties are considered even though most of the controller designs are still based on the differential geometric or backstepping methodologies. In all these papers, the stability and robustness of the control system were demonstrated using Lyapunov analysis.

Neural networks have been proven to be an excellent tool for function approximation and therefore they are used to approximate nonlinear systems. Recently, NN were applied to the design of decentralized controllers [7, 8]. In these papers, NNs are used to approximate the unknown nonlinear dynamics of the subsystems and to compensate for the unknown nonlinear interactions. Though local measured information is used in the controller design of subsystems, the coordination of subsystem controllers and the transient performance can be guaranteed. These designs are applicable to a limited class of nonlinear systems. In [9], decentralized neural network control of large-scale systems is proposed for a class of nonlinear systems in the ideal case when no approximation errors are present. However, algebraic constraints are not considered. The proposed work extends the NN-based decentralized controller design to power systems that are modeled using differential algebraic equations (DAE). In the DAE model, the differential equations are used to model the dynamics of the generators, and the algebraic equations are used to model the power flow constraints. Before the controller design, the algebraic equations are first transformed into the differential equations based on circuit theory. After that, bounds of the interconnection terms are analyzed for the transformed model. Subsequently, NN-based decentralized controller design is presented. It can be concluded that all of the signals in the closed loop are uniformly ultimately bounded uniformly ultimately bounded. Simulations with a 3-machine power system demonstrate the effectiveness of the proposed decentralized NN controller design.

The rest of the paper is organized as follows. Section II presents a brief background on universal approximation property of neural networks and stability of nonlinear system.

¹Wenxin Liu and Dave A. Cartes are with the Center for Advanced Power Systems, Florida State University, Tallahassee, 32310, USA (e-mail: {wliu, dave}@caps.fsu.edu)

²Jagannathan Sarangapani, Ganesh K. Venayagamoorthy, and Donald C. Wunsch II, are with the Department of Electrical and Computer Engineering, University of Missouri - Rolla, MO 65401 USA, (e-mails: {sarangap, ganeshv, and dwunsch}@umr.edu)

Section III presents the model transformation, and bound analysis. The decentralized neural network controller design is presented in section IV. Simulation results are provided in section V, and finally, the conclusion in Section VI.

II. BACKGROUND

The following mathematical notions are required for the system approximation using NNs and stability analysis for the design of an adaptive NN controller.

A. Approximation Property of NN

The commonly used property of NN for control is its function approximation and adaptation capability [10]. Let $f(x)$ be a smooth function from $R^n \rightarrow R^m$, then it can be shown that, as long as x is restricted to a compact set $S \in R^n$, for some sufficiently large number of hidden-layer neurons, there exist a set of weights and thresholds such that

$$f(x) = W^T \varphi(x) + \varepsilon(x) \quad (1)$$

where x is the input vector, $\varphi(\cdot)$ is the activation function, W is the weight matrix of the output layer and $\varepsilon(x)$ is the approximation error. Equation (1) means that a NN can approximate any continuous function in a compact set. In fact, for any choice of a positive number ε_N , one can find a NN such that $\varepsilon(x) \leq \varepsilon_N$ for all $x \in S$. For suitable function approximation, $\varphi(x)$ must form a basis [11].

For a two layer NN, $\varphi(x)$ is defined as $\varphi(x) = \sigma(V^T x)$, where V is the weight matrix of the first layer and $\sigma(x)$ is the sigmoid function. If V is fixed, then the only design parameter in the NN is W matrix and this NN becomes a simplified version of function link network (one layer NN) which is easier to train. It has been shown in [12] that $\varphi(x)$ can form a basis if V is chosen randomly. The larger the number of the hidden layer neurons N_h , the smaller is the approximation error $\varepsilon(x)$. Baron shows that the NN approximation error $\varepsilon(x)$ for one-layer NN is fundamentally bounded by a term of the order $(1/n)^{2/d}$, where n is the number of fixed basis functions and d is the dimension of the input to the NN [10].

B. Stability of Systems

Consider the nonlinear system given by

$$\begin{aligned} \dot{x} &= f(x, u) \\ y &= h(x) \end{aligned} \quad (2)$$

where $x(t)$ is a state vector, $u(t)$ is the input vector and $y(t)$ is the output vector [13]. The solution to (2) is uniformly ultimately bounded (UUB) if for any U , a compact subset of R^n , and all $x(t_0) = x_0 \in U$ there exists an $\varepsilon > 0$ and a number $T(\varepsilon, x_0)$ such that $\|x(t)\| < \varepsilon$ for all $t \geq t_0 + T$.

III. POWER SYSTEM MODEL TRANSFORMATION AND BOUND ANALYSIS

Large-scale power systems can be represented using Differential Algebraic Equations (DAE) [14]. The differential and algebraic equations represent the generator dynamics and power flow constraints respectively and they are given by

$$\begin{cases} \frac{d\delta_i}{dt} = \omega_i - \omega_s \\ 2H_i \frac{d\omega_i}{dt} = T_{mi} - E'_{qi} I_{qi} - (X_{qi} - X'_{di}) I_{di} I_{qi} \\ T'_{d0i} \frac{dE'_{qi}}{dt} = -E'_{qi} - (X_{di} - X'_{di}) I_{di} + E_{fdi} \end{cases} \quad (3)$$

and

$$\begin{cases} 0 = P_i^{inj} - V_i \sum_{j=1}^N V_j Y_{ij} \cos(\theta_i - \theta_j - \phi_{ij}) \\ 0 = Q_i^{inj} - V_i \sum_{j=1}^N V_j Y_{ij} \sin(\theta_i - \theta_j - \phi_{ij}) \end{cases} \quad (4)$$

where I_{di} and I_{qi} satisfy the following equations.

$$\begin{cases} V_i \sin(\delta_i - \theta_i) - X_{qi} I_{qi} = 0 \\ V_i \cos(\delta_i - \theta_i) + X'_{di} I_{di} - E'_{qi} = 0 \end{cases} \quad (5)$$

where n is the number of generators, N is the number of the buses, δ_i is the power angle of the i th generator in rad, ω_i is the rotating speed of the i th generator in rad/s, ω_s is the synchronous machine rotating speed in rad/s, H_i is the inertia constant in seconds, T_{mi} is the mechanical input power in p.u., E'_{qi} is the q-axis internal transient electric potential of the i th generator in p.u., E_{fdi} is the control signal in p.u., P_i^{inj} and Q_i^{inj} are the injected active and reactive power at bus i in p.u., $V_i \angle \theta_i$ is the voltage at bus i , and $Y_{ij} \angle \phi_{ij}$ is admittance between bus i and bus j .

The difficulty encountered during the controller design for the above DAE based model is the manipulation of algebraic constraints. According to (5), we can see that I_{di} and I_{qi} in (3) are functions of local measured variables δ_i and $V_i \angle \theta_i$. Since $V_i \angle \theta_i$ is subjected to algebraic equation constraints (4), I_{di} and I_{qi} can be expressed as a function of the states of the differential equations only. This procedure is discussed next.

According to circuit theory, the voltages and injected currents at the generator buses satisfy the following equation.

$$\bar{V} = Z_{bus} \bar{I} \quad (6)$$

where $\bar{V} = [V_1, \dots, V_n]^T$ and $\bar{I} = [I_1, \dots, I_n]^T$ are all $n \times 1$ vectors, $Z_{bus} = R + jX$ is a $n \times n$ matrix of the equivalent impedance of the network.

The dynamic circuit of the synchronous generator can be represented using the following figure [14].

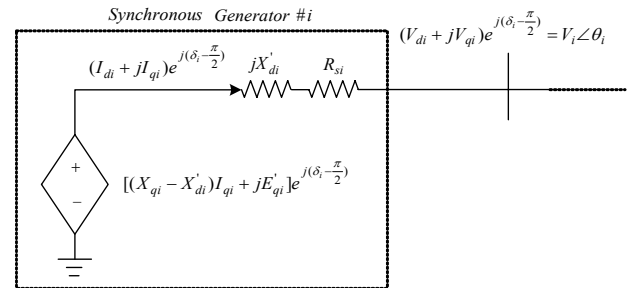

Fig 1: Dynamic circuit of the synchronous generator

According to the above figure, we have

$$\bar{I} = (I_d + jI_q) \cdot e^{j(\delta - \frac{\pi}{2})} \quad (7)$$

and

$$\bar{V} = [(X_q I_q - R_s I_d) + j(E'_q - X'_d I_d - R_s I_q)] \cdot e^{j(\delta - \frac{\pi}{2})} \quad (8)$$

where $I_d = [I_{d1}, \dots, I_{dn}]^T$, $I_q = [I_{q1}, \dots, I_{qn}]^T$, $\delta = [\delta_1, \dots, \delta_n]^T$, $X_q = [X_{q1}, \dots, X_{qn}]^T$, $X'_d = [X'_{d1}, \dots, X'_{dn}]^T$, $E'_q = [E'_{q1}, \dots, E'_{qn}]^T$, and $R_s = [R_{s1}, \dots, R_{sn}]^T$ are all $n \times 1$ vectors, "." denotes "dot multiplication".

Since R_s elements are usually very small, we assume R_s is a null vector. Substituting (7) and (8) into (5) to get

$$[X_q I_q + j(E'_q - X'_d I_d)] \cdot e^{j(\delta - \frac{\pi}{2})} = (R + jX) [(I_d + jI_q) \cdot e^{j(\delta - \frac{\pi}{2})}] \quad (9)$$

That is

$$\begin{cases} X_q I_q \sin \delta + (E'_q - X'_d I_d) \cos \delta = R(I_d \sin \delta + I_q \cos \delta) - X(I_q \sin \delta - I_d \cos \delta) \\ (E'_q - X'_d I_d) \sin \delta - X_q I_q \cos \delta = R(I_q \sin \delta - I_d \cos \delta) + X(I_d \sin \delta + I_q \cos \delta) \end{cases} \quad (10)$$

Considering the i -th elements of the above equations, we get

$$\begin{cases} E'_{qi} \cos \delta_i = \sum_{j=1}^n \{ [R_{ij} \sin \delta_j + (A_{ij} + X_{ij}) \cos \delta_j] I_{dj} + [-(B_{ij} + X_{ij}) \sin \delta_j + R_{ij} \cos \delta_j] I_{qj} \} \\ E'_{qi} \sin \delta_i = \sum_{j=1}^n \{ [(A_{ij} + X_{ij}) \sin \delta_j - R_{ij} \cos \delta_j] I_{dj} + [R_{ij} \sin \delta_j + (B_{ij} + X_{ij}) \cos \delta_j] I_{qj} \} \end{cases} \quad (11)$$

where R_{ij} and X_{ij} are the i, j -th element of matrix R and X respectively, and A and B are defined according to $A = \text{diag}[X'_{d1}, \dots, X'_{dn}]$ and $B = \text{diag}[X_{q1}, \dots, X_{qn}]$.

Equation (11) can be expressed using the following equation

$$Y = MX \quad (12)$$

where vectors X , Y and matrix M are defined as follows

$$X = [I_{d1}, I_{q1}, \dots, I_{di}, I_{qi}, \dots, I_{dn}, I_{qn}]^T$$

$$Y = [E'_{q1} \cos \delta_1, E'_{q1} \sin \delta_1, \dots, E'_{qi} \cos \delta_i, E'_{qi} \sin \delta_i]^T, \dots, E'_{qn} \cos \delta_n, E'_{qn} \sin \delta_n]^T$$

$$M = \begin{bmatrix} \alpha_{11} & \beta_{11} & \dots & \alpha_{1i} & \beta_{1i} & \dots & \alpha_{1n} & \beta_{1n} \\ \phi_{11} & \varphi_{11} & \dots & \phi_{1i} & \varphi_{1i} & \dots & \phi_{1n} & \varphi_{1n} \\ \vdots & \vdots & \vdots & \vdots & \vdots & \vdots & \vdots & \vdots \\ \alpha_{i1} & \beta_{i1} & \dots & \alpha_{ii} & \beta_{ii} & \dots & \alpha_{in} & \beta_{in} \\ \phi_{i1} & \varphi_{i1} & \dots & \phi_{ii} & \varphi_{ii} & \dots & \phi_{in} & \varphi_{in} \\ \vdots & \vdots & \vdots & \vdots & \vdots & \vdots & \vdots & \vdots \\ \alpha_{n1} & \beta_{n1} & \dots & \alpha_{ni} & \beta_{ni} & \dots & \alpha_{nn} & \beta_{nn} \\ \phi_{n1} & \varphi_{n1} & \dots & \phi_{ni} & \varphi_{ni} & \dots & \phi_{nn} & \varphi_{nn} \end{bmatrix} \quad (13)$$

The variables in M are defined according to

$$\begin{aligned} \alpha_{ij} &= M_{2i-1, 2j-1} = R_{ij} \sin \delta_j + (A_{ij} + X_{ij}) \cos \delta_j \\ \beta_{ij} &= M_{2i-1, 2j} = -(B_{ij} + X_{ij}) \sin \delta_j + R_{ij} \cos \delta_j \\ \phi_{ij} &= M_{2i, 2j-1} = (A_{ij} + X_{ij}) \sin \delta_j - R_{ij} \cos \delta_j \\ \varphi_{ij} &= M_{2i, 2j} = R_{ij} \sin \delta_j + (B_{ij} + X_{ij}) \cos \delta_j \end{aligned} \quad (14)$$

During the operation range of power system, M should always be a full rank matrix. This is proved during our simulation under different operating conditions. Thus the inverse matrix of M exist and I_{di} and I_{qi} can be expressed as linear combinations of E'_{qj} with the parameters $\phi_{ij}(\bar{\delta})$ and

$\psi_{ij}(\bar{\delta})$ defined as linear combinations of the $\sin \delta_i$ and $\cos \delta_i$ together with the parameters of the power systems.

$$\begin{cases} I_{di} = \sum_{j=1}^n \phi_{ij}(\bar{\delta}) E'_{qj} \\ I_{qi} = \sum_{j=1}^n \psi_{ij}(\bar{\delta}) E'_{qj} \end{cases} \quad (15)$$

where $\bar{\delta} = [\delta_1, \dots, \delta_n]^T$ denote all of the rotor angles.

Since the linear combination of bounded variables are always bounded, the bound of I_{di} and I_{qi} can be expressed using (16).

$$\begin{cases} |I_{di}| \leq \sum_{j=1}^n \Phi_{ij} |E'_{qj}| \\ |I_{qi}| \leq \sum_{j=1}^n \Psi_{ij} |E'_{qj}| \end{cases} \quad (16)$$

where constants Φ_{ij} and Ψ_{ij} are the bounds of $\phi_{ij}(\delta)$ and $\psi_{ij}(\delta)$ respectively. Note that we don't need to calculate the value of Φ_{ij} and Ψ_{ij} in our calculation of control signals. We only use these expressions to analyze the bounds of the interconnection terms.

To simplify the controller design, the third system state E'_q is substituted using a measurable variable P_{ei} and it is defined as

$$P_{ei} = E'_{qi} I_{qi} + (X_{qi} - X'_{di}) I_{di} I_{qi} \quad (17)$$

Thus the system dynamics can be transformed into

$$\begin{cases} \dot{\delta}_i = \omega_i - \omega_s \\ \dot{\omega}_i = \frac{\omega_s}{2H_i} T_{mi} - \frac{\omega_s}{2H_i} P_{ei} \\ \dot{P}_{ei} = -\frac{1}{T_{d0i}} P_{ei} + \frac{1}{T_{d0i}} v_i + \Delta_i(\cdot) \end{cases} \quad (18)$$

where the virtual control signal for the transformed system is defined as

$$v_i = E_{fdi} I_{qi} = \Delta v_i + v_{i0} \quad (19)$$

where v_{i0} is the reference value of v_i and Δv_i is the deviation of v_i from v_{i0} . $\Delta_i(\cdot)$ is called the interconnection term and defined as [15]

$$\Delta_i(\cdot) = (X_{qi} - X'_{di}) I_{di} I_{qi} + E'_{qi} \dot{I}_{qi} + (X_{qi} - X'_{di}) (\dot{I}_{di} I_{qi} + I_{di} \dot{I}_{qi}) \quad (20)$$

According to (19), we can calculate E_{fdi} as long as I_{qi} is not zero. The term $|\Delta_i(\cdot)|$ can be expressed as a sum of subsystem states since our controller design requires the bound on the interconnection terms. Consequently, the following assumption can be applied to get the bounds.

Assumption 1: The excitation voltage E_{fdi} can be at most k times as large as $E_{qi} = E'_{qi} + (X_{di} - X'_{di}) I_{di}$ [5].

The above assumption is very important to obtain the bound on the interconnection terms. According to this assumption and (16), we have

$$\begin{aligned} |\dot{E}'_{qi}| &= \frac{1}{T'_{d0i}} |E_{fdi} - E_{qi}| \leq \frac{k}{T'_{d0i}} |E_{qi}| \\ &\leq \frac{k}{T'_{d0i}} |E'_{qi} + (X_{di} - X'_{di}) \sum_{j=1}^n \phi_j(\bar{\delta}) E'_{qj}| \leq \sum_{j=1}^n \Gamma_{ij} |E'_{qj}| \end{aligned} \quad (21)$$

where Γ_{ij} is some positive number.

Remark 1: We are not assuming that E_{fdi} and E'_{qi} are bounded, but we are making an assumption that their rate of increase is bounded during the analysis of \dot{E}'_{qi} . Thus this assumption is a mild one.

Now let's analyze the bound of the interconnection terms $|\Delta_{i1}(\cdot)|$. Based on (15), (16), and (21), it is easy to verify that there exist some positive constants A_{ij} , B_{ij} , C_{ij} , and D_{ij} , such that the following inequalities exist.

$$\begin{aligned} |(X_{qi} - X_{di}) I_{di} I_{qi}| &\leq \sum_{j=1}^n A_{ij} E_{qj}'^2 \\ |E'_{qi} \dot{I}_{qi}| &\leq \sum_{j=1}^n B_{ij} E_{qj}'^2 \\ |(X_{qi} - X'_{di}) \dot{I}_{di} I_{qi}| &\leq \sum_{j=1}^n C_{ij} E_{qj}'^2 \\ |(X_{qi} - X'_{di}) I_{di} \dot{I}_{qi}| &\leq \sum_{j=1}^n D_{ij} E_{qj}'^2 \end{aligned} \quad (22)$$

Thus we can conclude that $|\Delta_i(\cdot)|$ is bounded according to

$$|\Delta_i(\cdot)| \leq \sum_{j=1}^n E_{ij} E_{qj}'^2 \quad (23)$$

where $E_{ij} = A_{ij} + B_{ij} + C_{ij} + D_{ij}$

Define $x_{i1} = \delta_i$, $x_{i2} = \Delta\omega_i = \omega_i - \omega_s$, $x_{i3} = -\frac{\omega_s}{2H_i} \Delta P_{ei}$,

$u_i = -\frac{\omega_s}{2H_i T'_{d0i}} \Delta v_i$ and $k_i = -\frac{1}{T'_{d0i}}$, then the above system model can be transformed into the following simplified system

$$\begin{cases} \dot{x}_{i1} = x_{i2} \\ \dot{x}_{i2} = x_{i3} \\ \dot{x}_{i3} = k_i x_{i3} + u_i + \Delta_i(\cdot) \end{cases} \quad (24)$$

The output of the system is the power angle denoted as $y_i = x_{i1}$. Our objective is to make the system output track the desire set point, which is $\delta_i \rightarrow \delta_i^d$.

In (24), the definition of $\Delta_i(\cdot)$ is different from that of (20). The bound of the new $\Delta_i(\cdot)$ is given as

$$\begin{aligned} |\Delta_i(\cdot)| &\leq \frac{\omega_s}{2H_{\min} T'_{d0\min}} |P_{e0} - X_0|_{\max} + \frac{\omega_s}{2H_{\min}} \sum_{j=1}^n E_{ij} E_{qj}'^2 \\ &\leq \delta_{i0} + \sum_{j=1}^n \delta_{ij} E_{qj}'^2 \end{aligned} \quad (25)$$

IV. CONTROLLER DESIGN

In this section, a NN based controller designs is proposed. The controller design is introduced using a theorem and is described as follows.

A Controller Design

First consider the i -th subsystem. Define the filter error r_i as

$$r_i = [\Lambda_i^T \quad 1]^T x_i \quad (26)$$

where $x_i = [x_{i1}, x_{i2}, x_{i3}]^T$ and $\Lambda_i = [\lambda_{i1}, \lambda_{i2}]^T$ is an appropriately chosen coefficient vector such that $x_i \rightarrow 0$ as $r_i \rightarrow 0$ (i.e. $s^2 + \lambda_{i2}s + \lambda_{i1} = 0$ is Hurwitz). Taking the derivative of r_i to get

$$\dot{r}_i = [0 \quad \Lambda_i^T] x_i + f_i(\cdot) + u_i + \Delta_i(x) + d_i \quad (27)$$

For subsystem without interconnection term $\Delta_i(x)$, the control signal u_i can be chosen as

$$u_i = -K_i r_i - [0 \quad \Lambda_i^T] x_i - f_i(\cdot) \quad (28)$$

where $K_i > 0$ is the design parameter.

To compensate the effects of interconnection terms, NN are used here. According to the NN approximation theory, it can be concluded that there exists a NN such that

$$W_i^T \Phi_i(X_i) + \varepsilon_i = \sum_{j=1}^n E_{ji} E_{qj}'^2 \quad (29)$$

where $X_i = [E_{qi}'^2, 1]^T$ is the input vector to the NN, ε_i is the bounded NN approximation error given by $|\varepsilon_i| \leq \varepsilon_{iM}$.

Thus, the actual control signal can be chosen as

$$u_i = -K_i r_i - [0 \quad \Lambda_i^T] x_i - f_i(\cdot) - \text{sgn}(r_i) \hat{W}_i^T \Phi_i(X_i) \quad (30)$$

The Lyapunov function for the i -th subsystem is chosen according to

$$V_i = \frac{1}{2} r_i^2 + \frac{1}{2} \tilde{W}_i^T \Gamma_i^{-1} \tilde{W}_i \quad (31)$$

where \tilde{W}_i is the weight estimation error defined as

$$\tilde{W}_i = \hat{W}_i - W_i \quad (32)$$

and $\Gamma_i > 0$ is another design parameter.

Taking the derivative of V_i to get

$$\begin{aligned} \dot{V}_i &= -K_i r_i^2 - |r_i| \hat{W}_i^T \Phi_i(X_i) + r_i \Delta_i(x) + \tilde{W}_i^T \Gamma_i^{-1} \dot{\tilde{W}}_i \\ &\leq -K_i r_i^2 - |r_i| \hat{W}_i^T \Phi_i(X_i) + |r_i| \sum_{j=1}^n E_{ij} E_{qj}'^2 + \tilde{W}_i^T \Gamma_i^{-1} \dot{\tilde{W}}_i \end{aligned} \quad (33)$$

Thus the Lyapunov function for the overall system becomes

$$V = \sum_{i=1}^n V_i \quad (34)$$

$$\dot{V}_i \leq \sum_{i=1}^n \left[-K_i r_i^2 - |r_i| \hat{W}_i^T \Phi_i(X_i) + |r_i| \sum_{j=1}^n E_{ij} E_{qj}'^2 + \tilde{W}_i^T \Gamma_i^{-1} \dot{\tilde{W}}_i \right] \quad (35)$$

Note that

$$\sum_{i=1}^n \sum_{j=1}^n E_{ij} E_{qj}'^2 = \sum_{i=1}^n \sum_{j=1}^n E_{ji} E_{qi}'^2 \quad (36)$$

Thus

$$\dot{V} \leq \sum_{i=1}^n \left[-K_i r_i^2 - |r_i| \hat{W}_i^T \Phi_i(X_i) + |r_i| W_i^T \Phi_i(X_i) + |r_i| \varepsilon_i^M + \tilde{W}_i^T \Gamma_i^{-1} \dot{\tilde{W}}_i \right] \quad (37)$$

$$\leq \sum_{i=1}^n \left[-K_i r_i^2 - |r_i| \tilde{W}_i^T \Phi_i(X_i) + \tilde{W}_i^T \Gamma_i^{-1} \dot{\tilde{W}}_i + |r_i| \varepsilon_{iM} \right]$$

The weights updating rules is changed to

$$\dot{\hat{W}}_i = \Gamma_i |r_i| \Phi_i(X_i) - \alpha_i \Gamma_i \hat{W}_i \quad (38)$$

Then (37) becomes

$$\dot{V} \leq \sum_{i=1}^n (-K_i r_i^2 - \alpha_i \tilde{W}_i^T \hat{W}_i + |r_i| \varepsilon_{iM}) \quad (39)$$

Since

$$\begin{aligned} -\alpha_i \tilde{W}_i^T \hat{W}_i &\leq -\alpha_i \tilde{W}_i^T (\tilde{W}_i + W_i) \\ &\leq -\alpha_i |\tilde{W}_i|^2 + \alpha_i |\tilde{W}_i| |W_i| \leq -\frac{\alpha_i}{2} |\tilde{W}_i|^2 + \frac{\alpha_i}{2} W_{i\max}^2 \end{aligned} \quad (40)$$

and

$$\varepsilon_{iM} |r_i| \leq \frac{r_i^2}{2} + \frac{1}{2} \varepsilon_{iM}^2 \quad (41)$$

Thus,

$$\dot{V} \leq \sum_{i=1}^n [- (K_i - \frac{1}{2}) r_i^2 - \frac{\alpha_i}{2} |\tilde{W}_i|^2 + \frac{\alpha_i}{2} W_{i\max}^2 + \frac{1}{2} \varepsilon_{iM}^2] \quad (42)$$

For simplification, define $\delta = \sum_{i=1}^n \frac{\alpha_i W_{i\max}^2 + \varepsilon_{iM}^2}{2}$. If the selection

of design parameters K_i and α_i , such that $K_i > \gamma + \frac{1}{2}$, and

$\alpha_i \geq \gamma \lambda_{\max}(\Gamma_i^{-1})$, then we get

$$\dot{V} \leq \sum_{i=1}^n \left[- (K_i - \frac{1}{2}) r_i^2 - \frac{\alpha_i}{2} |\tilde{W}_i|^2 \right] + \delta \leq -\gamma \sum_{i=1}^n [r_i^2 + \tilde{W}_i^T \Gamma_i^{-1} \tilde{W}_i] + \delta \leq -\gamma V + \delta \quad (43)$$

Theorem 1: Consider the closed-loop system consisting of system (24), the control signal (30), and the NN weight updating laws (38). For bounded initial conditions, all signals in the closed loop system remain uniformly ultimately bounded, and the system states x and NN weight estimates \hat{W} eventually converge to a compact set Ω .

$$\Omega = \left\{ r, \hat{W} \mid V < \frac{\delta}{\gamma} \right\} \quad (44)$$

Proof: From (44), we can see that if r_i and \tilde{W}_i are outside of the compact set defined as (45), then \dot{V} will remain negative definite until the systems state and the weight estimate errors enter the Ω . Thus, r_i and \tilde{W}_i are uniformly ultimately bounded. Furthermore, since W_i exist and are bounded, then \hat{W}_i are also bounded. Considering (26) and the boundedness of r_i , we can conclude that \dot{x} is bounded. Using (28), we conclude that control signal u is also bounded.

Thus, all signals in the closed loop system remain bounded, and the system state vector x , and NN weight estimates eventually converge to a compact set Ω [16].

Remark 2: In the proposed weight updates, persistency of excitation condition is not required. Weight updates using equation (38) is similar to σ -modification in the standard adaptive control.

Remark 3: The weights of the hidden layer are randomly chosen initially between 0 and 1 and fixed, therefore, not adapted. The initial weights of the output layer are just set to zero and then adapted online according to (38). There is no

preliminary off-line learning phase, and stability will be provided by the outer tracking loop until the NN learns. This is a significant improvement over other NN control techniques where one must find some initial stabilizing weights, generally a difficult task for complex nonlinear systems over a wide range of operating conditions.

V. SIMULATION STUDIES

The proposed decentralized NN controller design is tested with the classical WSCC 3-machine 9-bus system, which is shown in Fig. 2. The parameters of the system and the operating point information can be found in [14].

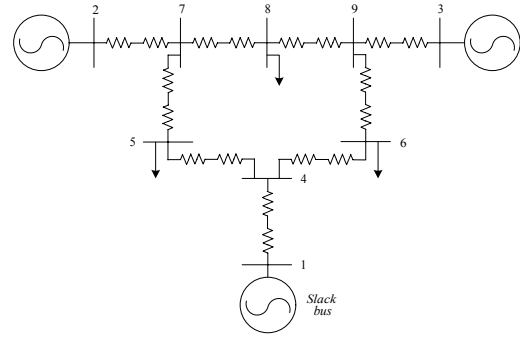

Fig. 2. Configuration of a three machines power system.

The design parameters of the controllers are the same and chosen as $A_i = [6, 9]$, $K_i = 3$, $\Gamma_i = 3$, $\alpha_i = 3$. Each neural network is selected to have ten neurons in the hidden layer and logarithmic sigmoid transfer functions.

Two kinds of operating conditions are used to test the proposed controller design. The first one is a 3-phase short circuit test and the second one is a load change. The 3-phase short circuit fault occurs near bus 7 at the end of line5-7 at 1s, the fault is cleared at 1.05s by opening line5-7, and line5-7 is restored at 2s. During the load change test, the load of bus 5 is doubled at 1s and then restored to its original value at 2s. For both tests, two kinds of simulation results are presented, which are without control and with the proposed NN control.

A. 3-phase short circuit tests

A.1. Without excitation control

Figs. 3-4 show the system responses to the 3-phase short circuit fault when there are no excitation controllers in the system.

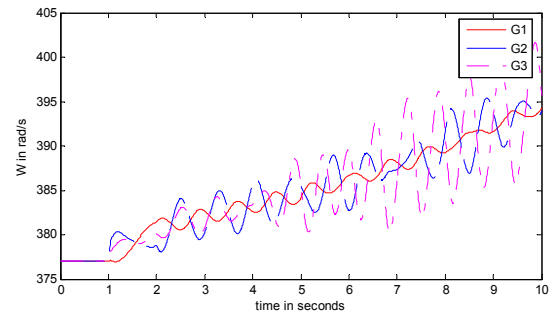

Fig. 3. Rotor speeds in response to the 3-phase short circuit fault

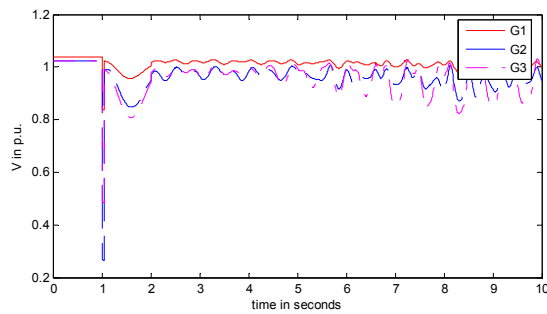

Fig. 4. Terminal voltages in responses to the 3-phase short circuit fault

From the simulation results we can see different modes of oscillations, which are resulted by interactions between generators. It is important to note that the system will settle down to some operating point eventually but the oscillations will persist for a long time.

A.2. With the decentralized NN control

Figs. 5-7 show the system responses to the 3-phase short circuit fault under the proposed controller. From these simulation results, it can be seen that the decentralized NN controllers overcome the interactions between the generators effectively. Although some of the signals in the control system may change abruptly but they will still remains bounded.

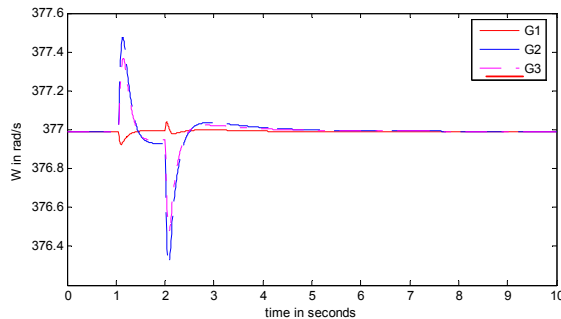

Fig. 5. Rotor speeds in response to the 3-phase short circuit fault

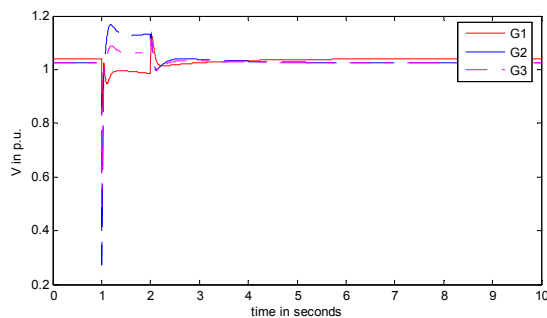

Fig. 6. Terminal voltages in responses to the 3-phase short circuit fault

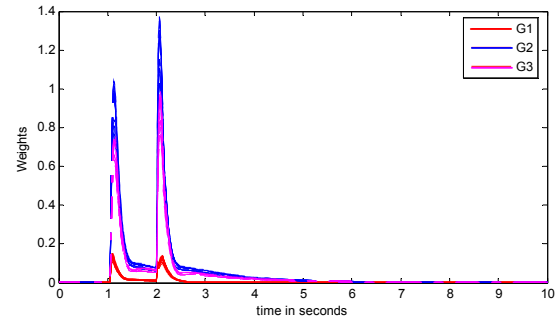

Fig. 7. Weights updating process during the 3-phase short fault

B. Load change tests

B.1. Without excitation control

Figs. 8-9 show the system response to the load change without excitation controllers. Simulation results demonstrate the needs for advanced controller designs.

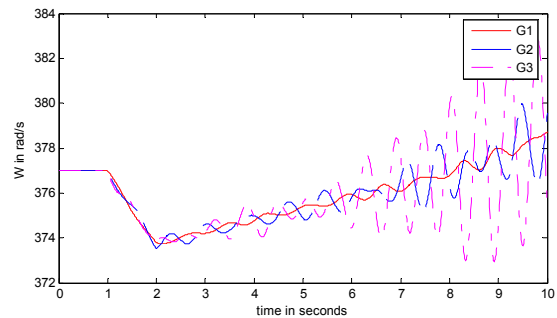

Fig. 8. Rotor speeds in response to the load change

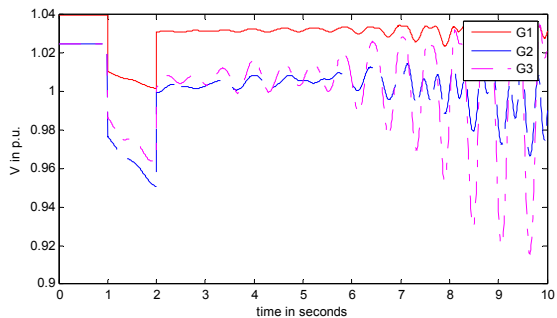

Fig. 9. Terminal voltages in responses to the load change

B.2. With the decentralized NN control

Figs. 10-12 show the system response to the load change under the proposed decentralized NN controller. Simulation results demonstrate that the proposed controller can damp out multimachine power system oscillation effectively for this kind of operating condition also.

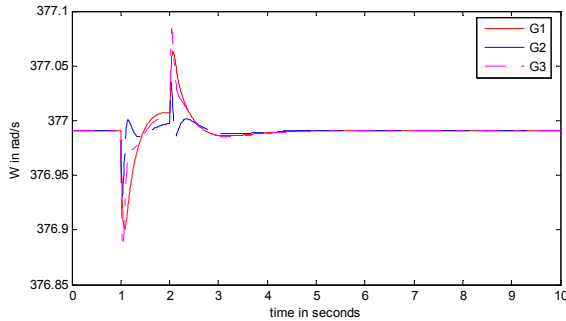

Fig. 10. Rotor speeds in response to the load change

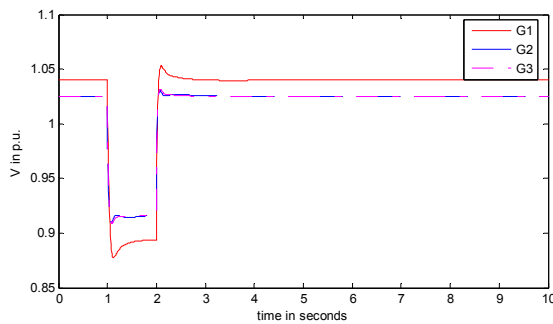

Fig. 11. Terminal voltages in responses to the load change

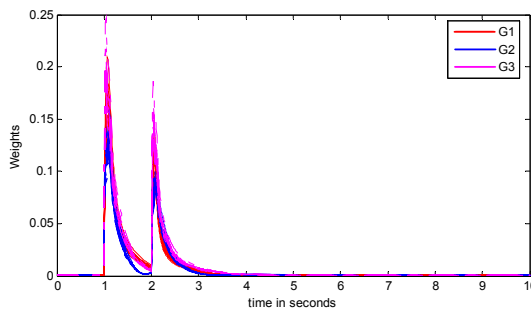

Fig. 12. Weights updating process during the load change

From the simulation results, we can see that the proposed controller designs can damp out the system oscillations effectively. Although the calculations of control signal use local information only, the controller can overcome the interaction s effectively.

VI. CONCLUSION

This paper introduced a NN based decentralized controller designs for the excitation control of large-scale power systems. The model used for NN decentralized controller design not only includes the differential equations of the generators but also the algebraic equations representing the power flow

constraints. Although only local measurable/calculatable signals to calculate the subsystem control input, the coordination of the subsystem controller and the transient performance was guaranteed by rigorous Lyapunov stability analysis. Simulation results under different operating conditions demonstrate that the proposed controller designs render good performance. Future work may include considering more practical power system model.

REFERENCES

- [1] Q. Lu, and Y. Sun, "Nonlinear stabilizing control of multimachine power systems", *IEEE Transactions on Power Systems*, Vol. 4, No. 1, pp. 236-241, February 1989.
- [2] J.W. Chapman, M.D. Ilic, C.A. King, L. Eng, and H. Kaufman, "Stabilizing a multimachine power system via decentralized feedback linearizing excitation control", *IEEE Transactions on Power Systems*, Vol. 8, No. 3, pp. 830-839, 1993.
- [3] S. Jain, F. Khorrami, and B. Fardanesh, "Adaptive nonlinear excitation control of power systems with unknown interconnections", *IEEE Transactions on Control Systems Technology*, Vol. 2, No. 4, pp. 436-446, 1994.
- [4] H. Jiang, H. Cai, J. F. Dorsey, and Z. Qu, "Toward a globally robust decentralized control for large-scale power systems", *IEEE Transactions on Control Systems Technology*, Vo. 5, No. 3, pp. 309-319, May 1997.
- [5] Y. Guo, D. J. Hill, and Y. Wang, "Nonlinear decentralized control of large scale power systems", *Automatica*, Vol. 36, No. 9, pp. 1275-1289, 2000.
- [6] L. Jiang, Q.H. Wu, and J. Y. Wen, "Decentralized nonlinear adaptive control of multimachine power systems via high-gain perturbation observer", *IEEE Transactions on Circuit Systems-I*, Vol. 51, No. 10, pp. October 2004.
- [7] S. Huang, K. K. Tan, and T. H. Lee, "Decentralized control design for large-scale systems with strong interconnections using neural networks. *IEEE Transactions on Automatic Control*, Vol. 48, No. 5, pp. 805-810, 2003.
- [8] J. T. Spooner and K. M. Passino, "Decentralized adaptive control of nonlinear systems using radial basis neural networks," *IEEE Transaction on Automatic Control*, vol. 44, pp. 2050-2057, Nov. 1999.
- [9] W. Liu, S. Jagannathan, D. C. Wunsch, and M. L. Crow, "Decentralized Neural Network Control of a Class of Large-Scale Systems with Unknown Interconnections", the 43rd IEEE Conference on Decision and Control, Atlantis, Bahamas, December 14-17, 2004.
- [10] A. R. Baron, "Universal approximation bounds for superposition of a sigmoid function", *IEEE Transaction on Information Theory*, vol. 39, no. 3, pp. 930-945, 1993.
- [11] N. Sadegh, "A perceptron network for functional identification and control of nonlinear systems", *IEEE Transaction on Neural Networks*, vol. 4, pp. 1823-1836, 1992.
- [12] B. Igel'nik and Y-H. Pao, "Stochastic choice of basis functions in adaptive function approximation and the functional-link net", *IEEE Transaction on Neural Networks*, vol. 6, no. 6, pp. 1320-1329, November 1995.
- [13] F. L. Lewis, S. Jagannathan, and A. Yesildirek, "Neural network control of robot manipulators and nonlinear systems", Taylor and Francis 1999.
- [14] P. W. Sauer and M.A. Pai, "Power system dynamics and stability", Prentice Hall, 1997.
- [15] Y. Wang, D. J. Hill, and G. Guo, "Robust decentralized control for multimachine power systems", *IEEE Transactions on Circuits and Systems*, Vol. 45, No. 3, pp. 271-279, 1998.
- [16] S. S. Ge and C. Wang, "Direct adaptive NN control of a class of nonlinear systems", *IEEE Transactions on Neural Networks*, Vol. 13, No. 1, pp. 214-221, 2002.