

1. Rigid bar  $ABC$  is supported by pin-connected axial member (1) and by a pin connection at  $C$ . A concentrated load of  $P = 6,300$  lb is applied to the rigid bar at  $A$ . Member (1) is a 2.75-in. wide by 1.25-in. thick rectangular bar made of steel with a yield strength of  $\sigma_Y = 36,000$  psi. The pin at  $C$  has an ultimate shear strength of  $\tau_{ult} = 60,000$  psi.

- (a) Determine the axial force in member (1).
- (b) Determine the factor of safety in member (1) with respect to its yield strength.
- (c) Determine the resultant reaction force acting at pin  $C$ .
- (d) If a minimum factor of safety of  $FS = 3.0$  with respect to the ultimate shear strength is required, determine the minimum diameter that may be used for the pin at  $C$ .

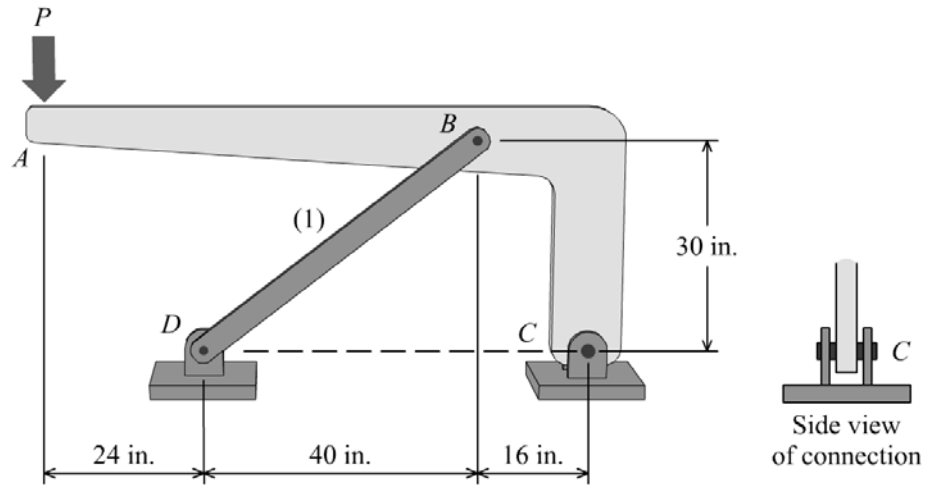

2. The compound axial member shown consists of three segments. Segment (1) is a solid 35-mm diameter rod, segment (2) is a solid 25-mm diameter rod, and segment (3) is a hollow tube with an outside diameter of 45 mm and a wall thickness of 8 mm. The elastic modulus and length of each segment are shown on the figure. Determine the deflection of point *A* and state whether point *A* deflects upward or downward.

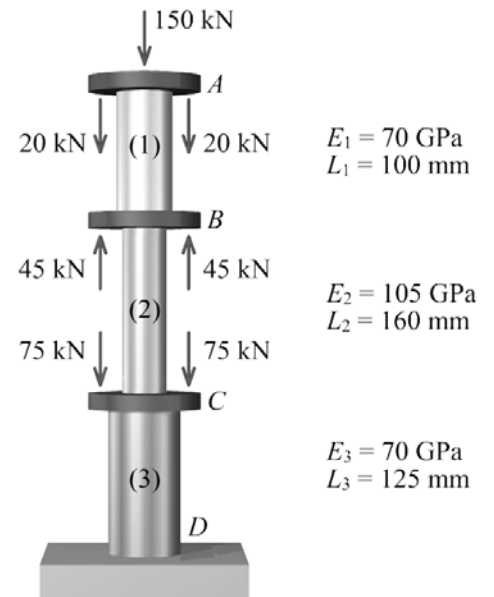

3. For the torsion assembly shown, the allowable shear stress for each shaft is 8 ksi and the shear modulus (or modulus of rigidity) is  $G = 11.2 \times 10^6$  psi.
- (a) Determine the largest magnitude of torque  $T_0$  that may be applied at  $A$  without exceeding the allowable shear stress in either shaft.
  - (b) Determine the angle of rotation at  $A$  that is produced by the torque magnitude determined in (a),

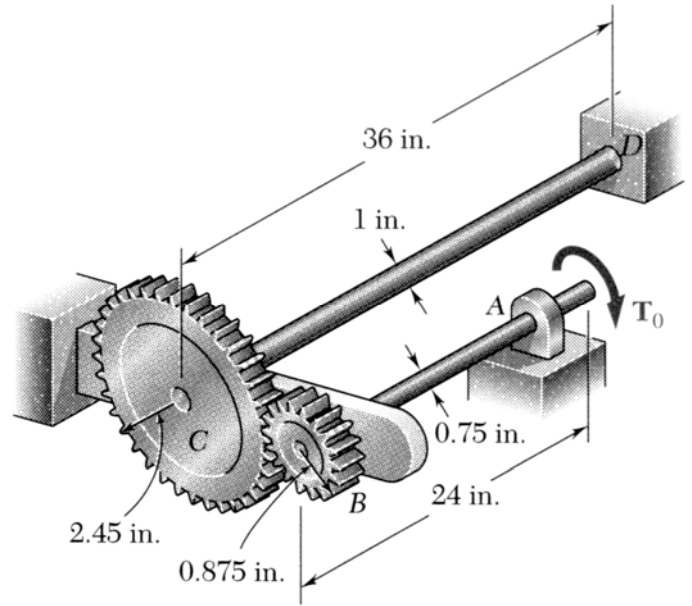

4. For the beam shown below, determine:
- (a) the maximum bending stress at any location in the beam.
  - (b) the maximum horizontal shear stress at any location in the beam.

Note: This problem is not asking for principal stresses.

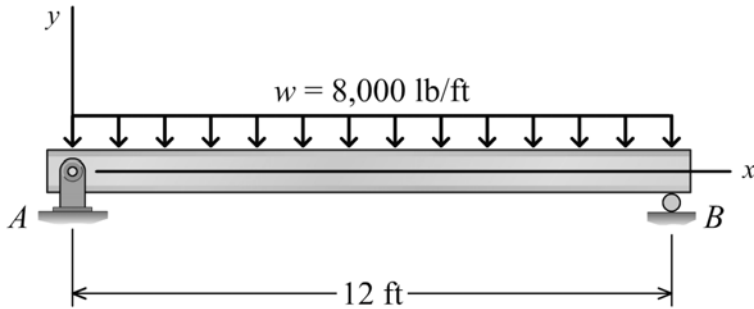

Beam diagram

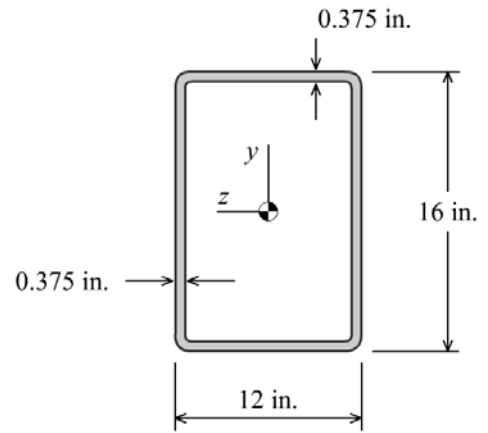

Cross-sectional dimensions

5. A thin brass ( $E = 100 \text{ GPa}$ ,  $\nu = 0.28$ ) plate is subjected to stresses  $\sigma_x$  and  $\sigma_y$  only. The normal stress in the  $y$  direction is known to be  $\sigma_y = 125 \text{ MPa}$ . If the strain gage measures a normal strain of  $+725 \mu\epsilon$  in the indicated direction, determine the magnitude of  $\sigma_x$  that acts on the plate.

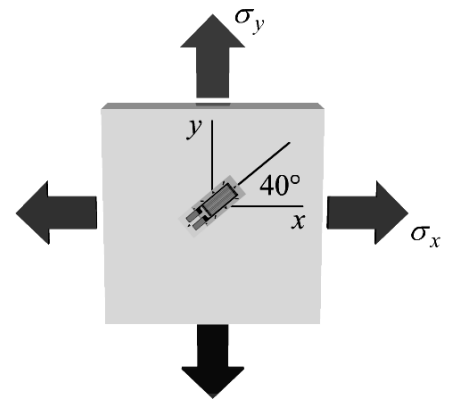

6. The cylindrical pressure vessel shown has an outside diameter of 780 mm and a wall thickness of 2.5 mm. The vessel is fabricated by spirally wrapping sheets of steel and then welding the sheets together along their longitudinal edges. If the cylinder contains gas at a gage pressure of 1.25 MPa, determine:
- (a) the normal stress acting perpendicular to the weld seams.
  - (b) the shear stress acting parallel to the weld seams.

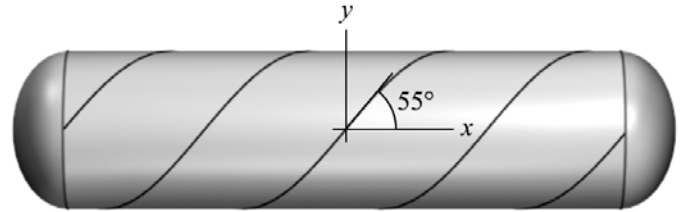

7. For the beam shown, determine the reaction force acting at roller support  $B$ . Assume  $EI = 1.2 \times 10^5 \text{ kN-m}^2$  for the entire beam.

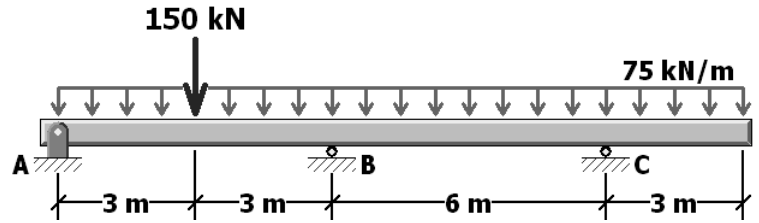

8. A pipe with an outside diameter of 220 mm and a wall thickness of 5 mm is subjected to the loads shown. The internal pressure in the pipe is 2,000 kPa. Determine the normal and shear stresses on the side of the pipe at point K. Show these stresses on a stress element.

