

HOOVER DAM:

Impacts on the Engineering Profession, America, and the World

J. David Rogers

for the

Distinguished Project Award

Association of Engineering Geologists

Annual Meeting Las Vegas, Nevada

September 21, 2005



UNITED STATES
DEPARTMENT OF THE INTERIOR
BUREAU OF RECLAMATION
COLORADO RIVER BASIN

MAP NO. 26380

SCALE OF MILES



1948

EXPLANATION

Irrigated Area U. S. Project

← Diversion from Basin

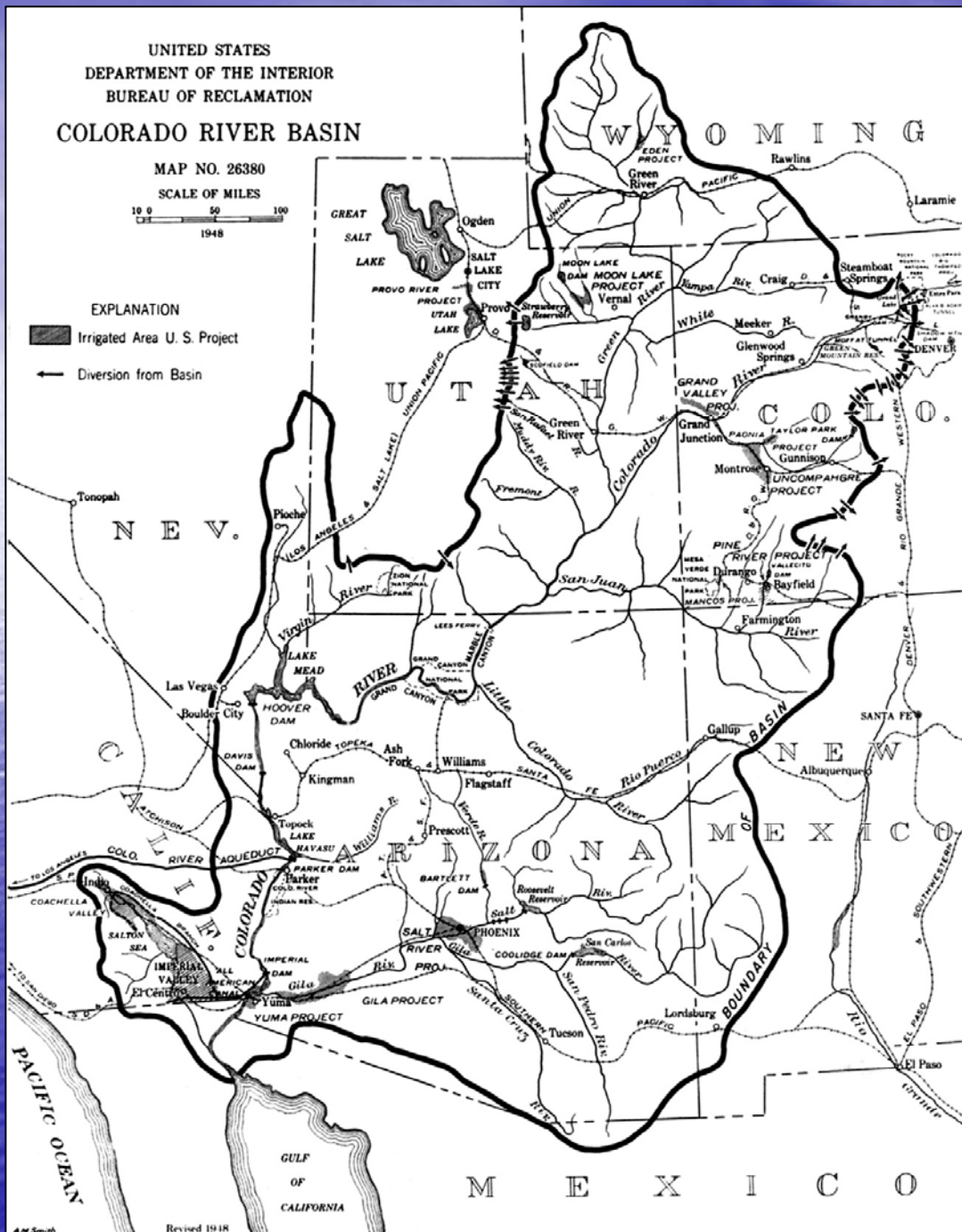

COLORADO RIVER BASIN

- Total watershed area of 246,000 square miles
- Shared by 7 states
- Only river in North America that flows through arid valleys

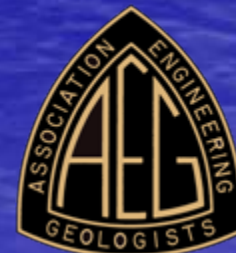

The Colorado River emptied into Lake Cahuilla; most of the time

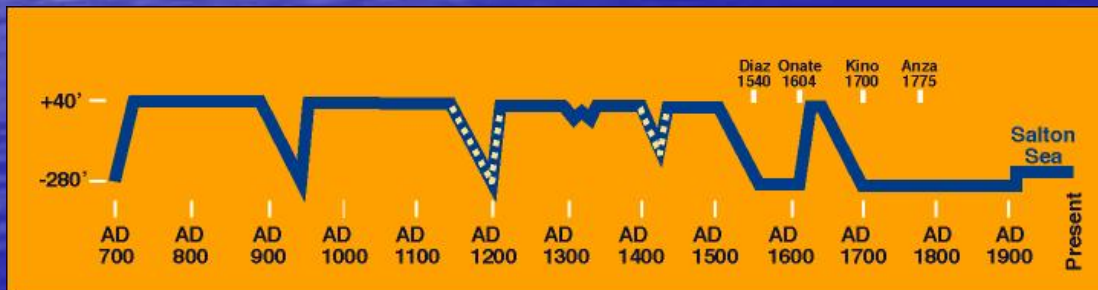

Out of Control flooding 1905-07



The breaches were caused by developers, but had to be repaired by the Southern Pacific Railroad at a cost of \$3 million; taking 2-1/2 years

EXPLANATION

- Elevations probably accurate within 3 feet
- Elevations probably accurate within 20 feet

Water-surface elevations represent average low water

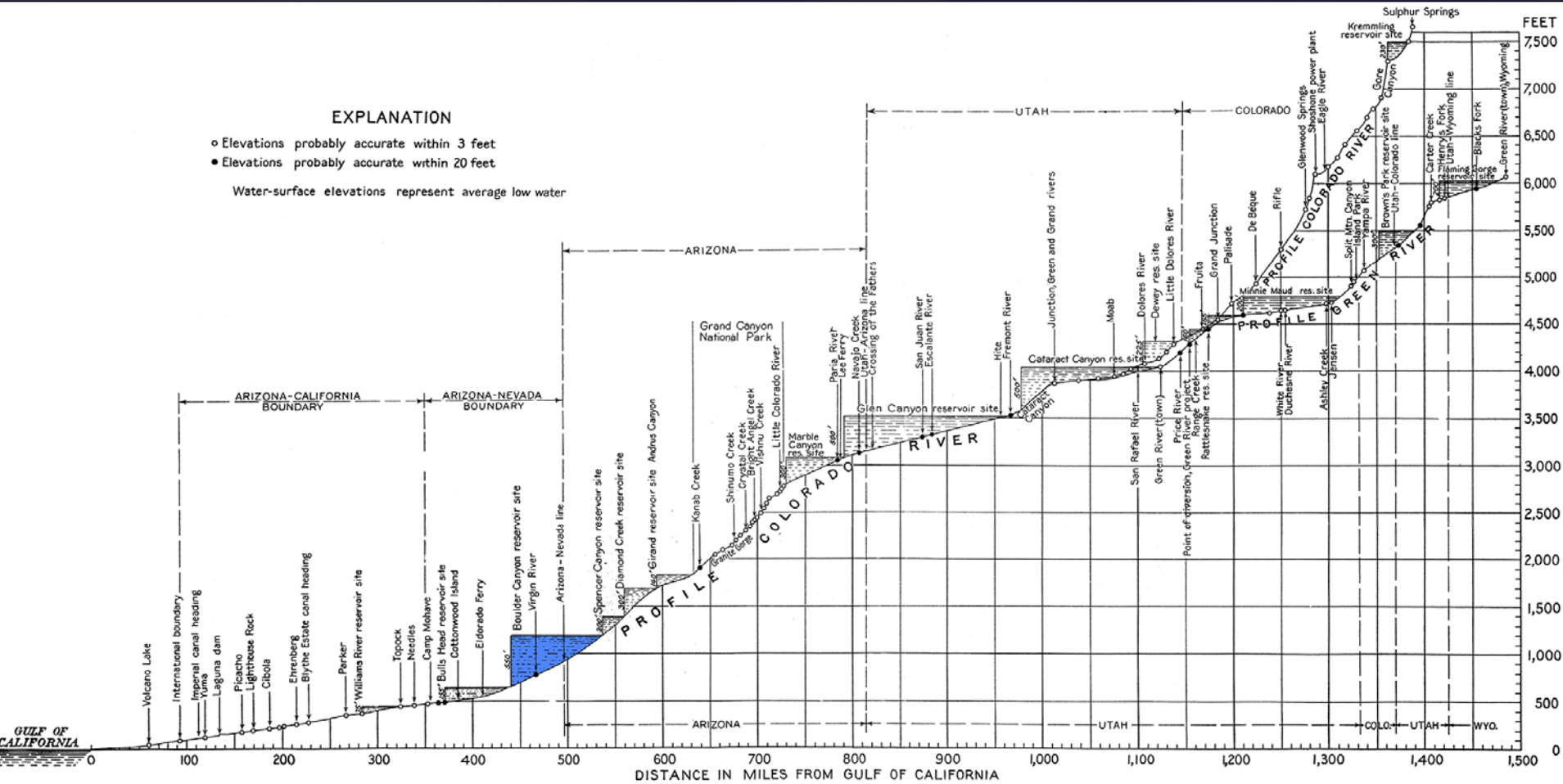

In 1922 the Reclamation Service proposes a scheme by which the Colorado River's water and power can be utilized to transform deserts into gardens, for the benefit of mankind

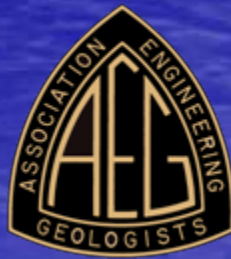

Project's Political Detractors

- Harry Chandler of Los Angeles Times owned 200,000 acres of farmland in Mexicali Valley. Mexican landowners siphoned off 50% of the aqueduct water serving the Imperial Valley.
- Southern California Edison didn't want government in utility business
- Arizona didn't want any part of any scheme that would send water to southern California by prior rights
- A prominent group of eastern engineers, led by New York's J. Waldo Smith, felt the project was overly ambitious in having to overcome so many unprecedented problems.

Project's Engineering Detractors

- Many did not feel Federal government should be involved in funding projects that ultimately benefited agribusinesses
- Dam was of unprecedented height; almost double the highest then in existence
- River's average flow and silt load not really known with certainty
- Too far from potential markets for electricity
- Site too remote, not able to provide gravity flow to Salt River Valley – Phoenix area



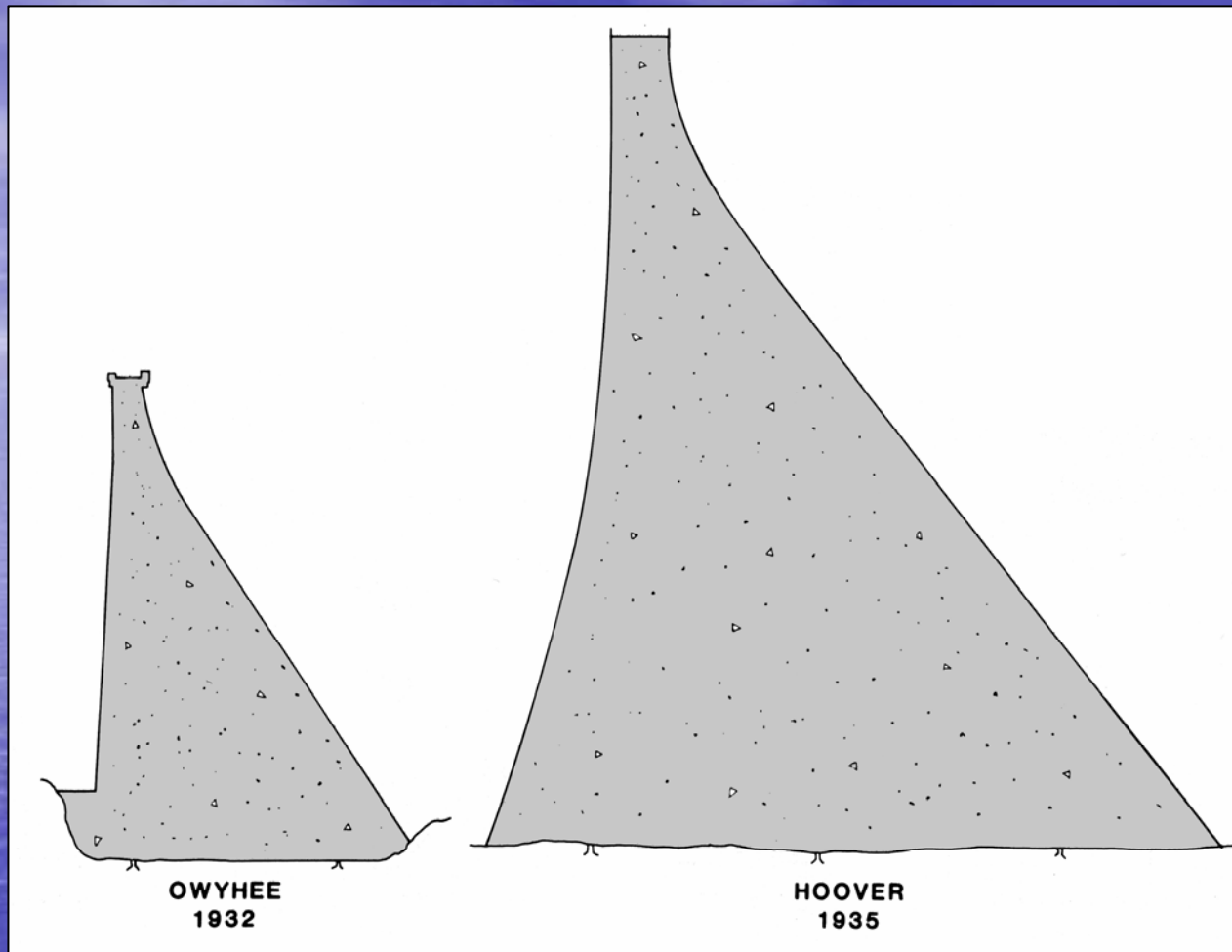

- **Unprecedented size:** Hoover Dam was almost twice as tall as the highest dam in the world, Owyhee, slated for completion in 1932!
- Owyhee Dam was designed by the same BurRec design team, led by Jack Savage.

The Colorado was America's most fickle river

- Named *Rio Colorado* by Spanish because of red color of highly turbid flow
- **Fifth highest silt load** of any river in the world (then known)
- Maximum recorded flow of **384,000 cfs** at Toppock in 1884
- Minimum recorded flow of **500 cfs** in 1911
- High-low flow ratio of **768:1**

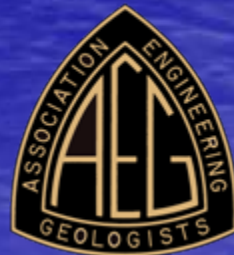

The Goal:

- 1.5 year supply of then entire Colorado River
- To Irrigate:
- Palo Verde Valley
- Yuma Valley
- Imperial Valley
- Coachella Valley

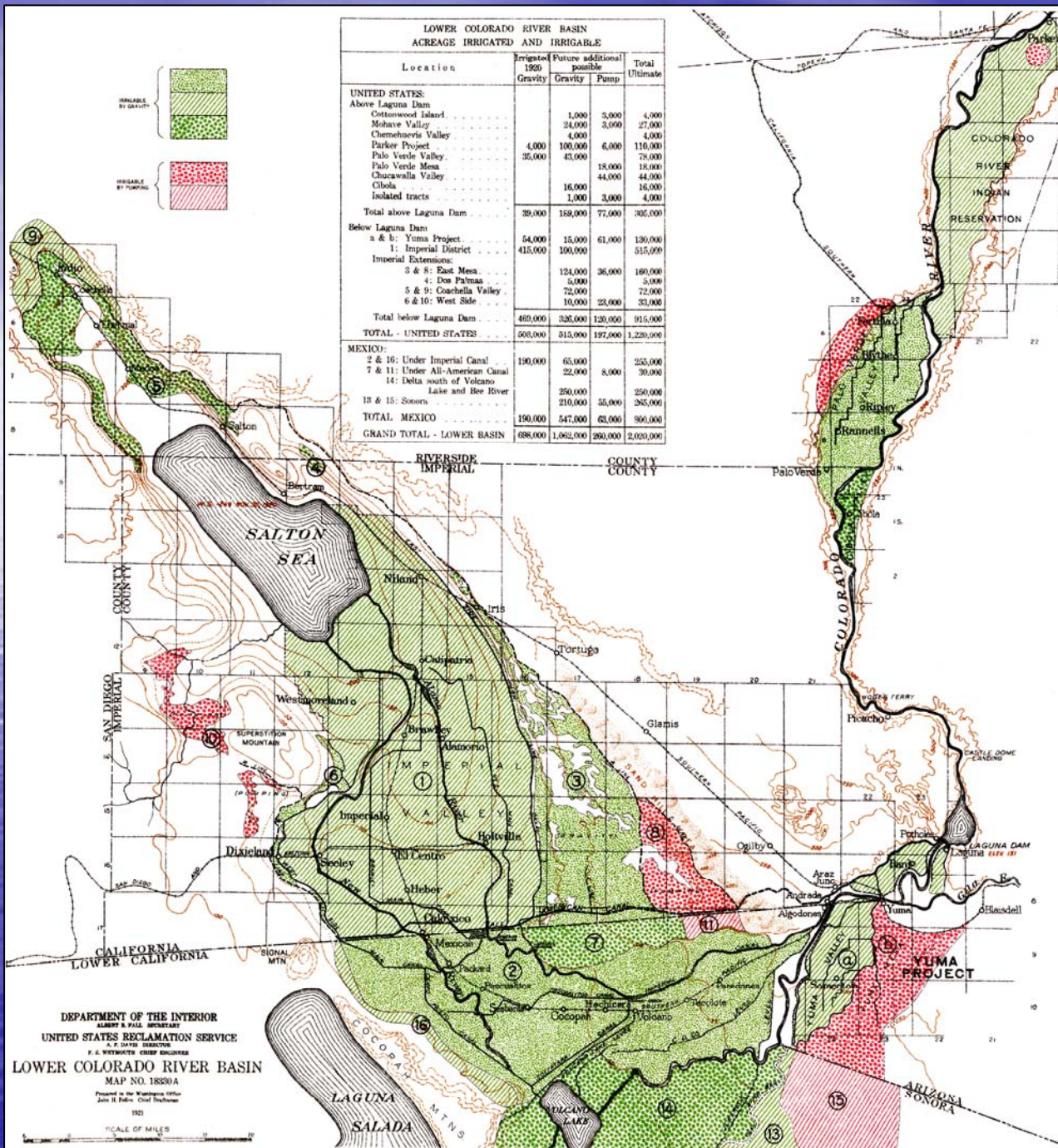

Initial studies focused on the head of **Boulder Canyon**, with a narrow gorge & granite outcrops

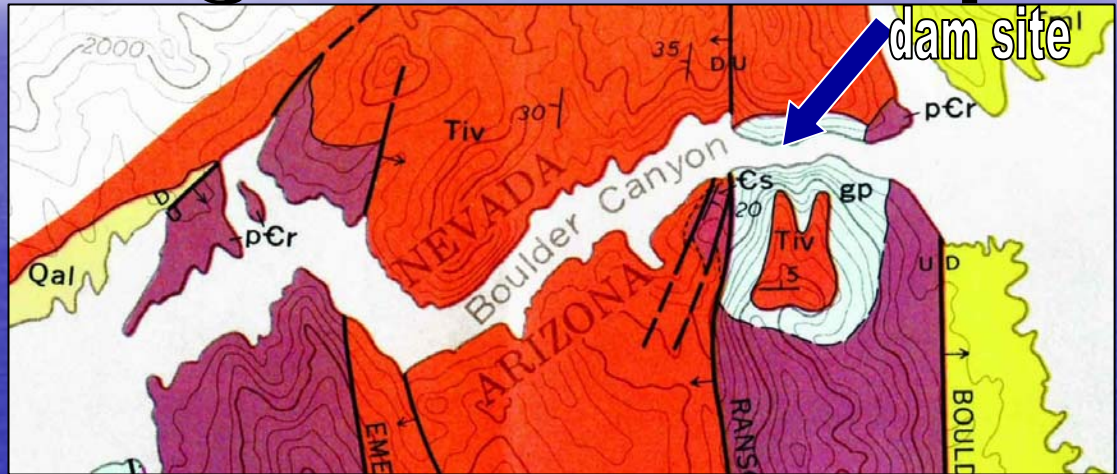
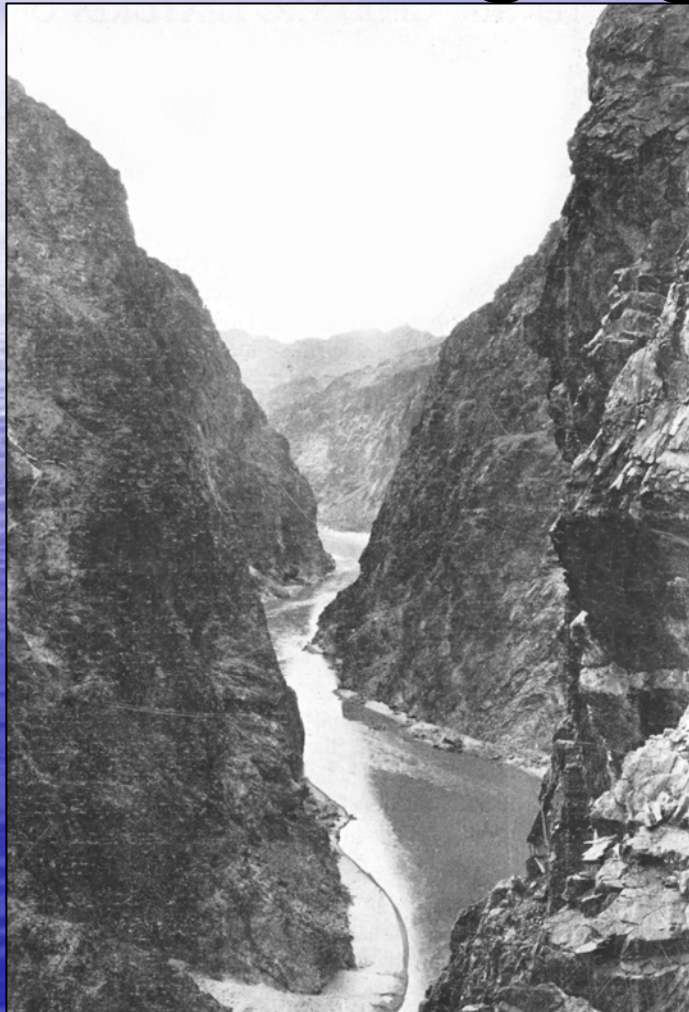

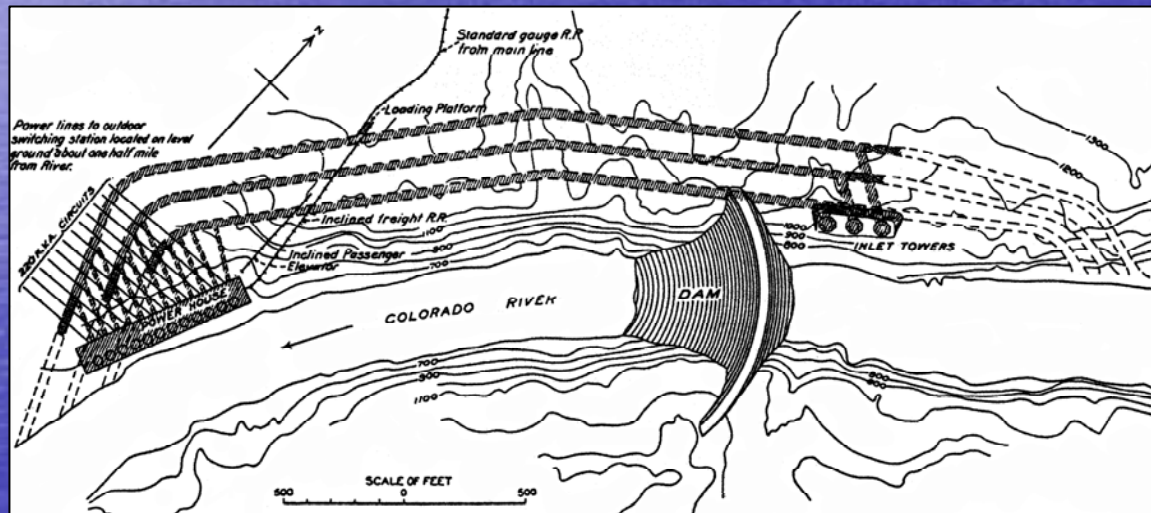
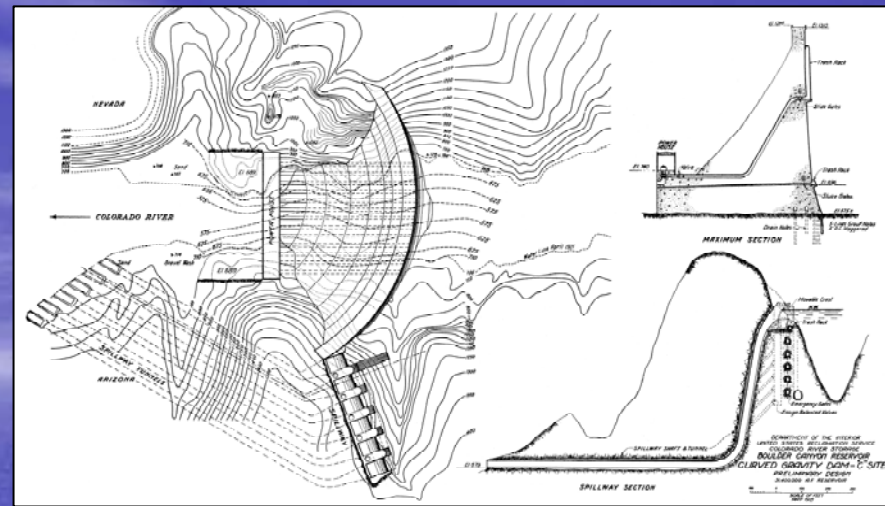
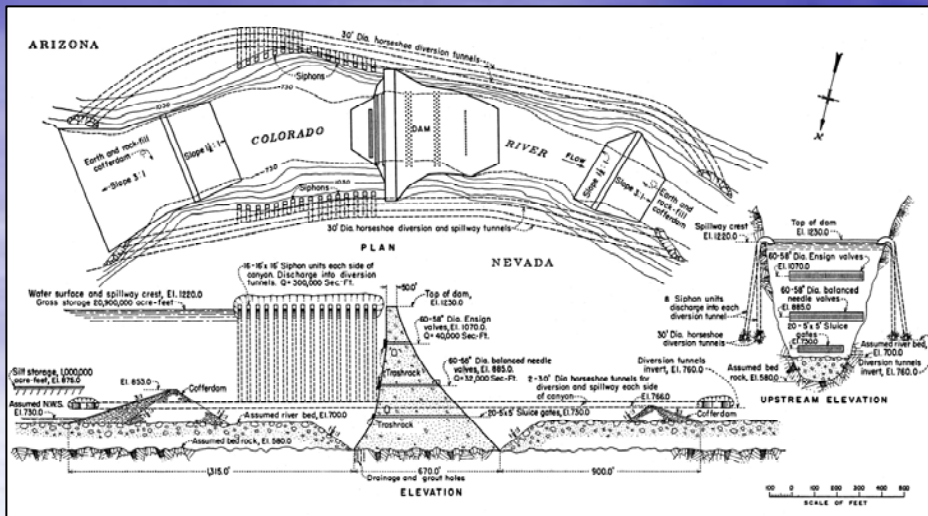

The design of **Boulder Dam** evolved throughout the 1920's; beginning with a straight concrete gravity dam; then arching the dam with increasing curvature; and finally, adding a powerhouse.

Surveys in Black Canyon

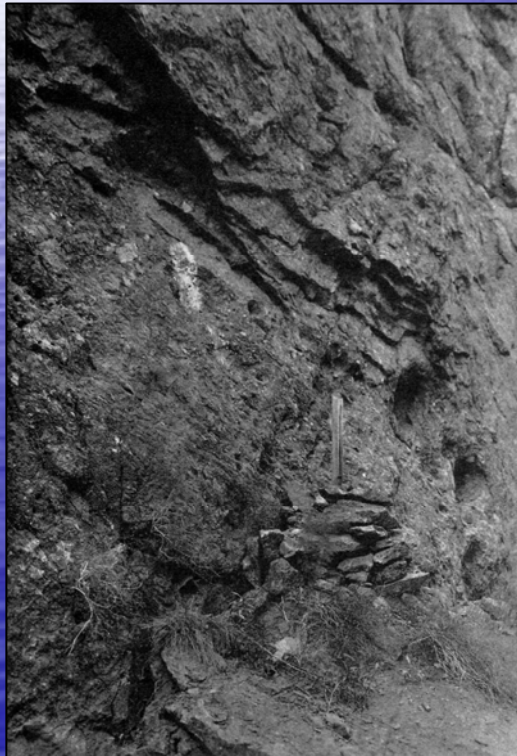

Engineer-geologist Homer Hamlin makes first survey of upper Black Canyon dam sites in the spring of 1920; marking axis of recommended site that is eventually chosen, 8-1/2 years later

PROBABLE FREQUENCY OF FLOOD DISCHARGES AT BLACK CANYON

| Discharge, Second-Feet | Frequency With Which Discharge May be Equaled or Exceeded |
|---------------------------|--|
| 130,000 | Once in 5 years |
| 160,000 | Once in 10 years |
| 190,000 | Once in 20 years |
| 230,000 | Once in 50 years |
| 260,000 | Once in 100 years |



The Colorado River Board expressed concern about how large the **maximum probable flood** might be after observing high water marks 80 feet above low water level at the head of Boulder Canyon (shown at left).

They concluded 320,000 cfs every 500 years and **450,000 cfs every 10,000 years**



- The untimely failure of the **St. Francis Dam** 35 miles north of Los Angeles in March 1928 killed at least 435 people
- Public outcry and concern following the failure of a brand new concrete gravity-arch dam constructed by the same people pushing for passage of the Boulder Canyon Project prompted the appointment of an **independent panel of experts** to review the Bureau of Reclamation's plans for the Boulder Canyon Project and advise Congress on its feasibility and practicality.

Colorado River Board May 1928



MGEN William L. Siebert (Chair), Elwood Mead (advisor), and included geologists Charles P. Berkey (Secretary) and Warren J. Mead; and engineers Daniel W. Mead and Robert Ridgway. In those days geologist wore ties, just like engineers.

Board investigates dam sites

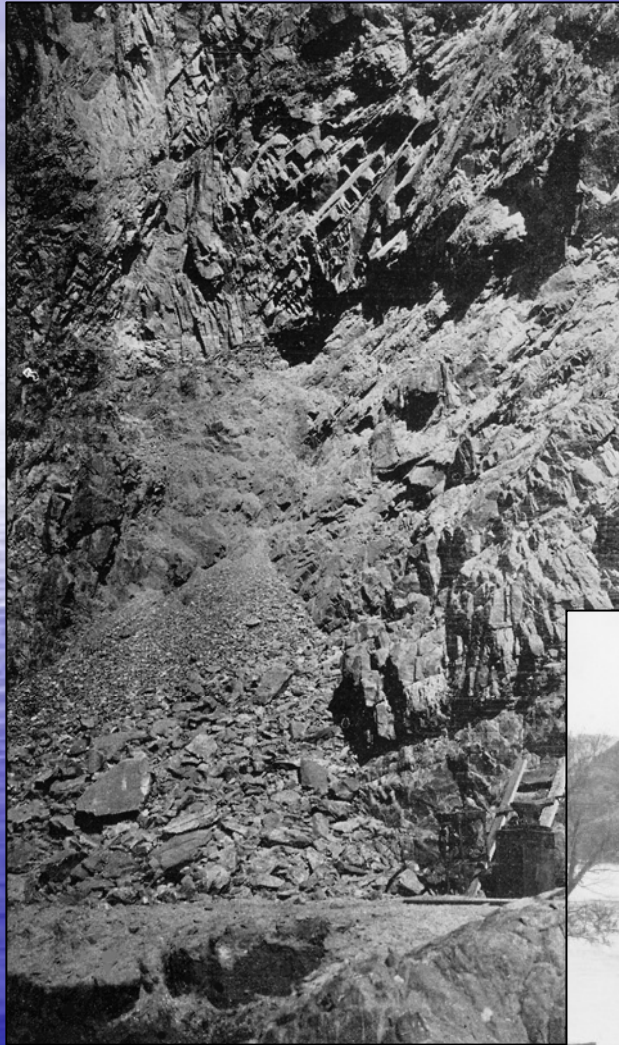

The Board's geologists raised a number of concerns that had not been addressed previously.

Colorado River Board chooses Black Canyon site in Nov 1928

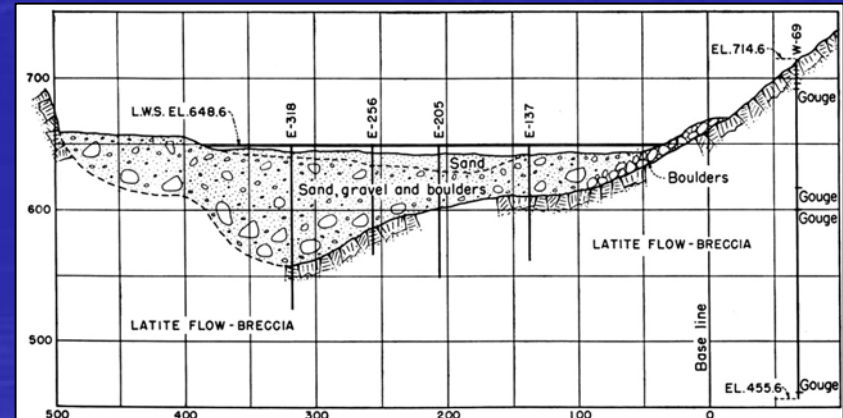
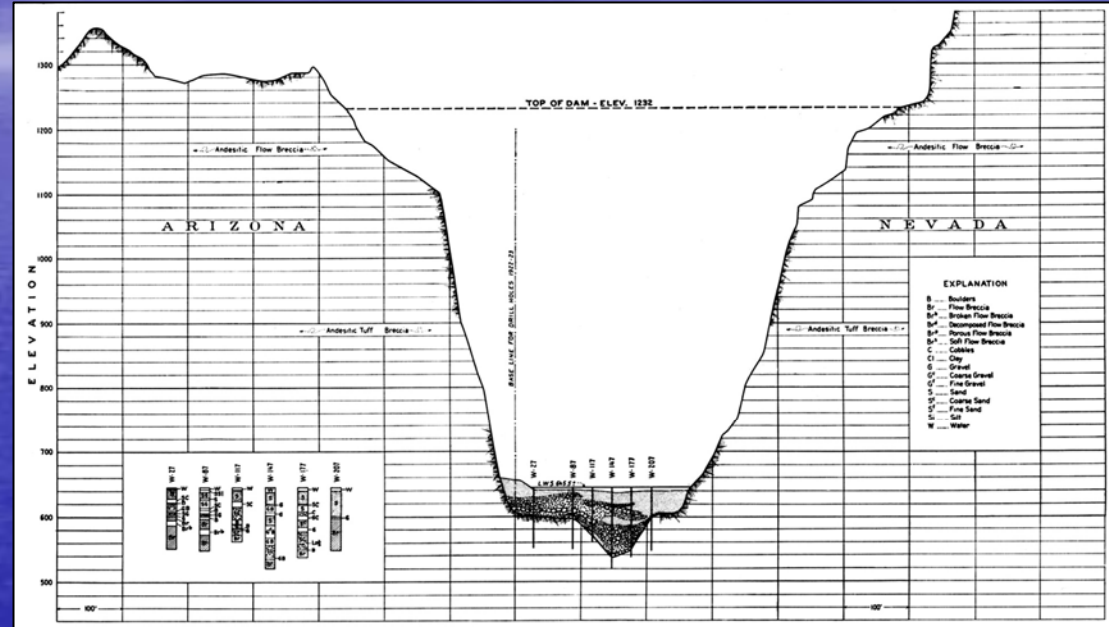

In November 1928, Board recommends design changes:

- Reduce foundation contact pressure from 40 tons per square foot (tsf) to 30 tsf;
- Increase capacity of river bypass diversion tunnels from 100,000 cfs to at least 200,000 cfs (25 yr flood);
- Spillway capacity should be $> 110,000$ cfs;
- Increase volume of flood storage;
- All-American Canal can be built north of the Mexican border; and
- Electricity generated by dam could be absorbed by the expanding market of greater Los Angeles.

Boulder Canyon Act introduced by California delegation in Congress as an annual ritual from 1922-28. Fourth version finally passes Senate in December 1928

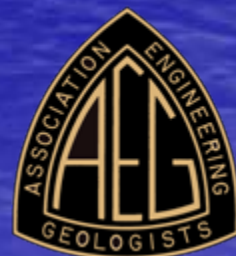
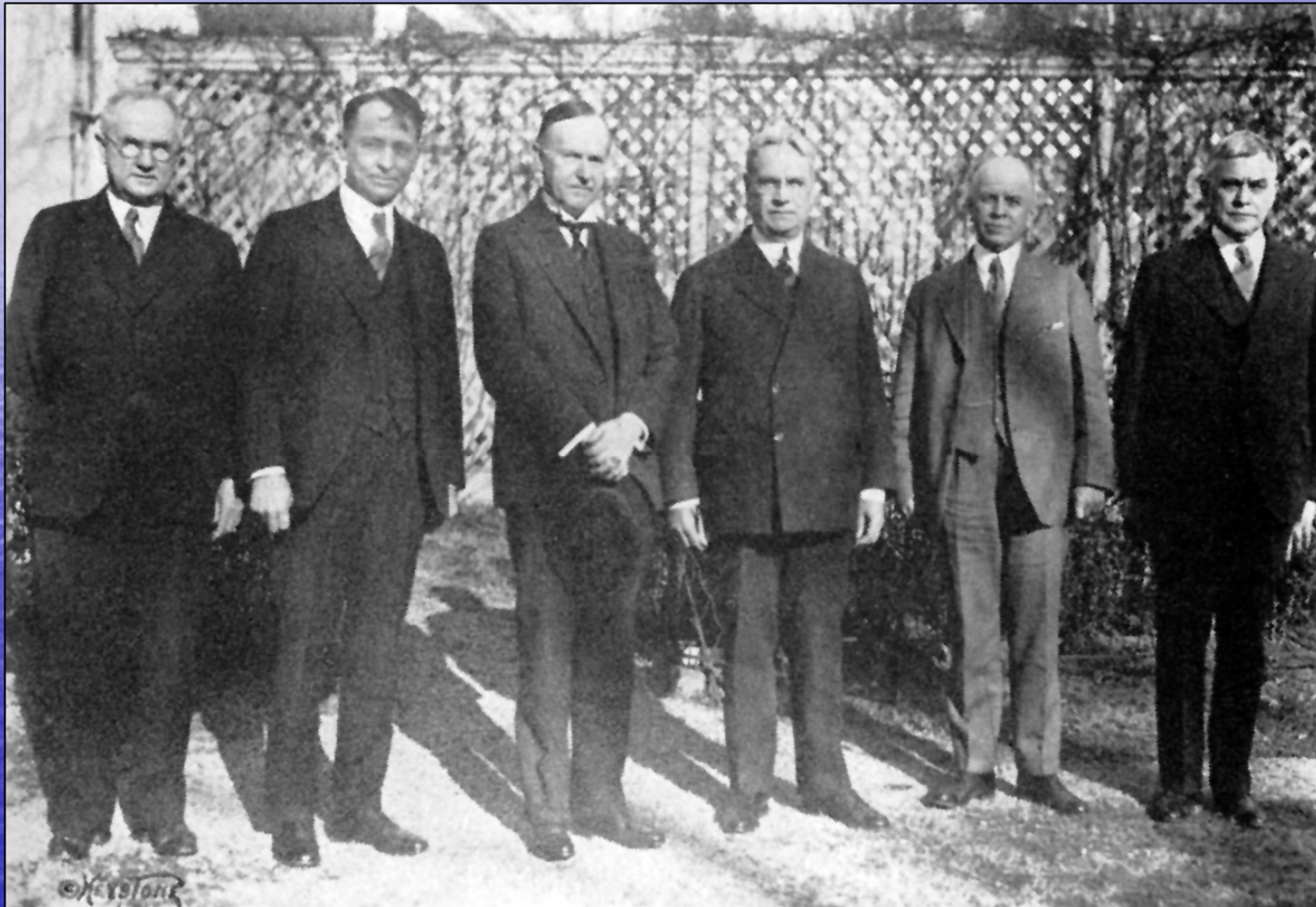

Leslie Ransome mapped the dam site

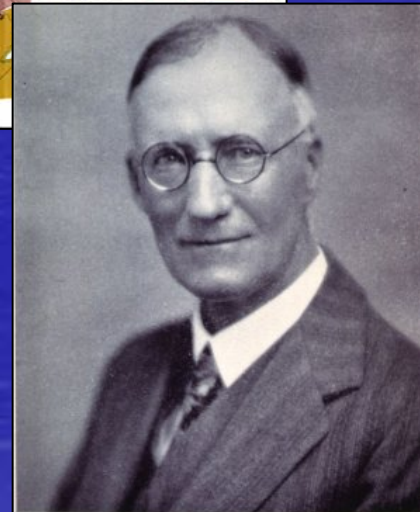
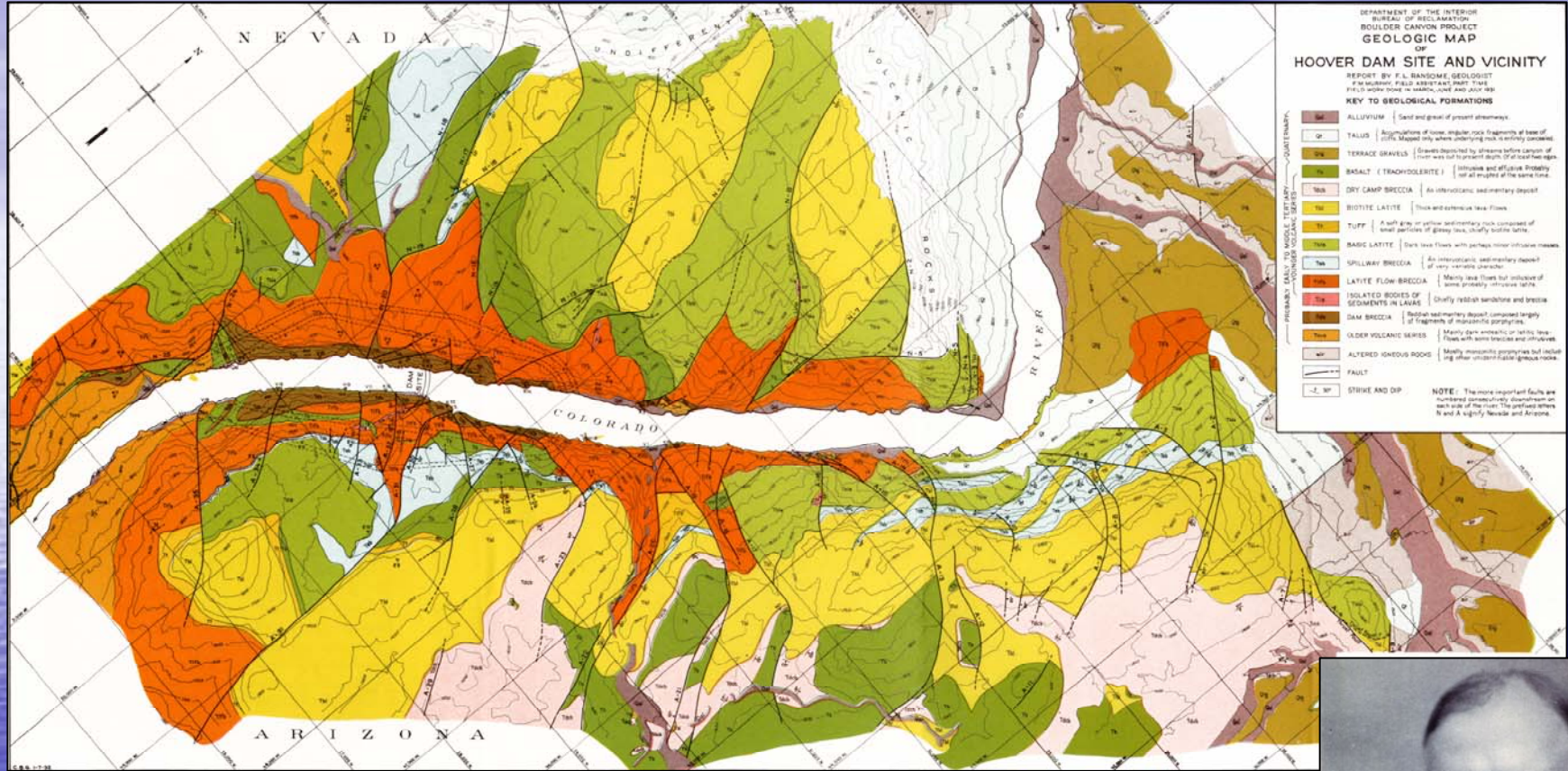

The dam was founded on a unit he called the **dam breccia**, a dense reddish unit composed of fragments of monzonitic porphyry; covered by a **latite flow breccia**. The deepest boring encountered dam breccia to a depth of 545 feet below river level.

Professor Chester Longwell mapped the reservoir area

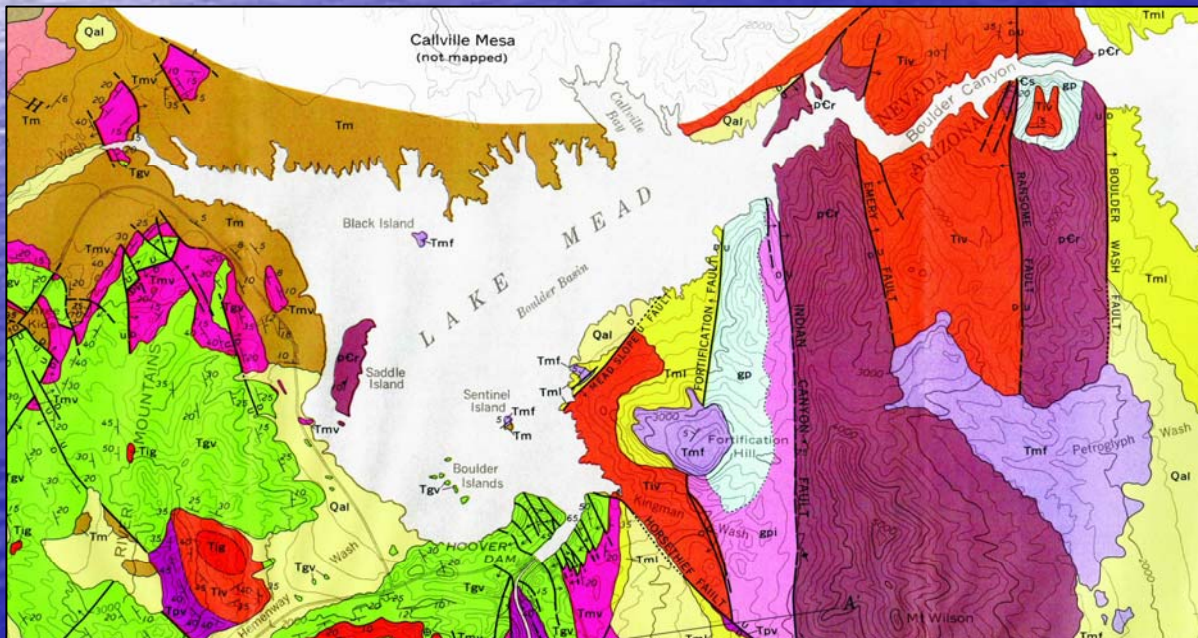
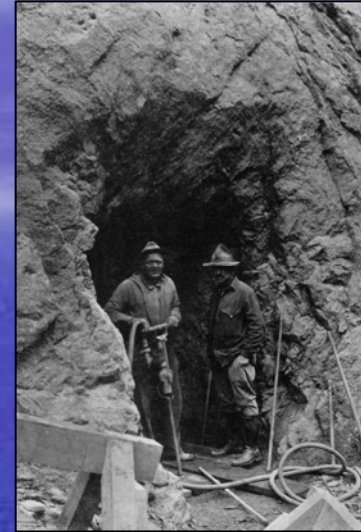

The Colorado River Board felt that the geology of the reservoir area should be mapped in detail before impoundment.

In April 1930 the decision is made to raise the dam 25 feet to increase flood storage

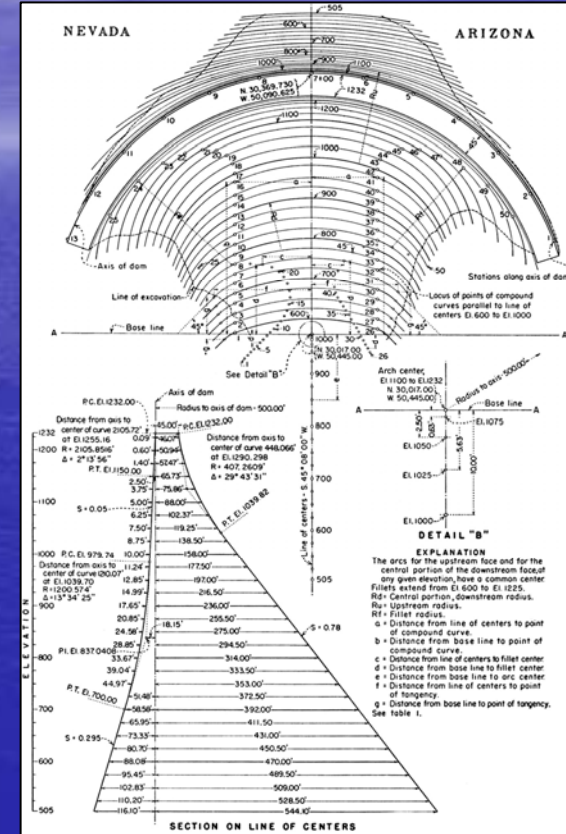
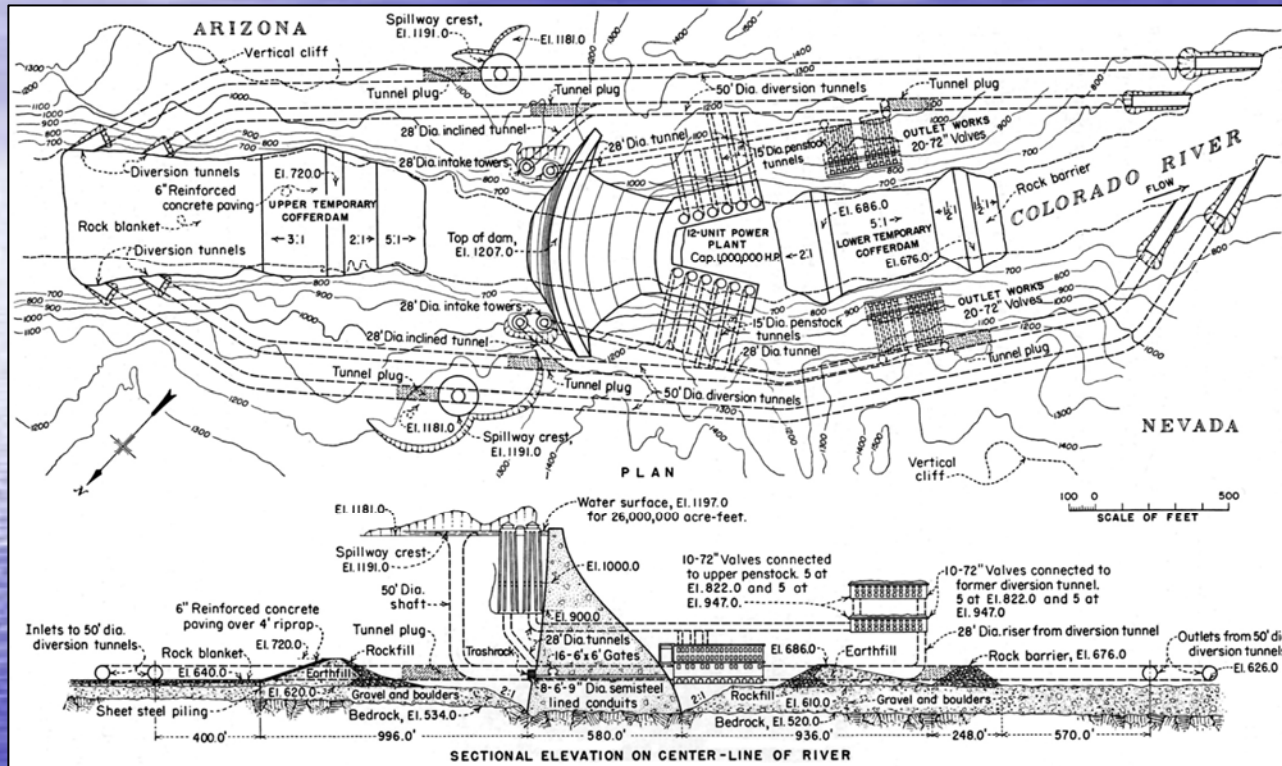

- Dam height now 730 ft; Crest elevation 1232 ft; 30,500,00 ac-ft storage for maximum 9,500,000 ac-ft flood storage
- Curvature tightened from crest radius of 740 feet to 505 feet

Terrestrial photogrammetry

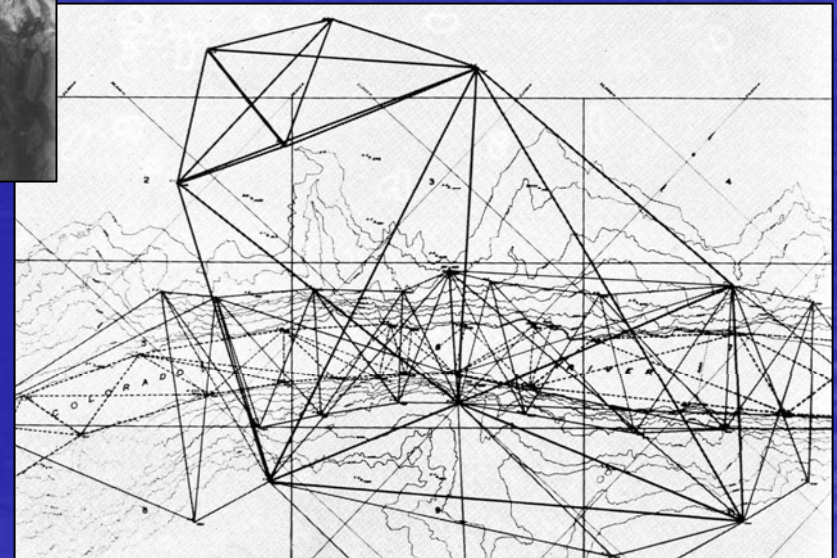
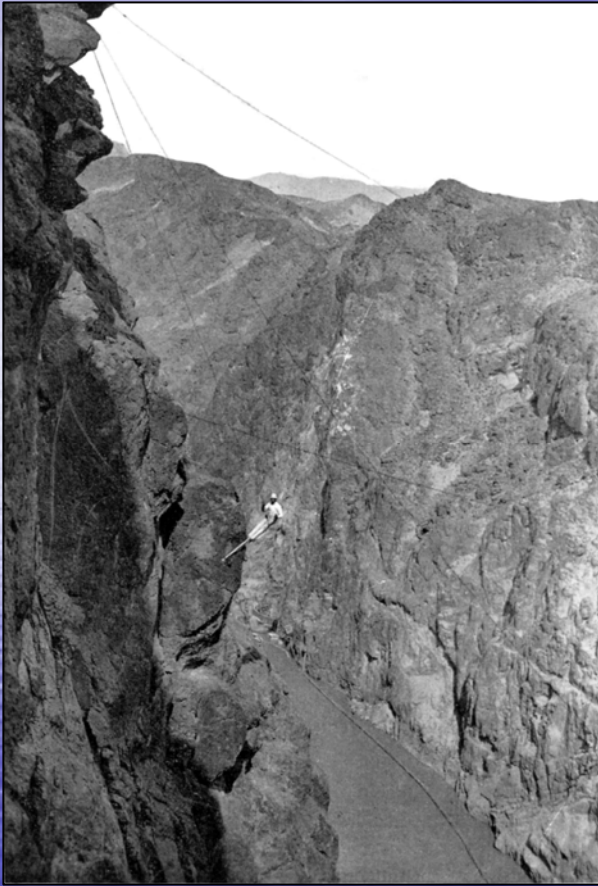

Making an accurate topographic map was a major obstacle before construction could begin.

The finished product

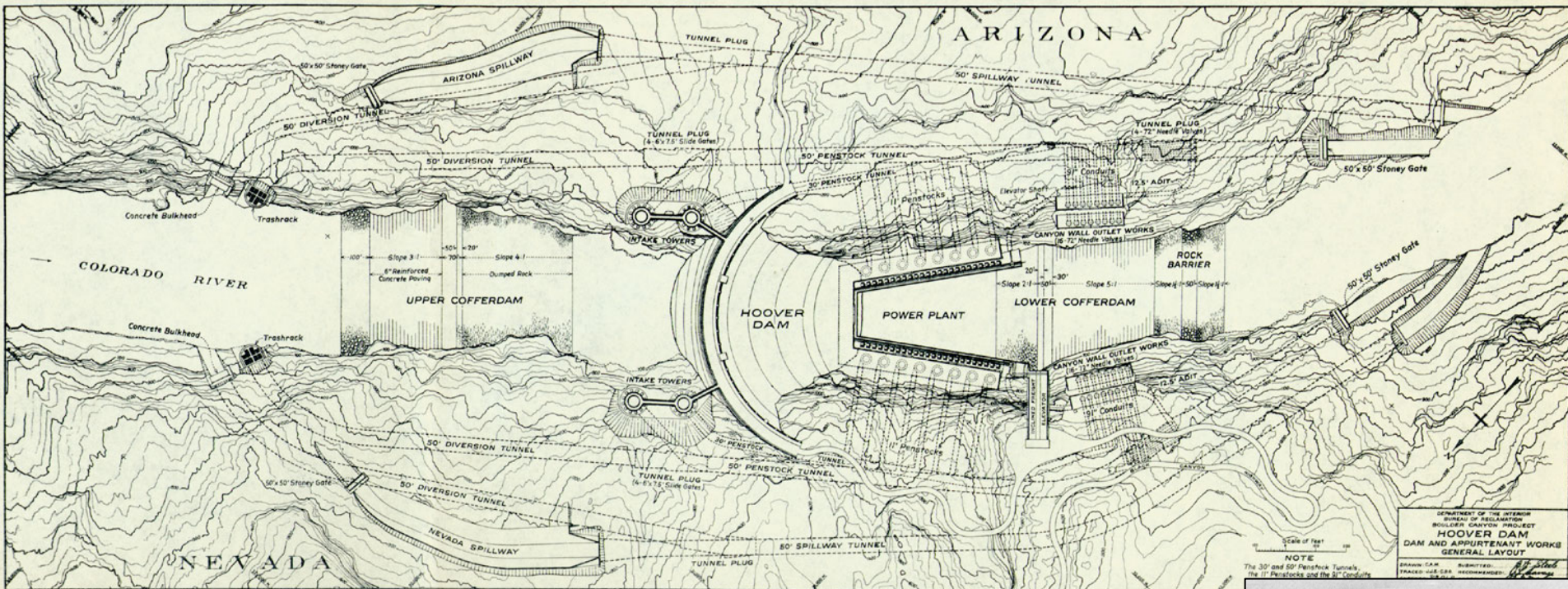

Terrestrial photogrammetry was employed using photo theodolites, directed by COL. Claude Birdseye of the U.S. Geological Survey (inset), who had led the mapping expeditions of the river channel through Grand Canyon in 1923.

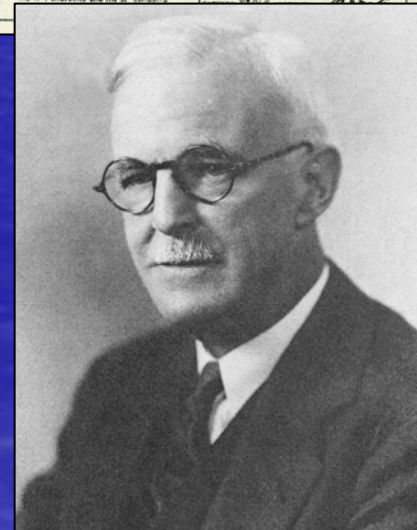

Boulder Canyon Project:

- With a budget of \$165 million, it would be the **largest federal contract ever awarded up to that time**
- It would require **more concrete** (4.5 mcy) than all previous Bureau of Reclamation projects combined (4.4 mcy)
- **No single contractor** was large enough to bid the job alone

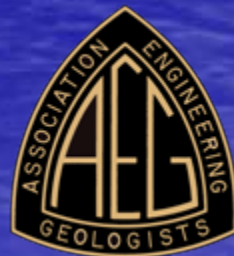

Government would provide:

- ALL MATERIALS, except concrete aggregate
- Railroad spur and highway to crest of gorge
- Construction of Boulder City, providing housing for 80% of workers
- Assumed flood damage liability after cofferdams accepted
- Government to **emplace turbines** and **machinery** for hydro powerhouses (cont'd till 1961)

The massive job was split into 5 Categories, with performance timelines:

- 1) River Division works – cofferdams and four 56 ft diameter tunnels
- 2) Concrete gravity arch dam
- 3) Side channel spillways and tunnel chutes
- 4) Outlet works and valve houses
- 5) U-shaped concrete power house



Six Companies Incorporated actually seven

- W. A. Bechtel and Henry J. Kaiser 30%
- Utah Construction Co. 20%
- MacDonald & Kahn Co. 20%
- Morrison-Knudsen Co. 10%
- J. F. Shea Co. 10%
- Pacific Bridge Co. 10%



Six Companies Board of
Directors visits the dam site

Frank Crowe and Walker R. Young

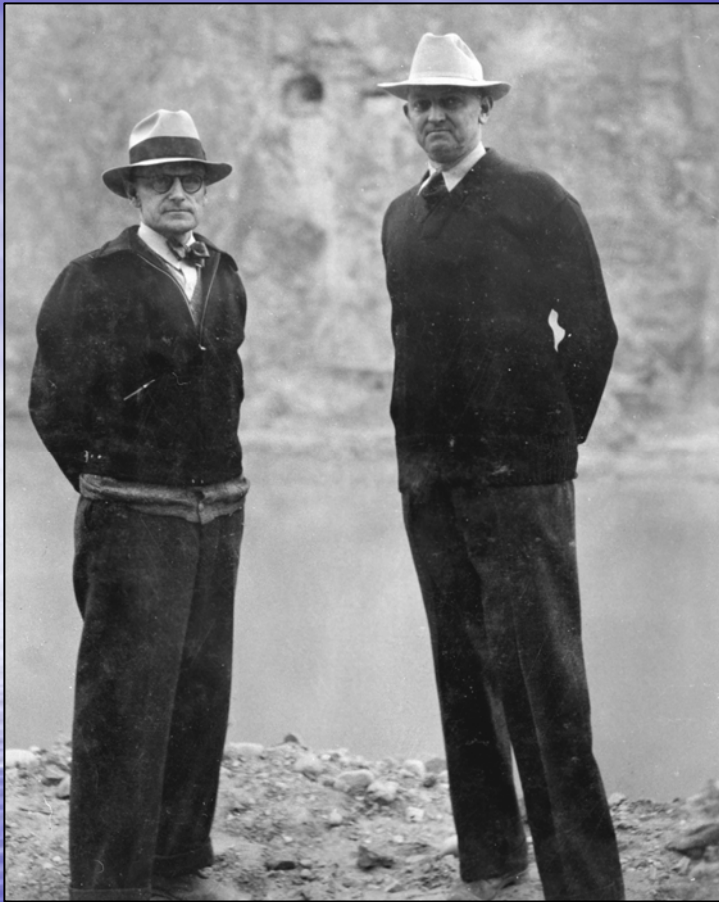

Everyone's choice for Construction Superintendent was **Frank Crowe**; a former BurRec engineer employed by Morrison-Knudsen. Crowe was 6'-6" tall. He is shown here with **Walker R. Young**, the Bureau's onsite Construction Manager.



Elwood Mead signs largest government contract in history with Six Companies, March 1931

Under-balanced bid

- Six Companies purposefully bid the rock excavation work high, at \$8.50 per yard, asking \$13,285,000 for 1,563,000 yds of tunnel excavation
- To compensate, Six Companies bid the concrete placement well below market price; at just \$2.70/yd: requesting \$9,180,000 for the dam's mass concrete and \$3,432,000 for lining the diversion tunnels

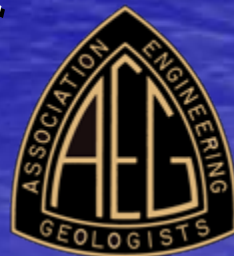

Site Access was the most difficult obstacle to overcome

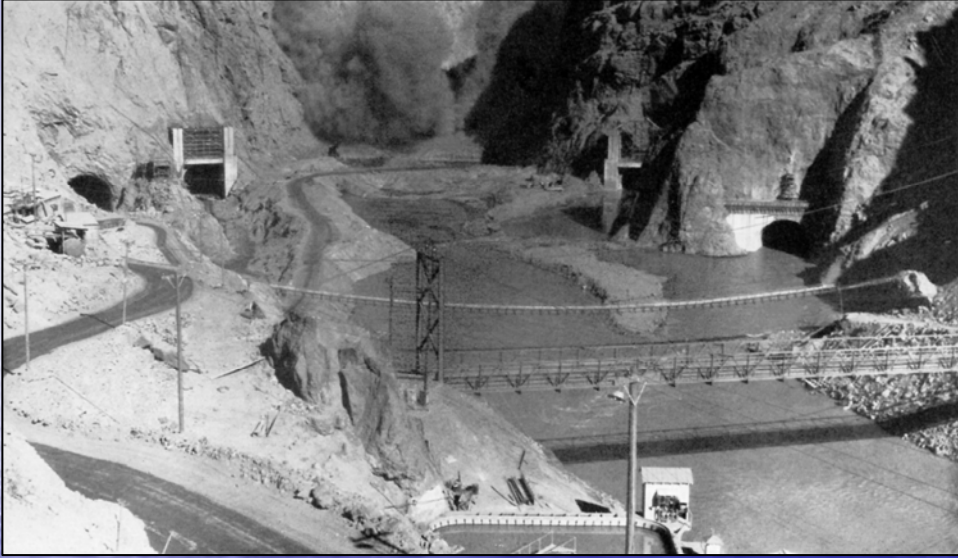

Ragtown – Summer 1931

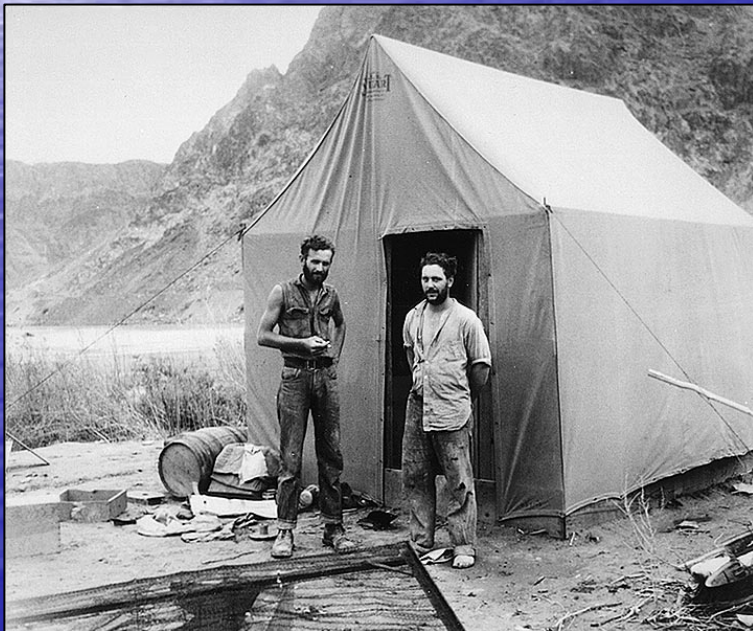
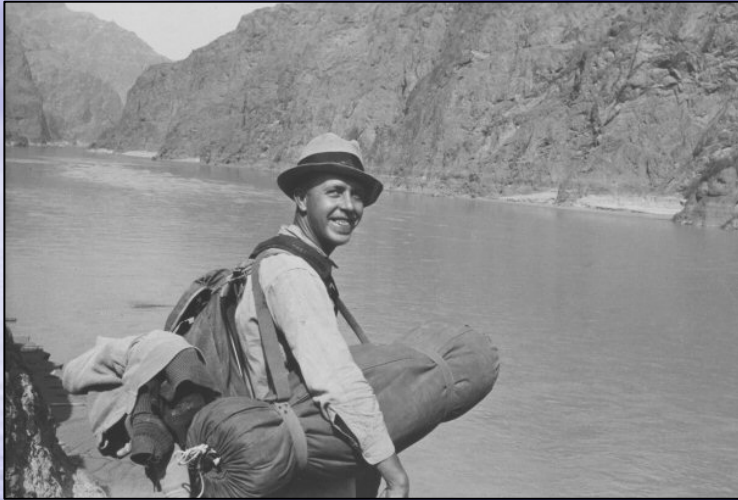

Several thousand workers and their families descended on the banks of the Colorado River in the spring and summer of 1931, hoping to find work.

Accommodating workers



21,000 men worked on the dam, with the average work force numbering **3,500 per month**, reaching a maximum of **5,218 in June 1934**. Average monthly payroll was \$500,000, disbursed on 10th and 25th of each month.

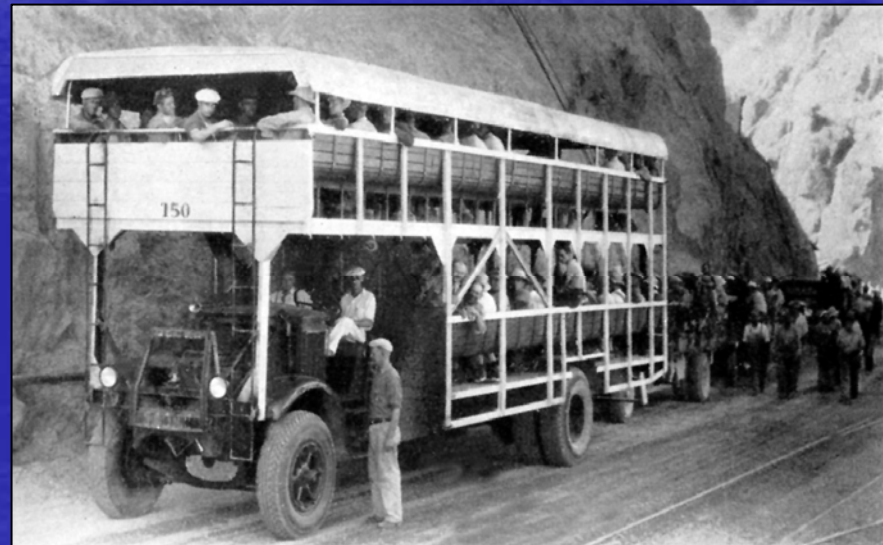

Boulder City - A model town owned by the Government

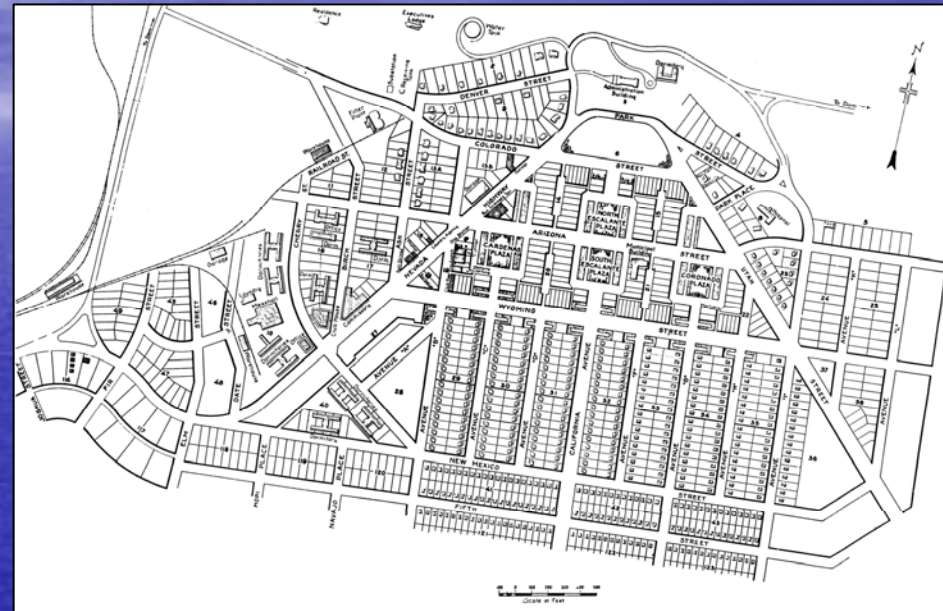
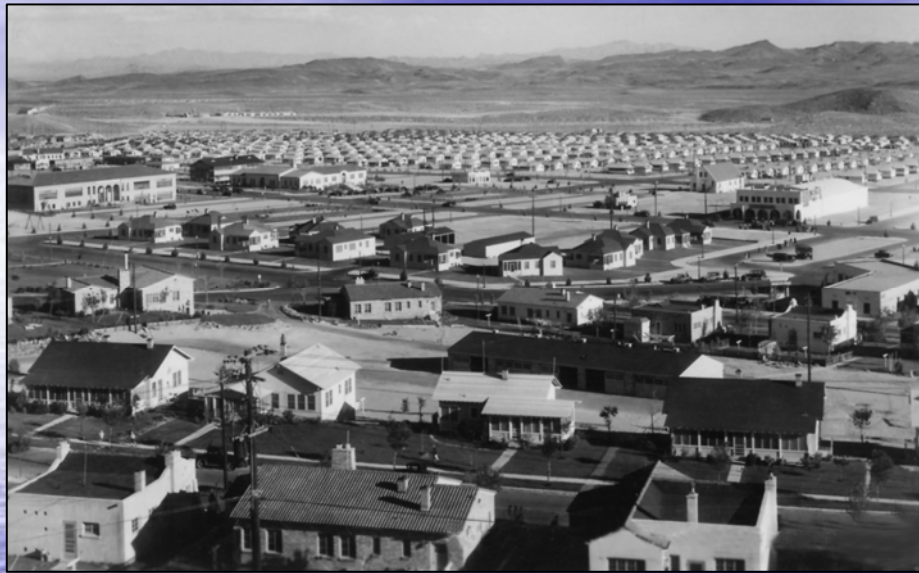

Boulder City was constructed by the Interior Department to house 5,000 workers and their families. No drinking or gambling allowed; remained a government town till 1961.

Largest Diversion Tunnels



At 56 feet in diameter and averaging 4,000 feet long; these were the largest diversion tunnels ever constructed at the time; under intense heat and air pollution. **Major obstacles were heat and air quality.** The contractor employed electric shovels inside the tunnels, but used gas-powered dump trucks.



Emergency room built on job site

Death Toll



Water carriers added late summer 1931

During July 1931 14 men died working in the overheated and under-ventilated tunnels; necessitating changes in safety precautions. The official death toll for the entire job was 96; the unofficial total was 112.

Staged Excavations

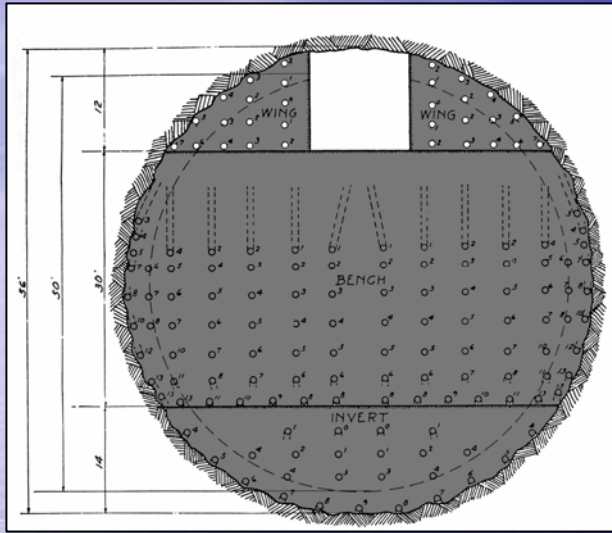

Pilot bore in tunnel crown



World's first drilling jumbo

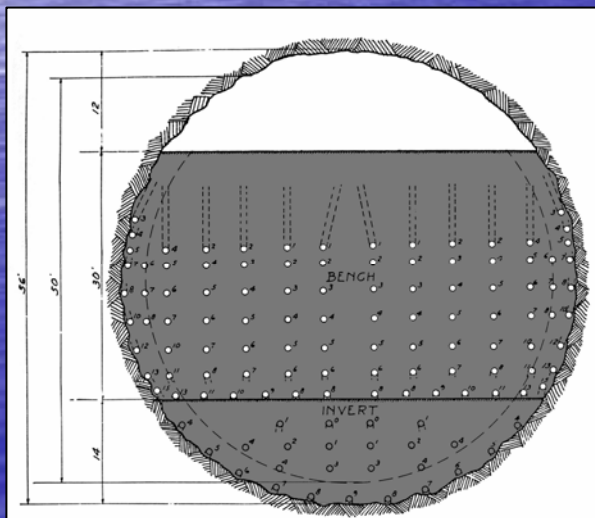

Jumbo drilled holes shown in white

Frank Crowe was masterful in appreciating **critical path management**. The biggest challenge was completing the four diversion tunnels by May 1, 1934, before the spring runoff arrived.

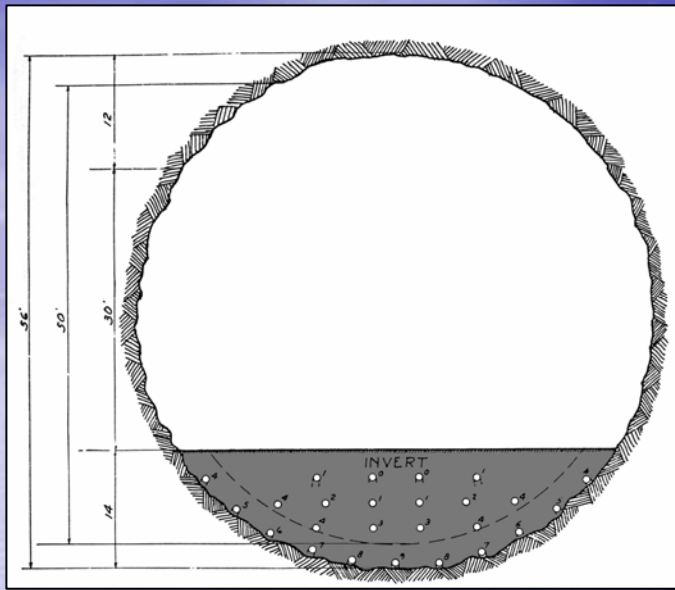

Tunnel Invert excavated last

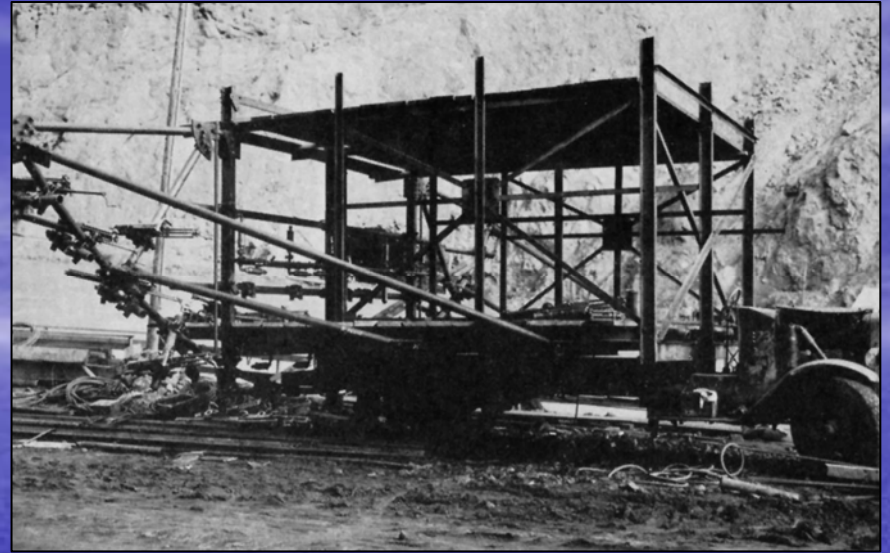

Invert drilling jumbo



Finished 56 foot diameter bore



Ready for lining

Concrete tunnel lining



The tunnel was lined with 3 feet of reinforced concrete, requiring 312,000 cubic yards. Lining of the four diversion tunnels cost \$3,432,000.



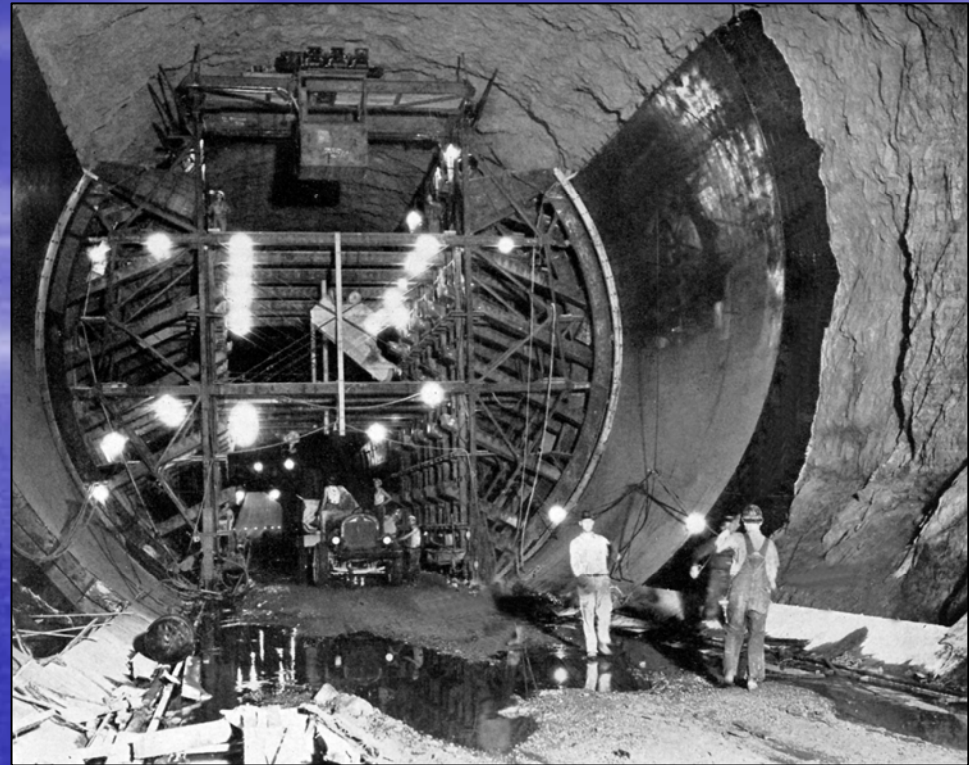

The contractor employed steel slip forms, using diesel fuel as a form bond breaker. The most difficult pour was the crown, across the top of the tunnel.

Advantage of an under balanced contract: cash up front

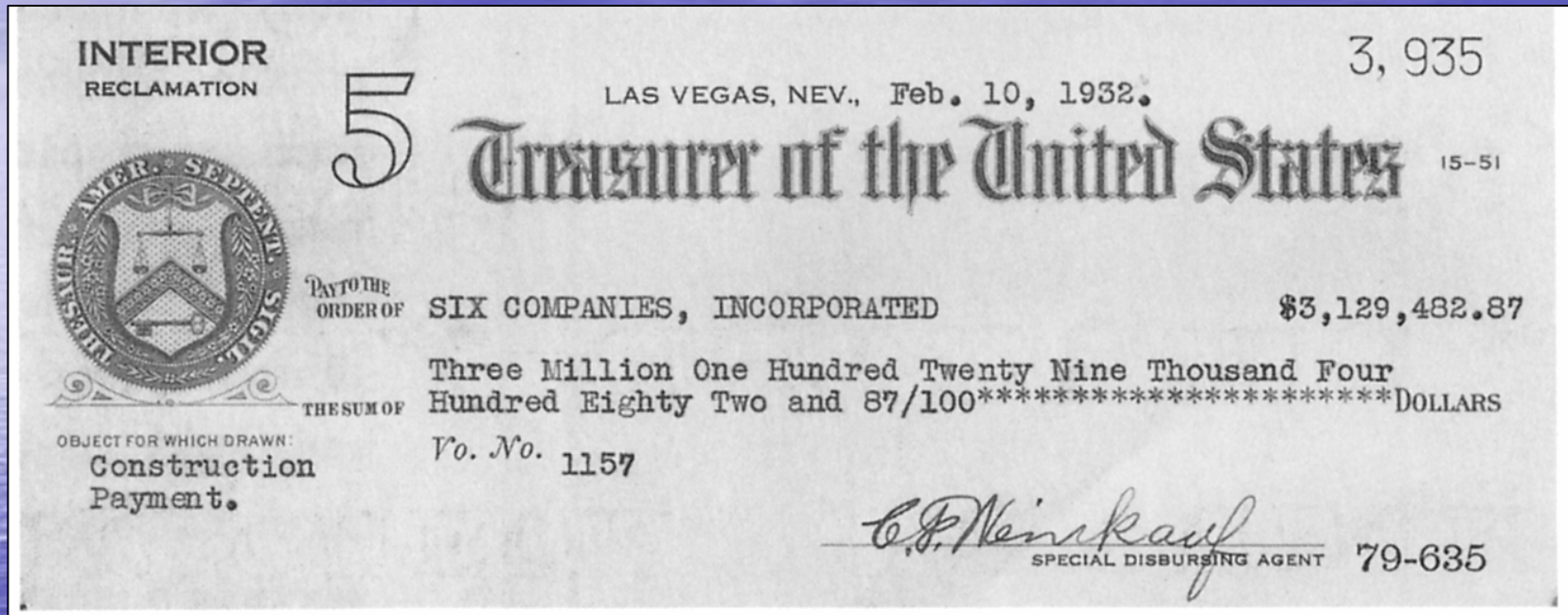

- The excavation of the four diversion tunnels cost \$13,285,000, 27% of the project cost. The concrete lining cost another \$3,432,000. This provided a great deal of cash income up front, to balance out the \$5 million performance surety ponied up by the partners at the job's outset.

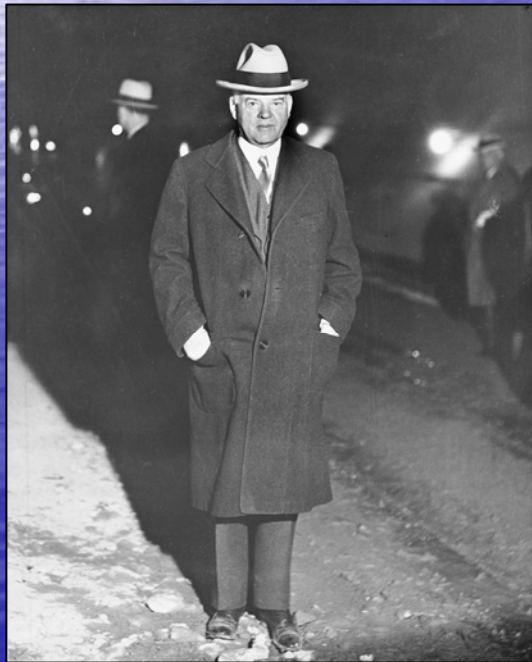
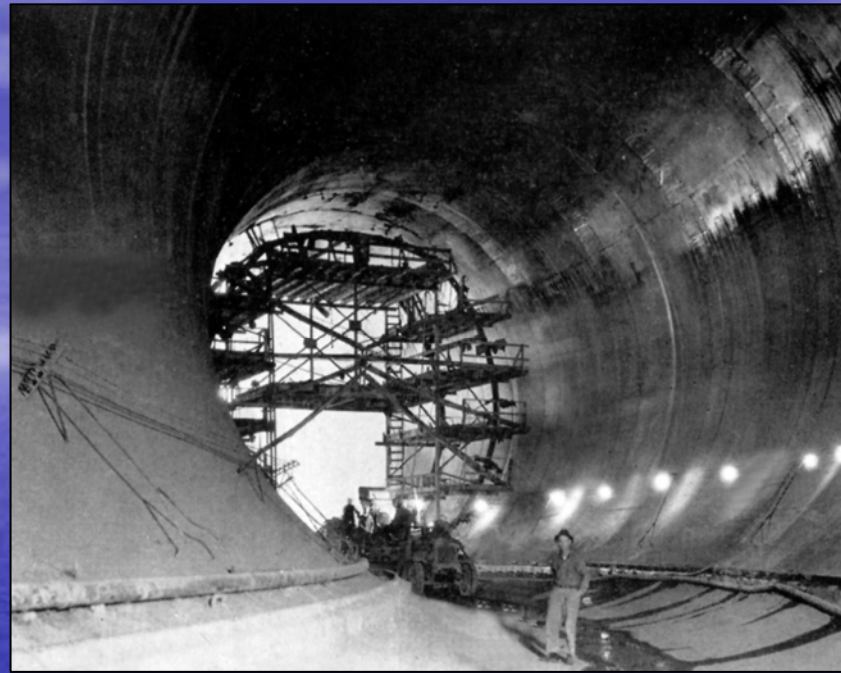
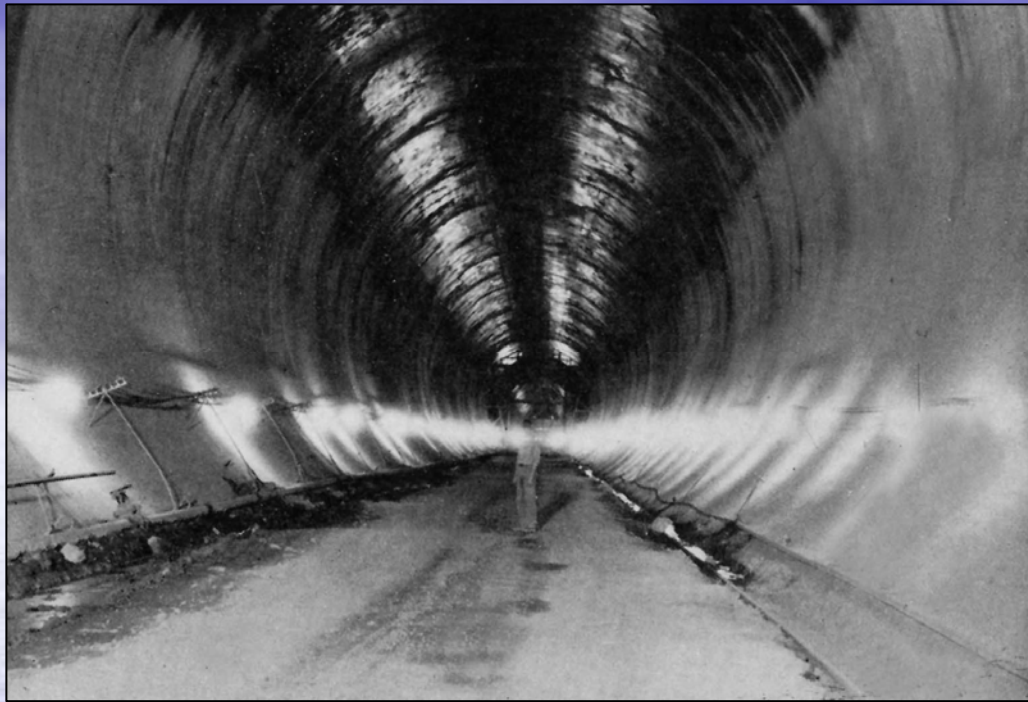

After lining, the invert section was temporarily backfilled with a gravel bed to provide vehicular access until the tunnels were filled with water.

View at left shows President Hoover walking through one of the Nevada diversion tunnels during his only site visit, in December 1932

River flow was diverted through Tunnel No. 4 on Nov. 14, 1932; 1.5 years ahead of schedule. This virtually guaranteed a profitable job

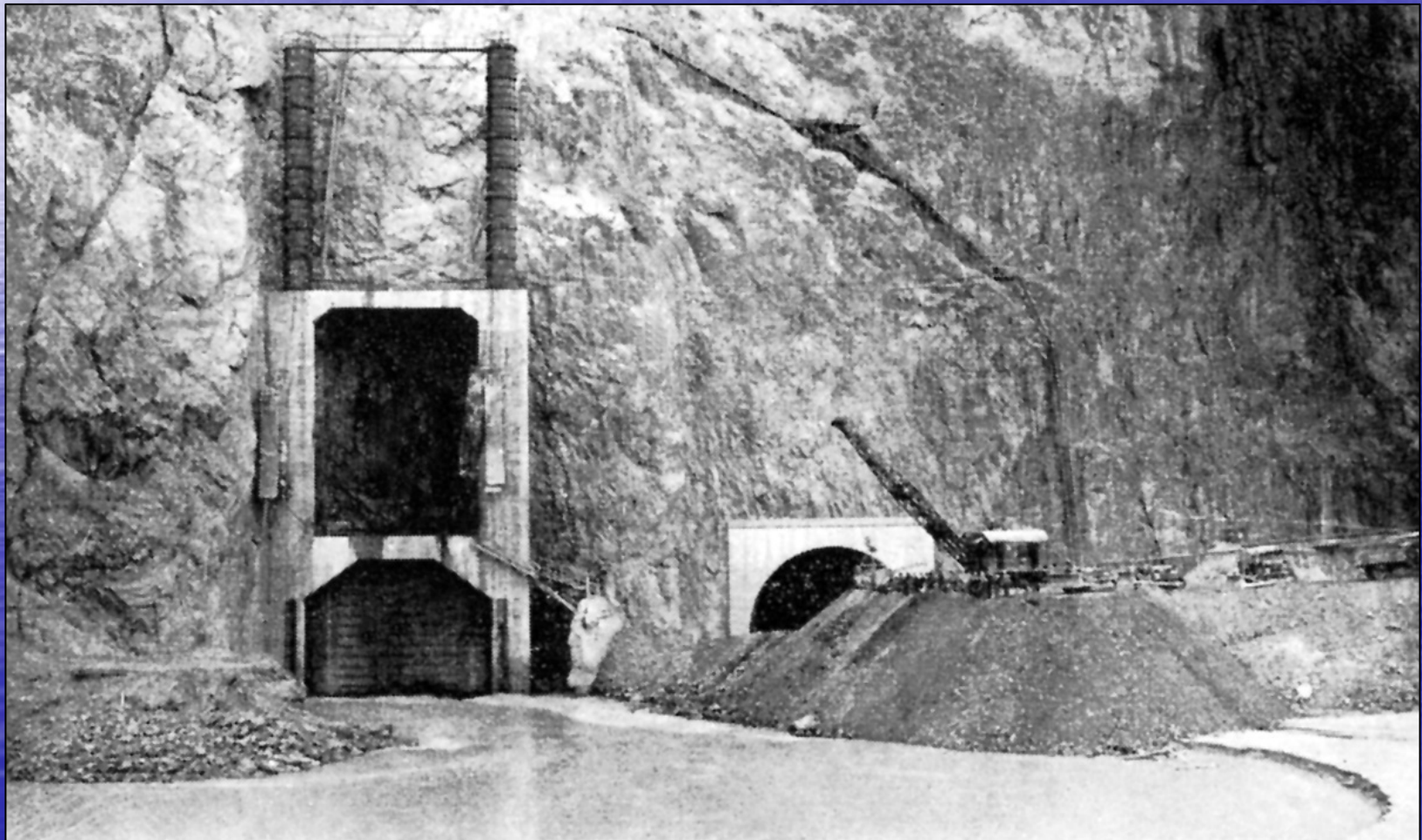

Diversion tunnels

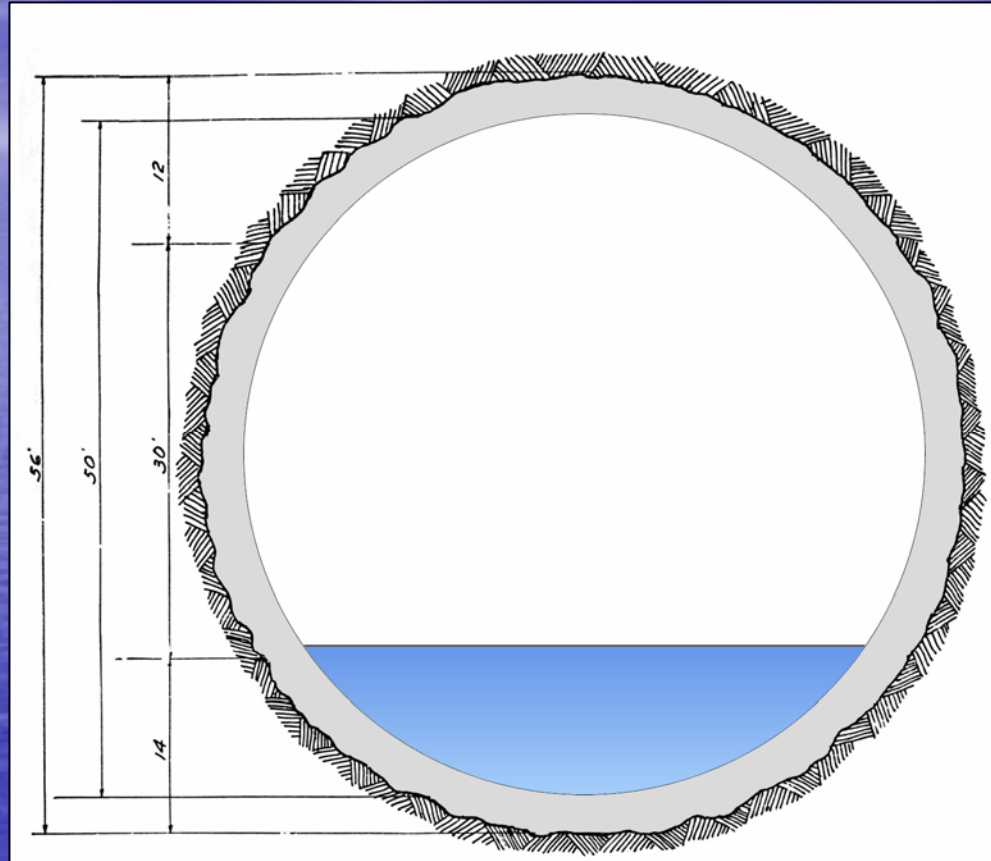

- The spring flood of the Colorado River averaged 120,000 cfs every 2-1/2 years, generally peaking in late May to late June. Prior to construction, great concern was expressed about the job site being flooded and wrecked.

Diversion tunnels

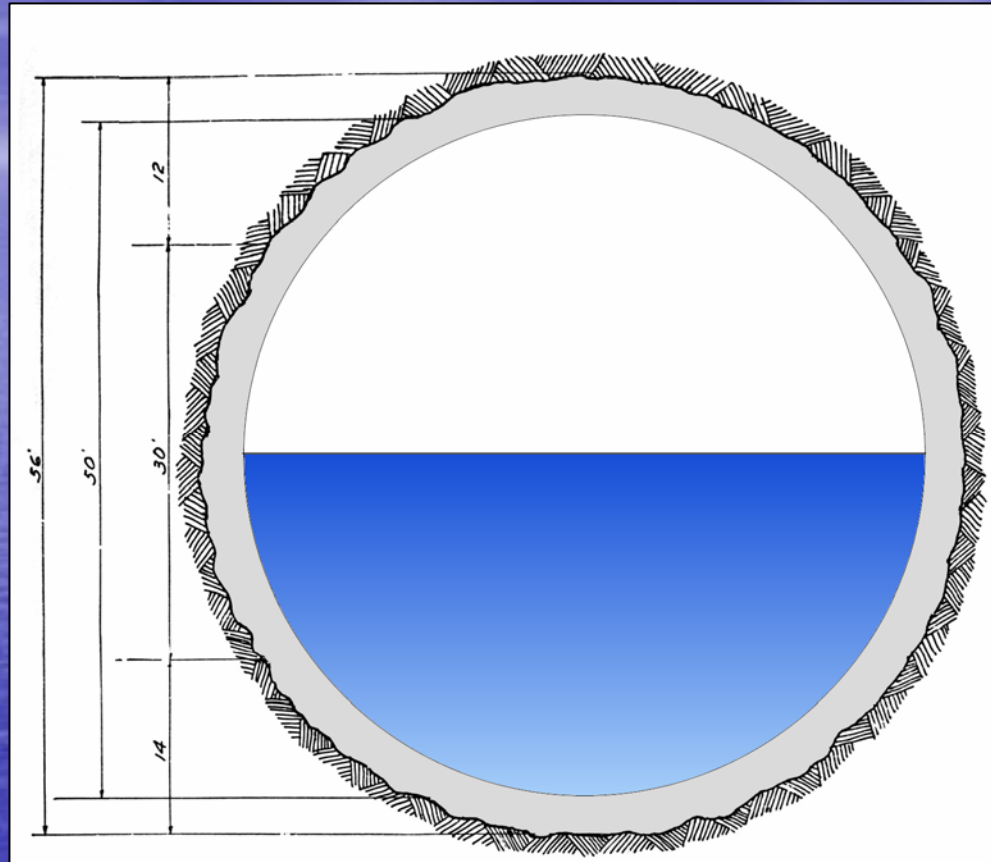

- The four diversion Each diversion tunnel was designed to convey 50,000 cubic feet of water per second (cfs); for an aggregate total of 200,000 cfs during construction.

Diversion tunnels

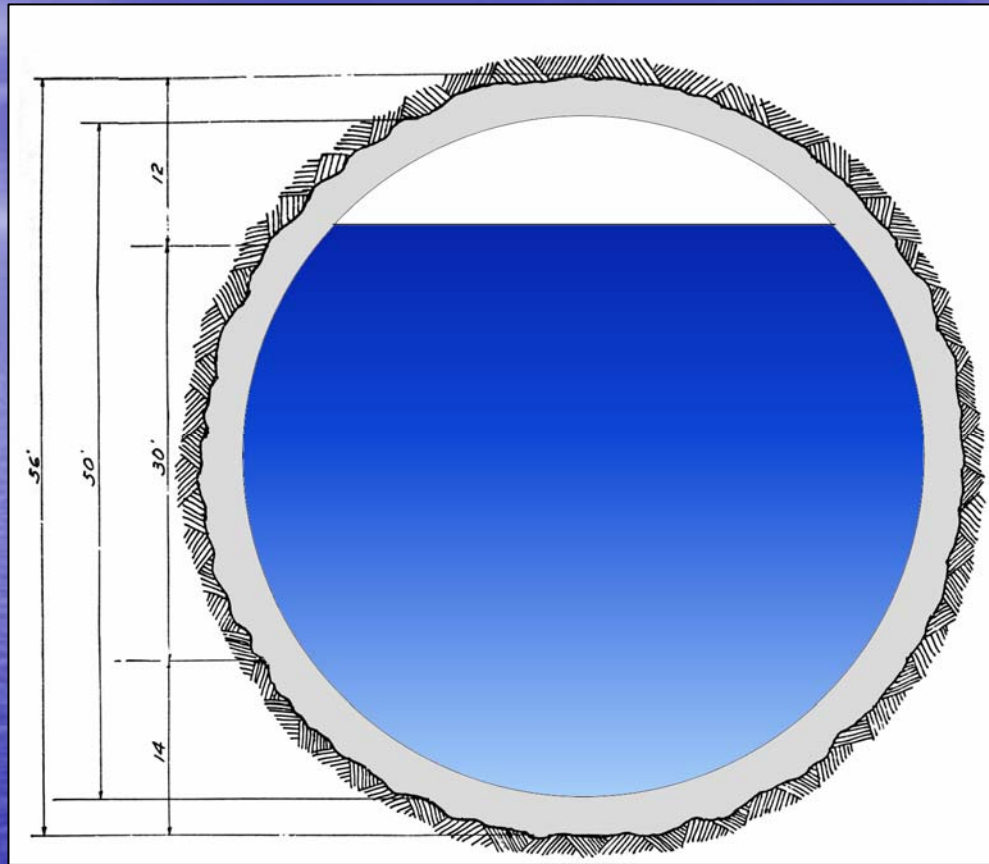

- A **flash flood** inundated the construction site on February 10-11, 1932, before any of the diversion tunnels were completed. The shutdown and clean-up lasted 5 days. The **biggest flow** the tunnels had to handle during construction occurred on June 16, 1933 when 73,000 cfs was safely conveyed around the dam site, while the **minimum flow** of 1,000 cfs was recorded on August 26, 1934.

Cofferdams

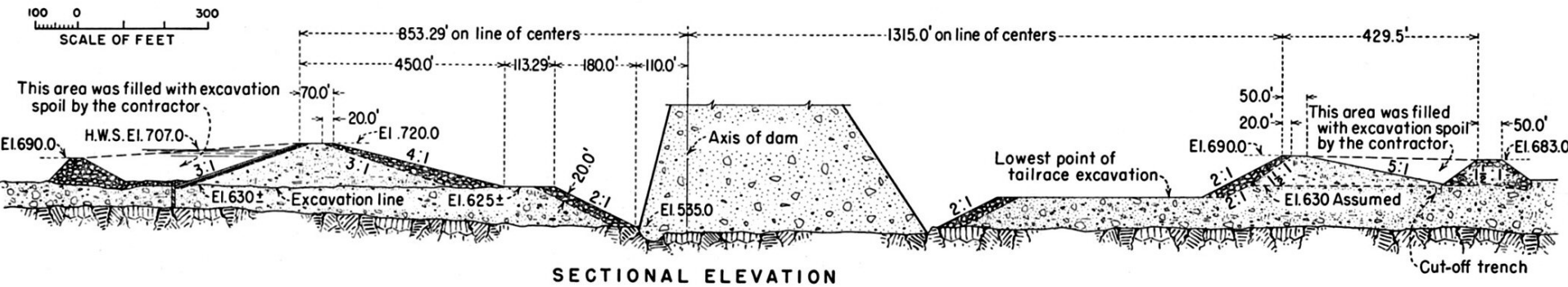
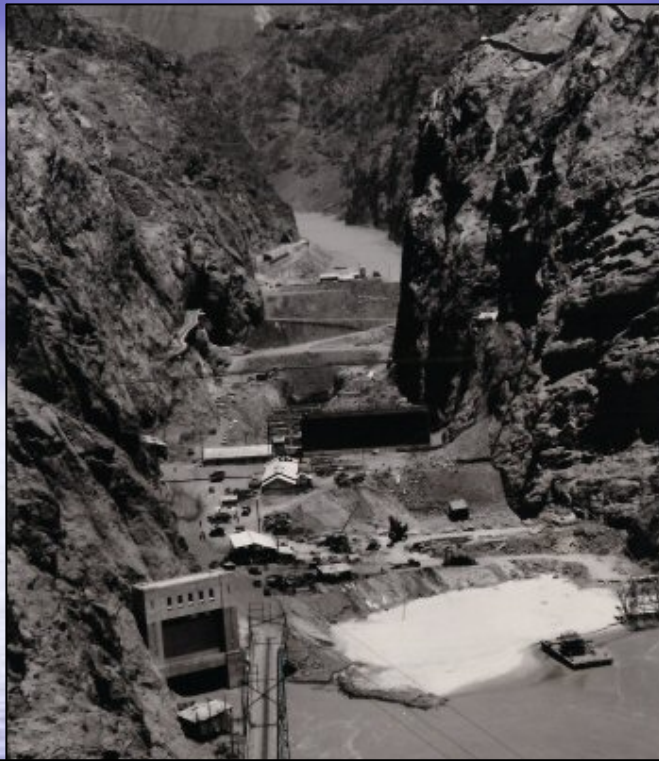

The 100 foot high cofferdams required 732,000 cubic yards in the upstream dike and 500,000 yards in the downstream embankment.

Lots of Surprises



A total of 6 million yards of material was excavated at the dam site.

A sawn 2 x 6 plank was found in the river bed buried 50 feet beneath the low water surface. Geologists suggested that it was deposited from a debris flow in Callville Wash during the high water of 1922.

Cleaning out the inner gorge

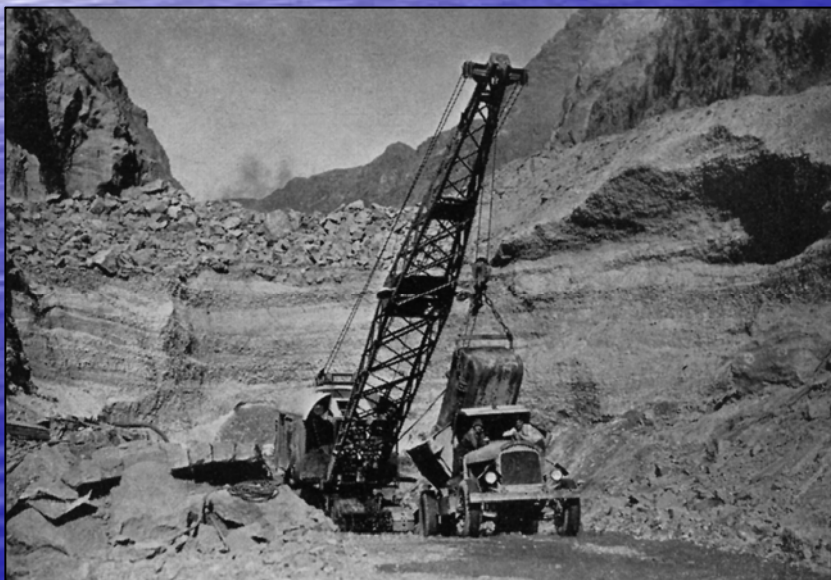
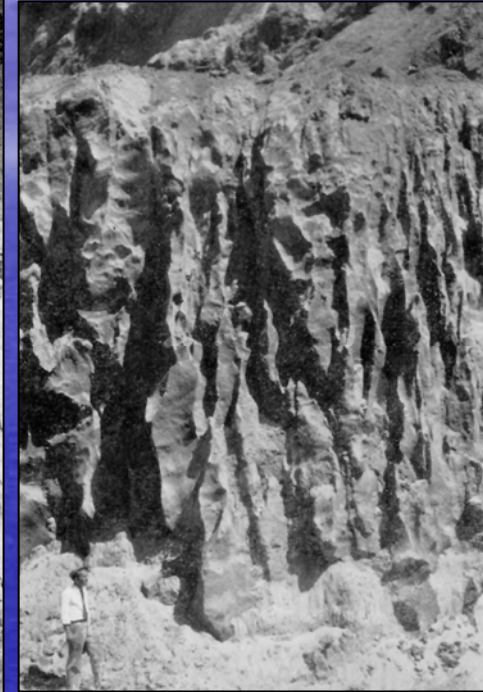

About 2 million cubic yards of material was excavated out of the river channel beneath the dam, revealing an incised inner gorge with fluting and boulders up to 12 feet across.

First concrete poured on June 6, 1933, 1.5 years ahead of schedule



Most of the mass concrete was placed using 8 cubic yard hopper buckets, delivered via the overhead cableways. Each bucket carried 16.5 tons of concrete.

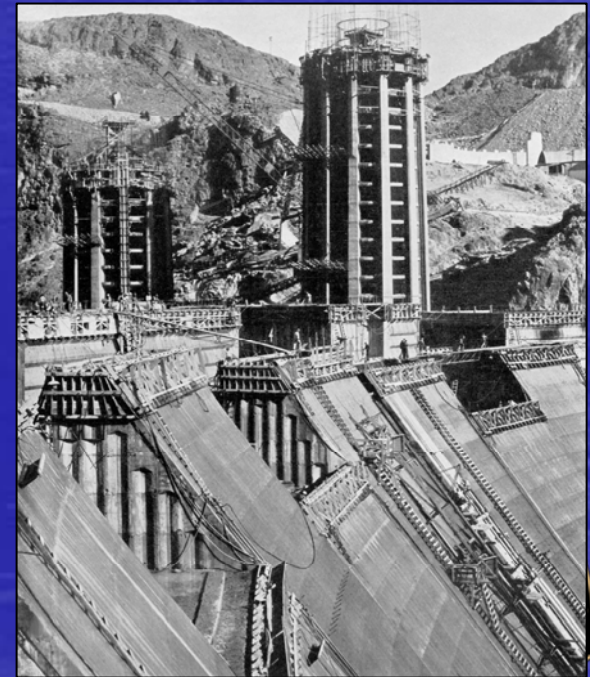
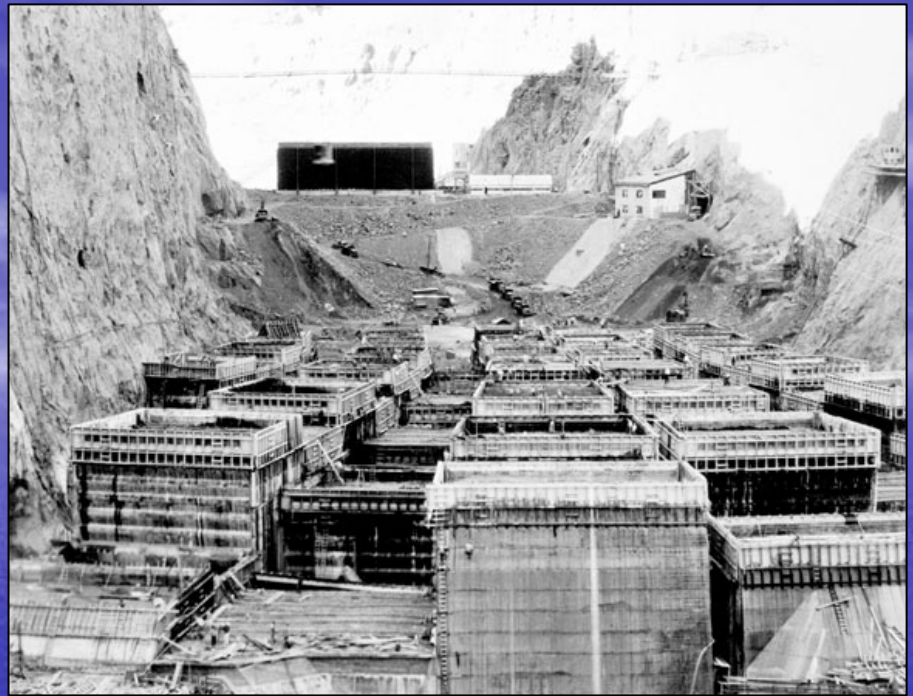
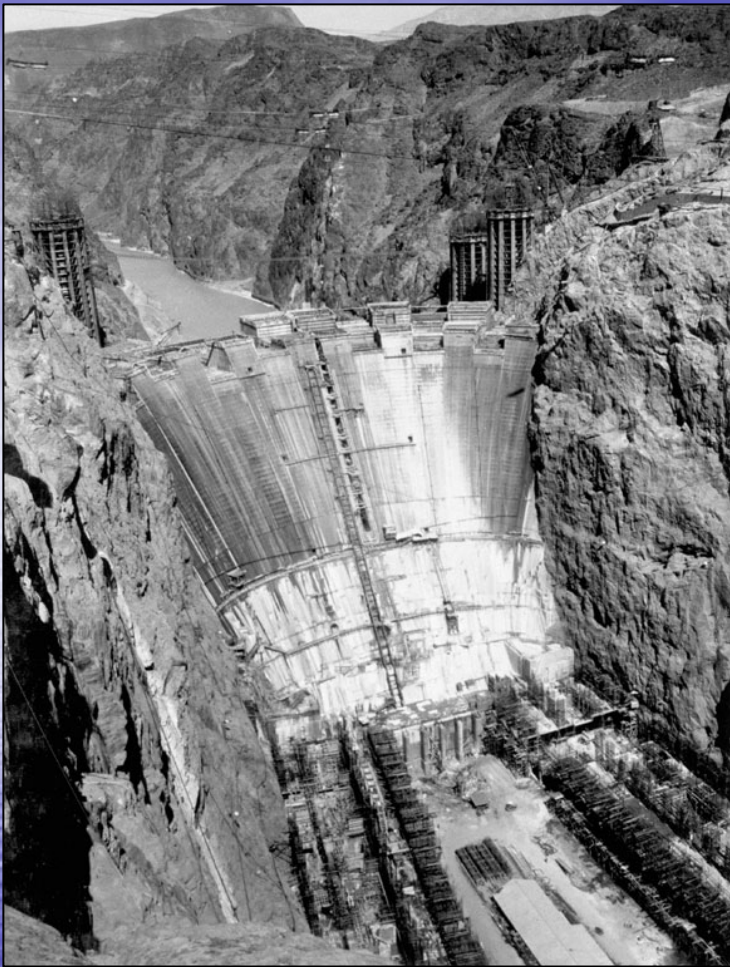

The dam required 3.25 of the project's 4.36 million cubic yards of mass concrete, at a cost of \$9,180,000. This was placed between June 6, 1933 and May 29, 1935; 2-1/2 years before the contract required completion.

Cableway scheme

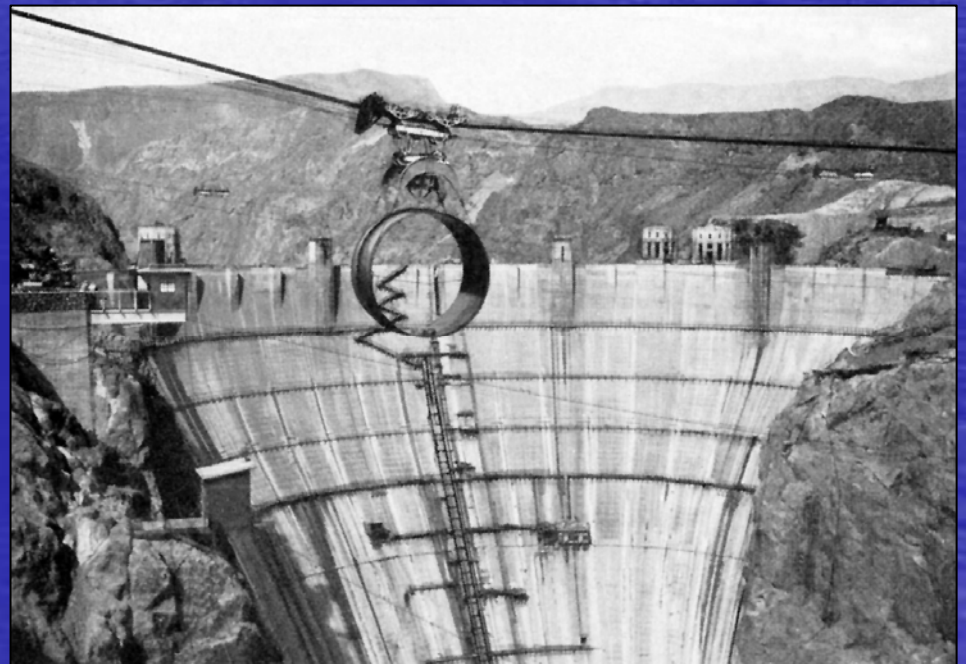
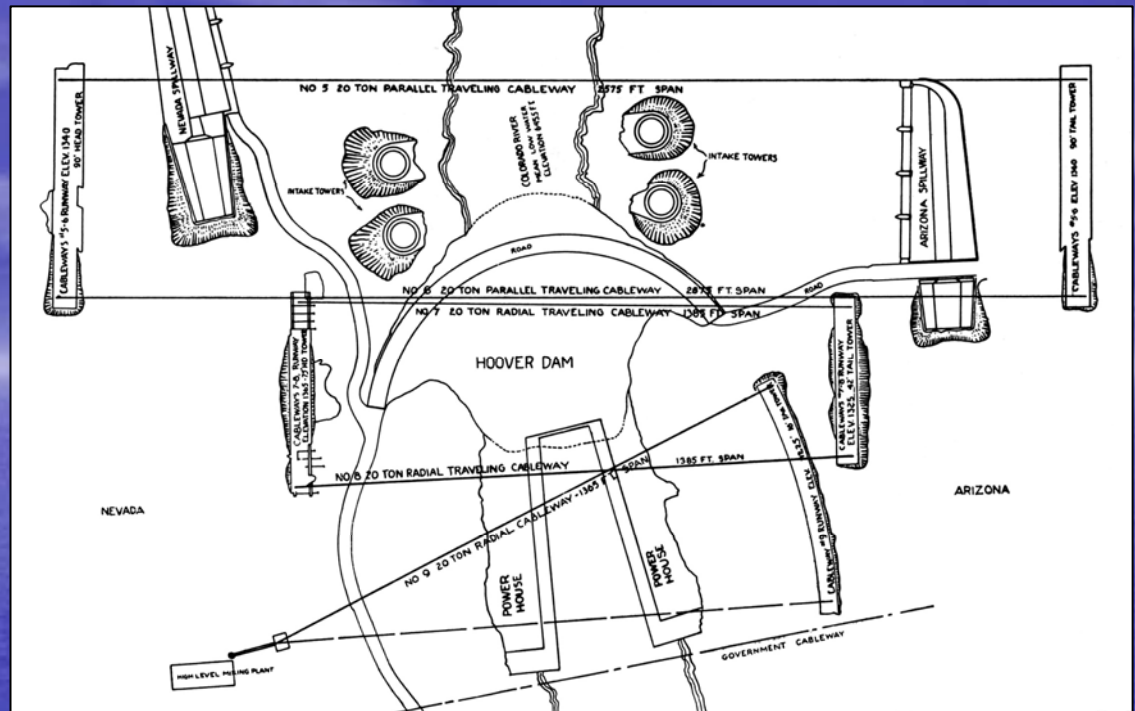

Cableways

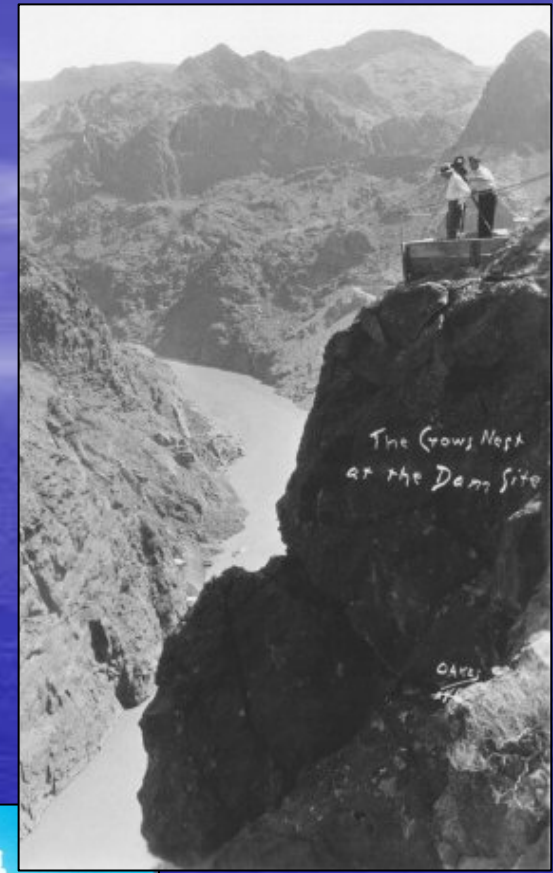

Crow's Nest

Permanent 150 ton cableway

Gravel and sand for concrete only material items not supplied by government



Aggregate came from a site 6 miles upstream of Black Canyon on Arizona side. Aggregate up to 9 inches in diameter was used in concrete.

Aggregate Plant

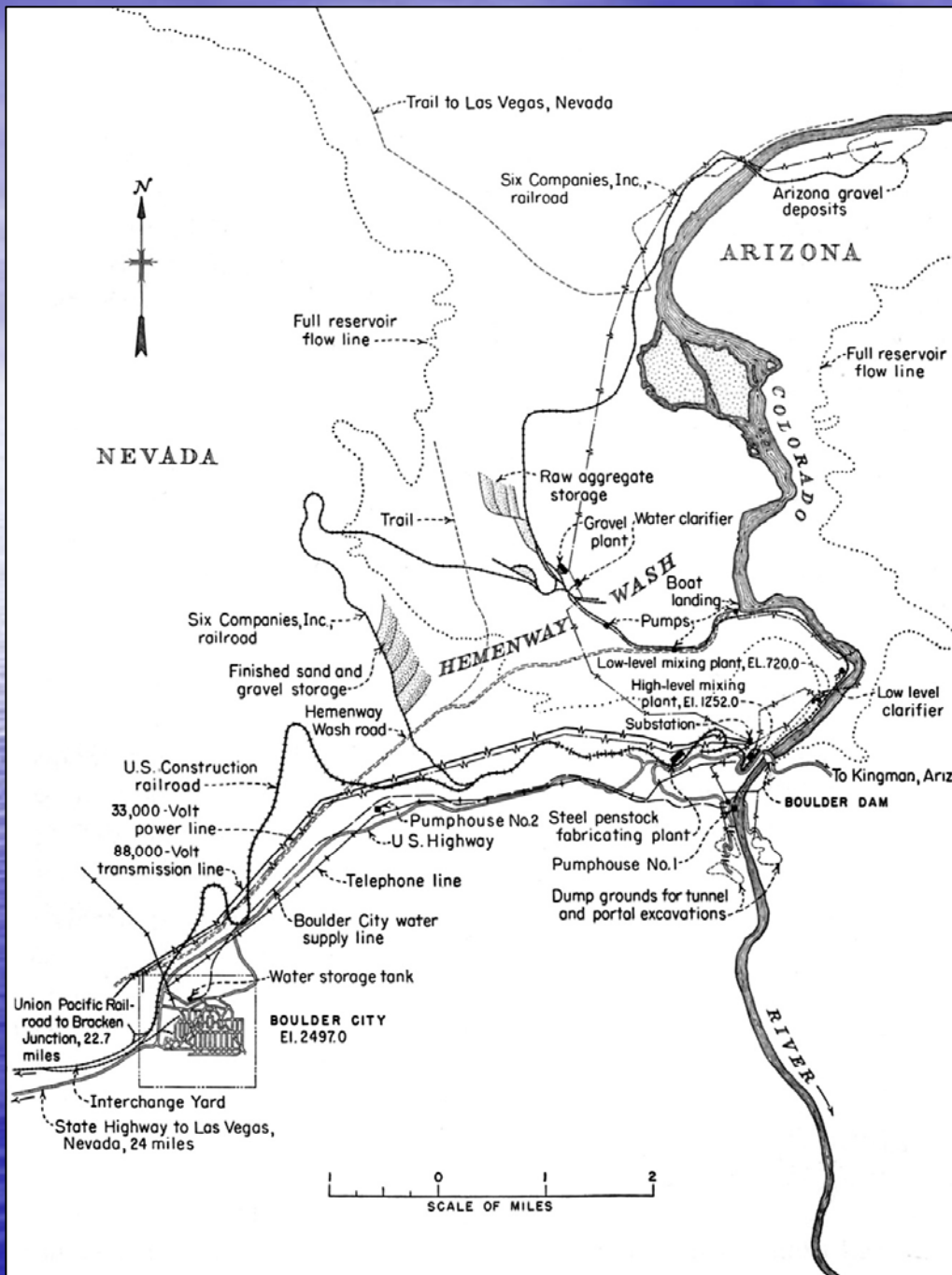

- A aggregate washing, classification and storage plant was constructed in Hemenway Wash

High and Low Concrete Batch Plants



Low Mix Plant



High Mix Plant

Frank Crowe's reputation was built on efficiency and innovation. His concept of using low level and high level concrete batch plants simultaneously doubled the rate of concrete placement where it was needed the most, below elevation 600, where the dam was widest. He picked up another year on the construction schedule, bringing the job to completion two years early.

First Use of Hard Hats

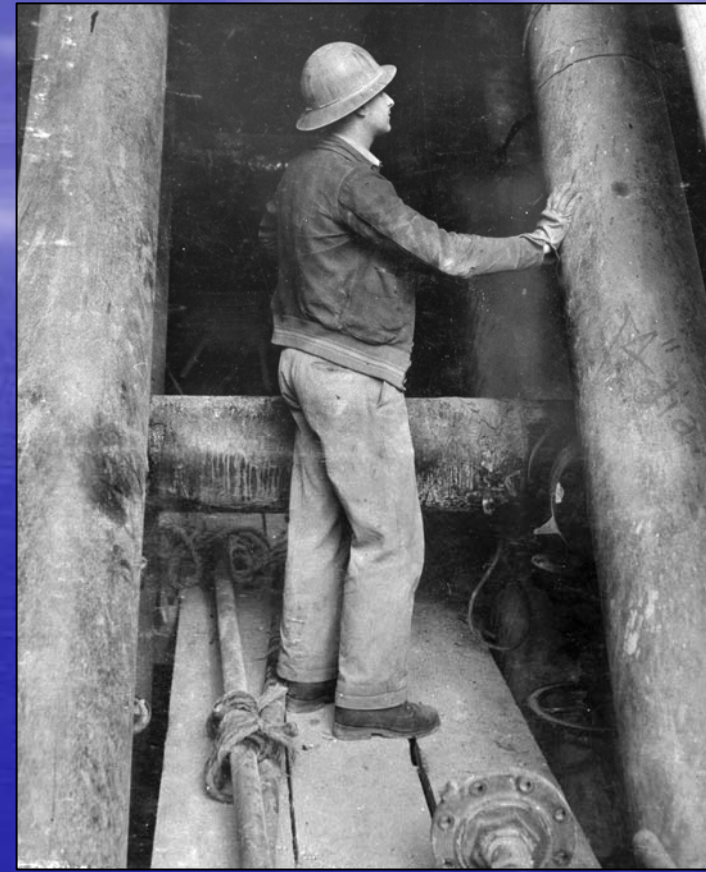

A number of workmen began fashioning their own safety hats by overlapping two baseball caps and dipping them in light tar to create a hardened shell for protection from falling debris (left image). Six Companies eventually began supplying workmen with fiberglass helmets, like those shown at middle and right.



- Hoover Dam was the first **round-the-clock** federal public works project, using three shifts per day, seven days a week.

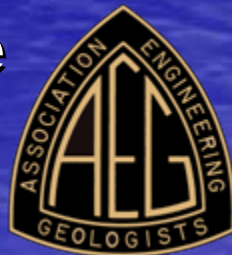

First Use of External Board of Consulting Engineers

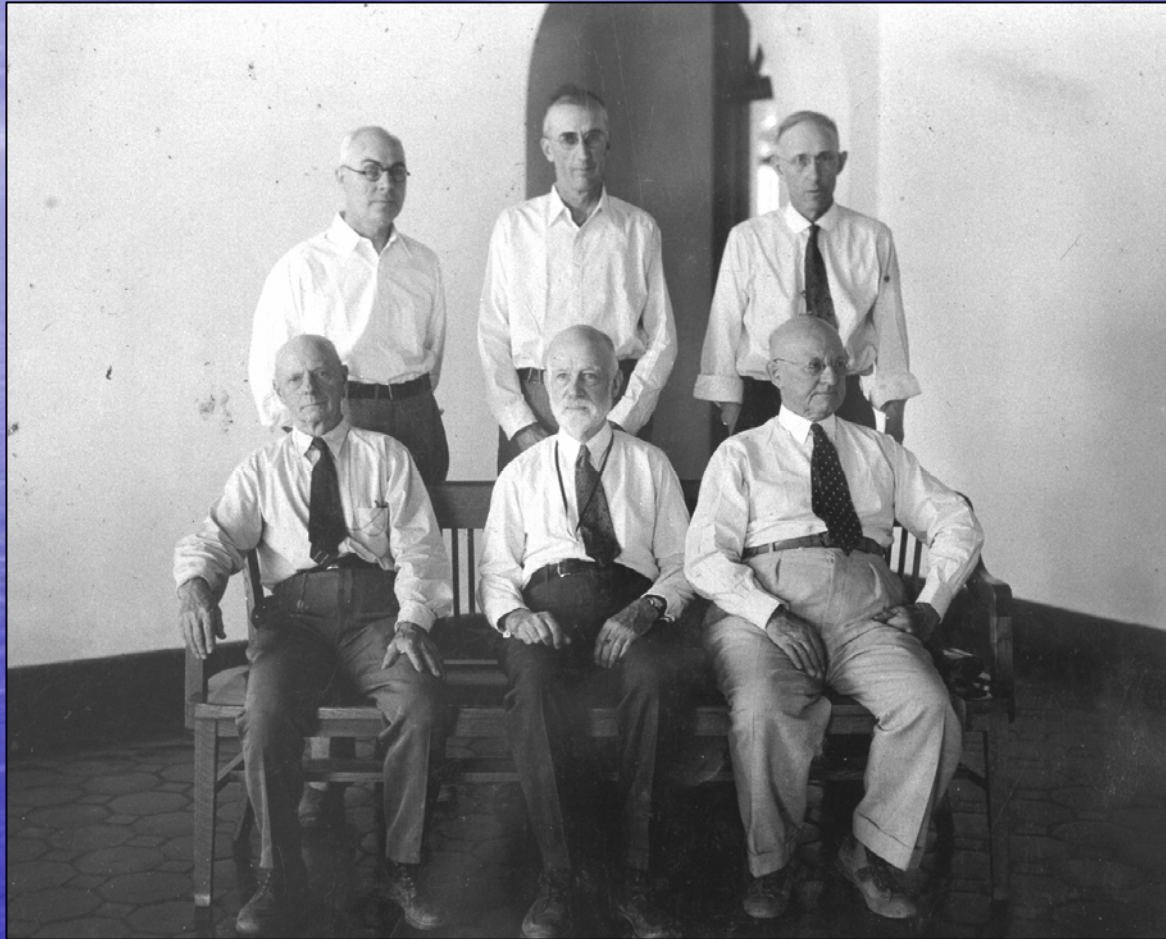

- Standing: BurRec engineers Jack Savage, Sydney O. Harper, B. W. Steele; Sitting: Consulting engineers D. C. Henny, W. F. Durand, and Louis C. Hill (September 1, 1933)

First Use of Embedded Instrumentation

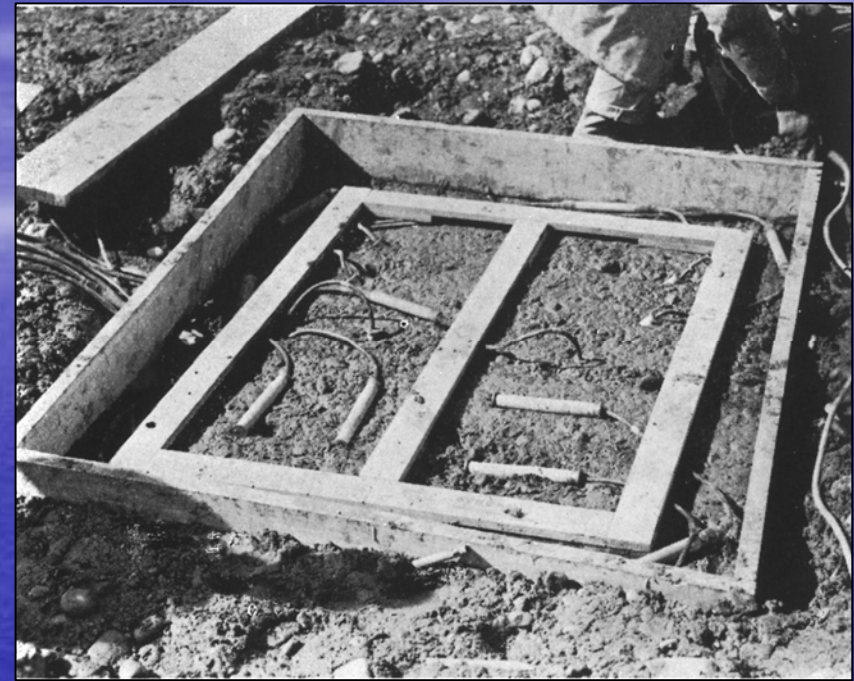

Carlson Stress meters and strain meters were embedded in the dam's mass concrete at various locations to record loads and strains as water rose against the dam.

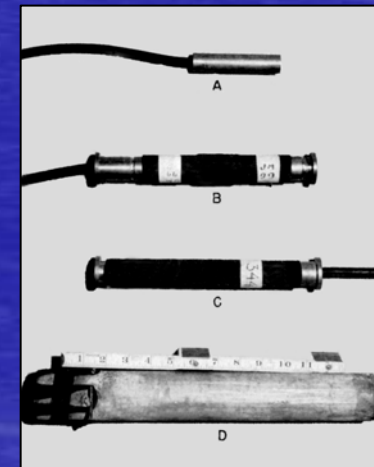
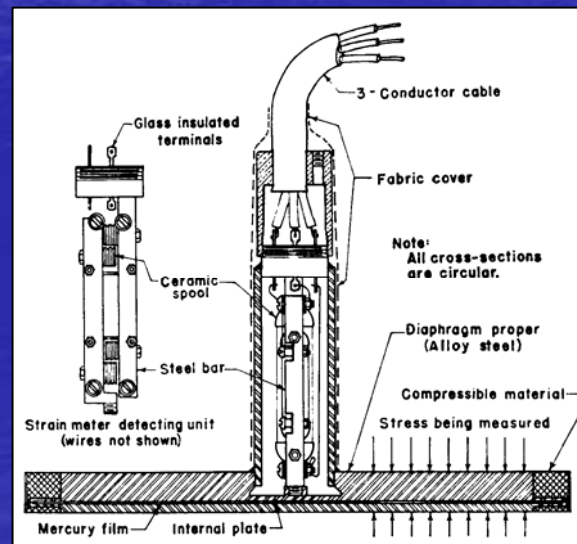

Unprecedented Stress Analyses

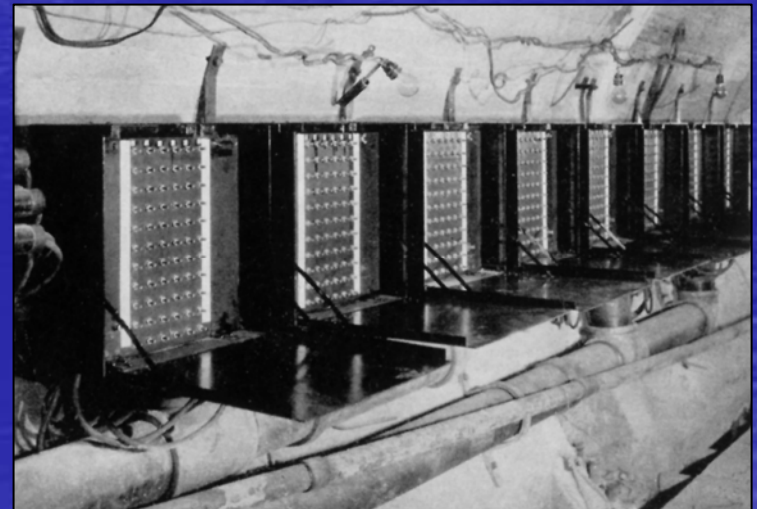
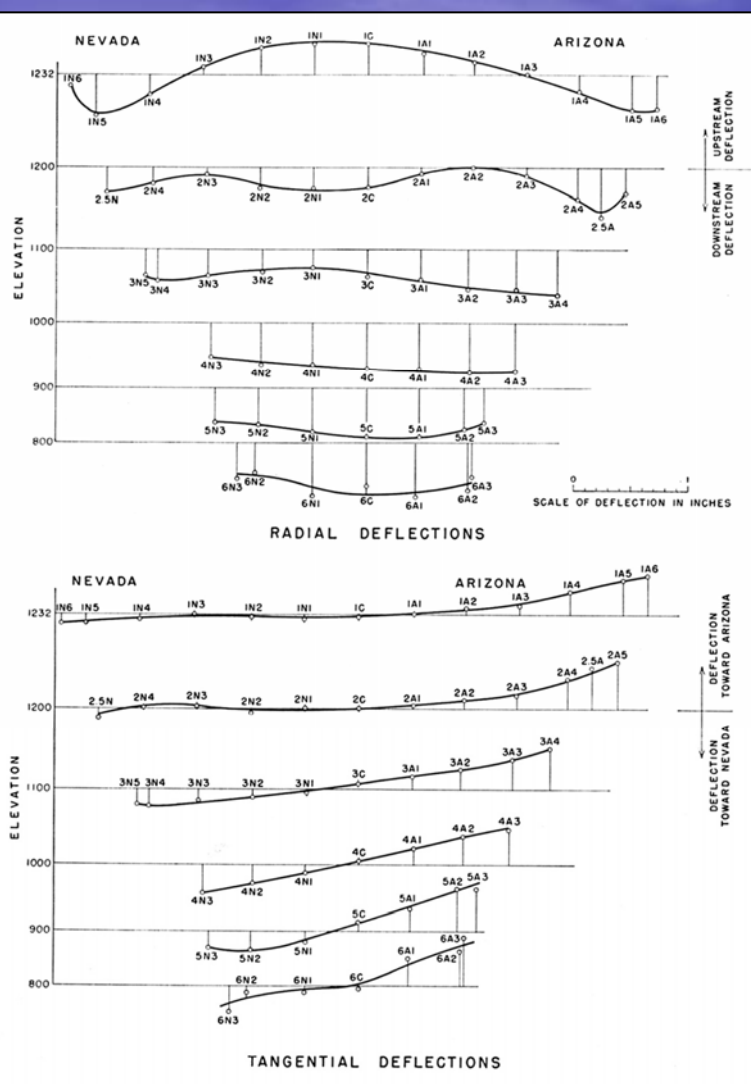

The structural performance data allowed validation of the Trial Load Analysis theory that had been developed in the late 1920s for arch dams.

First Use of Aggregate chilling and Cooling of Mass Concrete

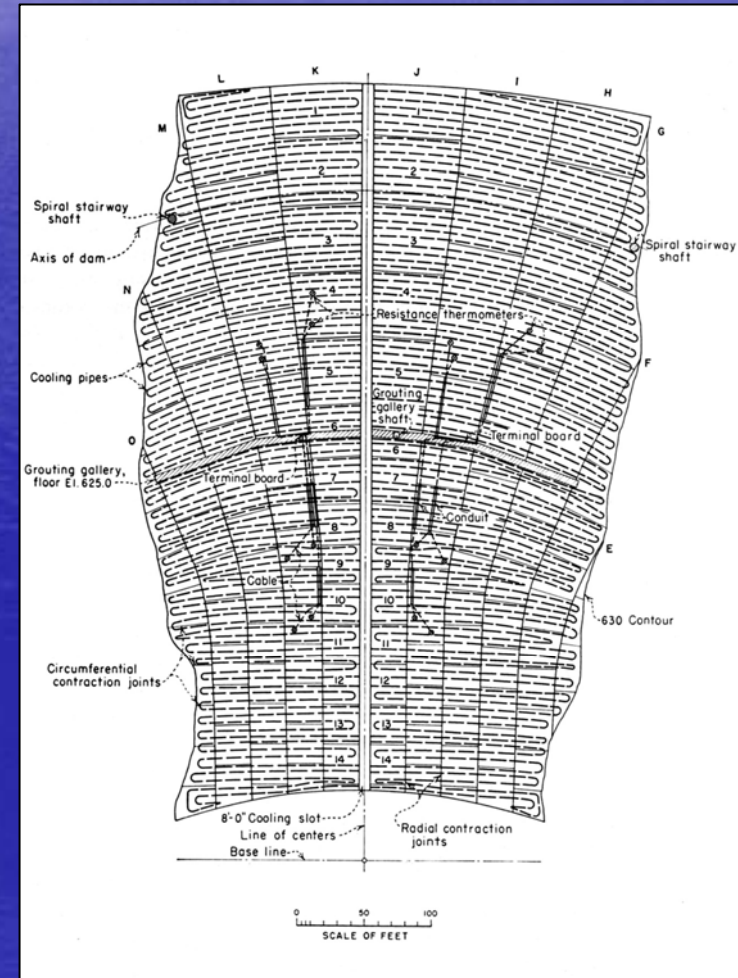
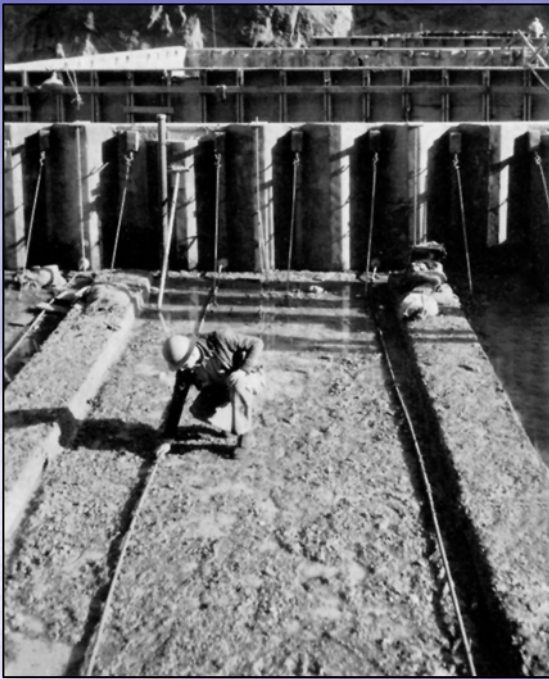

The "Big Slot"

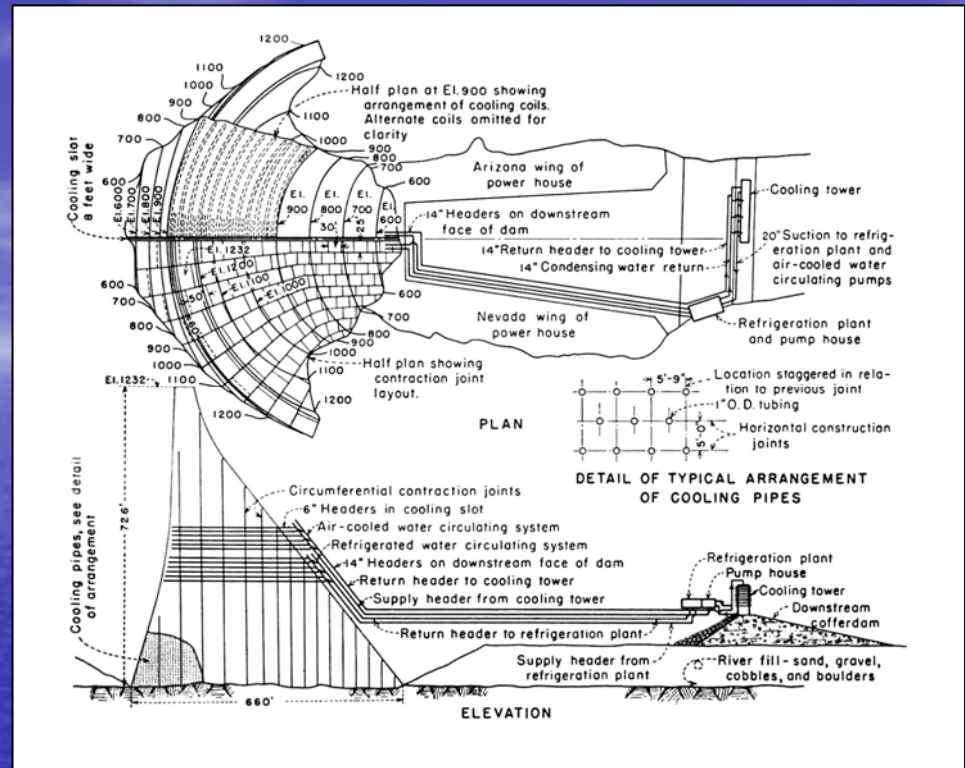

An 8-ft wide slot was left in dam axis to allow access to cooling pipes. River water was run thru the cooling pipes first, then water chilled to 42 F. This cool water removed the concrete heat of hydration, generated by chemical action as the concrete sets. Without artificial cooling the dam would have heated 40 F and taken 125 years to cure.

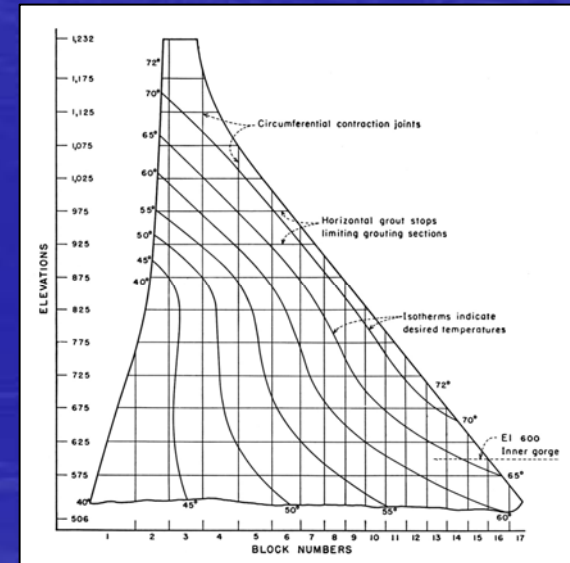

Monolithic blocks created to combat shrinkage; grouted in 100 foot increments

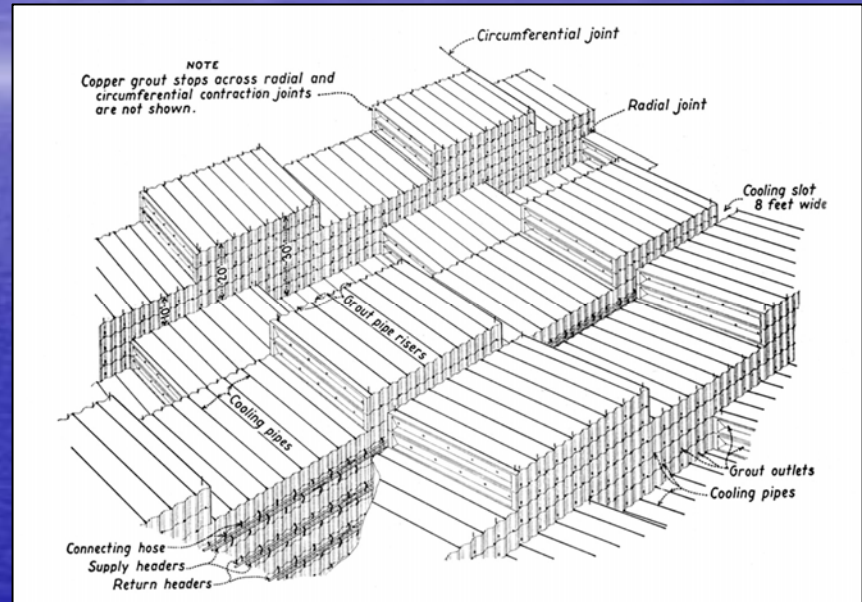
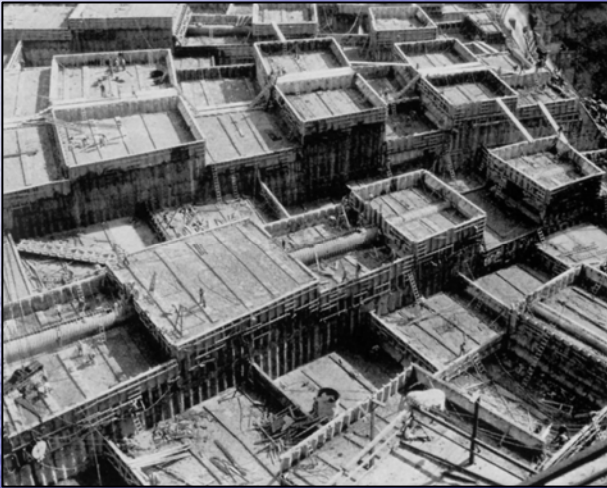

After the concrete heat of hydration was removed and the concrete shrank, the gaps between pour blocks and the cooling pipes were grouted under pressure to seal off any possibility of leakage. This became common practice on subsequent mass concrete dams world-wide.

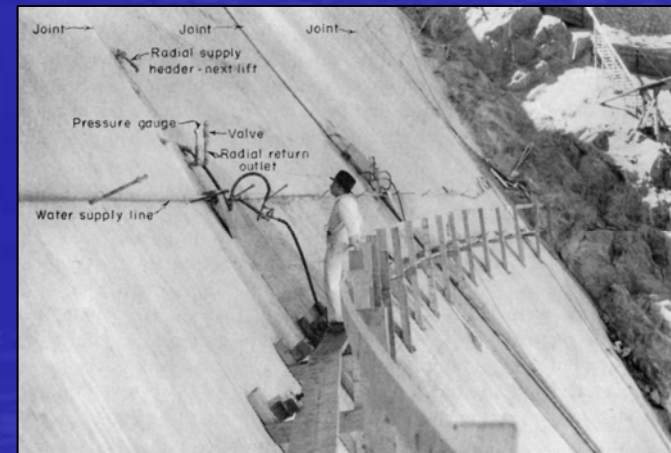

Myths about Entombed Bodies

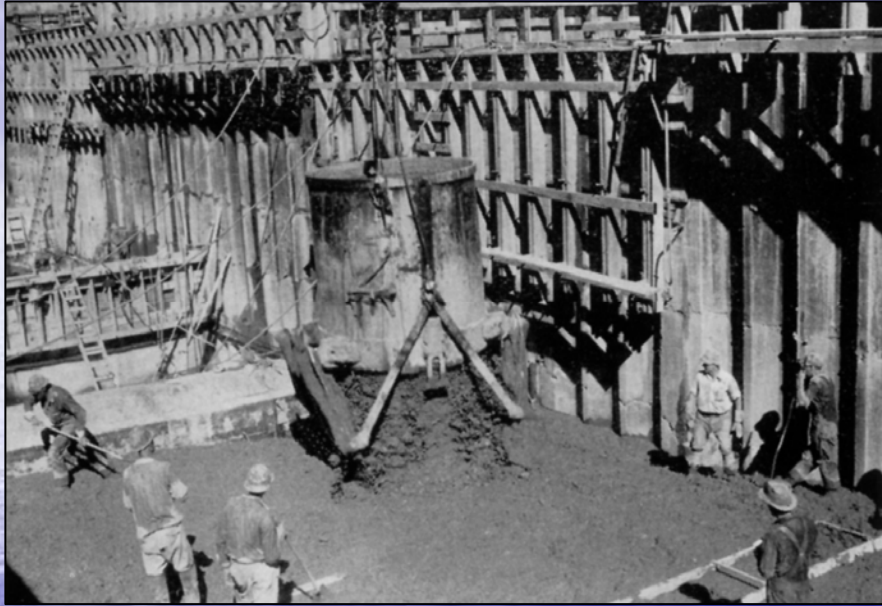

The official death toll during construction was 96 men. None were buried in the dam's low slump concrete.....

Each bucket of concrete contained 8 cubic yards; if you divide that volume over a 50 x 50 ft pour block, the depth of wet concrete would be just over 1 inch!

As a practical joke, a night shift tunnel crew fashioned a fake body with shoes and hard hat which was revealed when the concrete forms were removed!

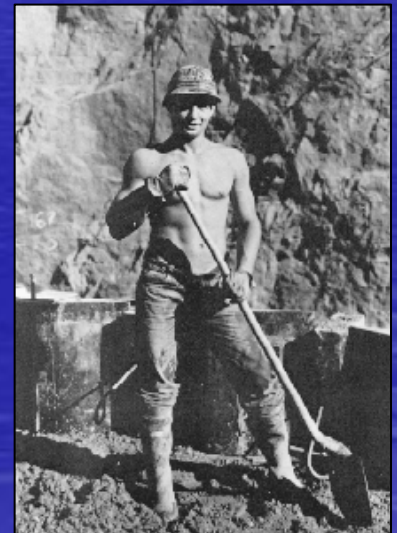



Dedication September 30, 1935

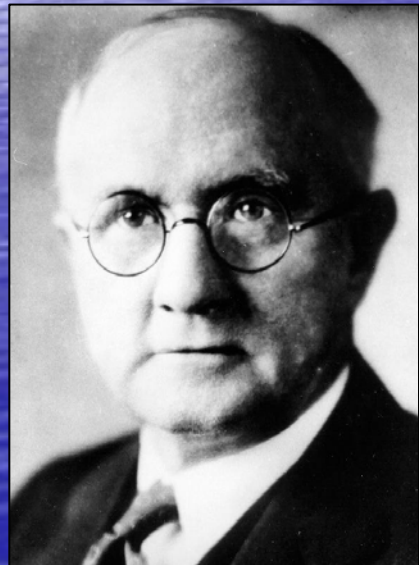
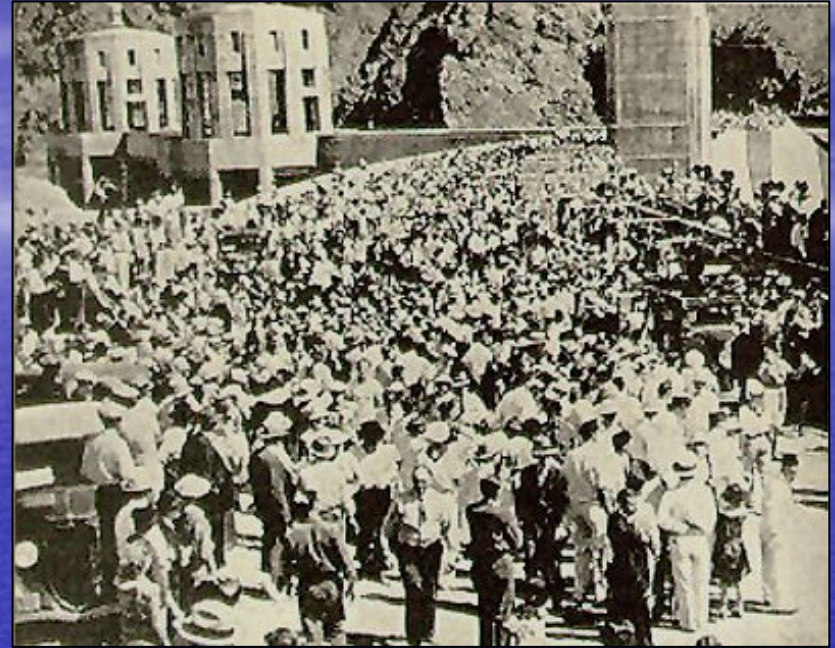

Reclamation Commissioner Elwood Mead referred to the project as "Hoover Dam"; while President Franklin Roosevelt christened it as "Boulder Dam"

Mead dies a few months later, and Walker R. Young was passed over as his replacement because he was a Republican

Name Controversy

Boulder Dam 1922-30: The Boulder Canyon Project was introduced in Congress in 1922; but not passed until December 1928.

Hoover Dam 1930-33: On September 17, 1930 Interior Secretary Ray Wilbur (upper left) officially began the project in Las Vegas and announced that the dam to be built in Black Canyon would be named Hoover Dam, in honor of the President's long association with the project.

Boulder Dam 1933-47: On May 8, 1933, Roosevelt's new Interior Secretary Harold Ickes decides the name should revert to its original moniker, Boulder Dam.

Hoover Dam: On April 30, 1947 the 80th Congress passed a resolution changing the name back to Hoover Dam, which is signed into law by President Truman

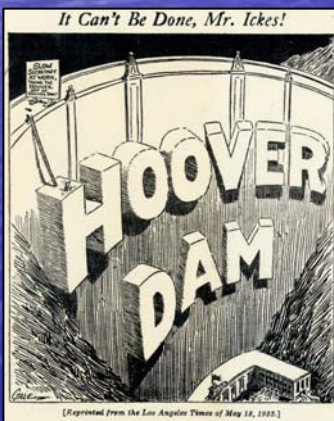
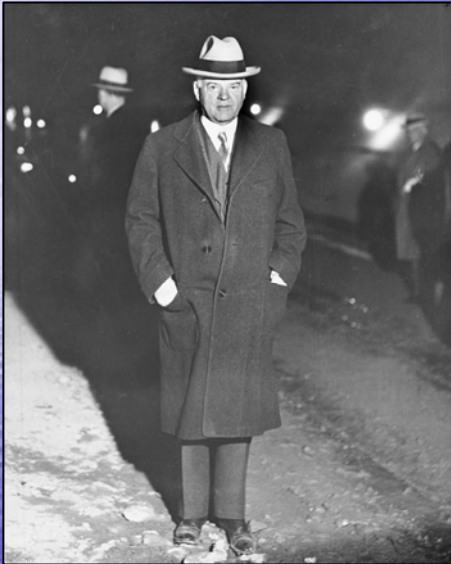

The Wild River Is Tamed

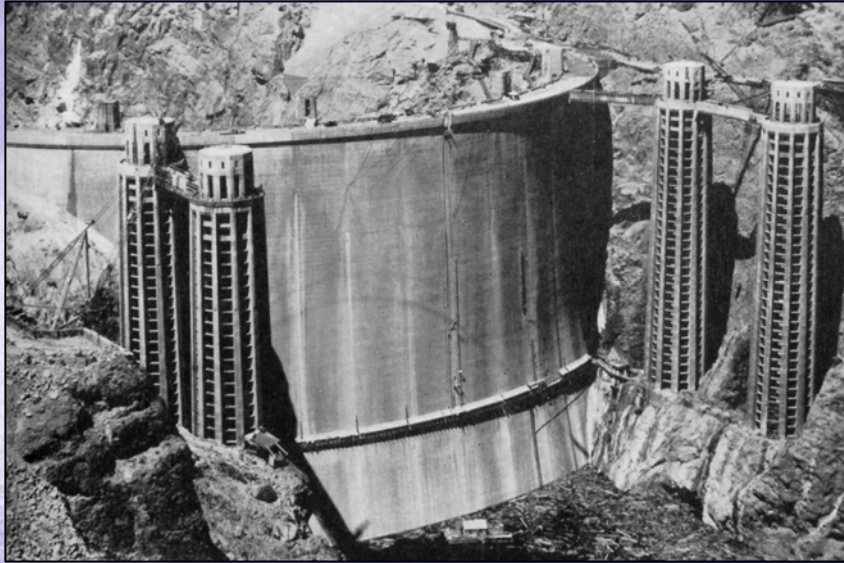

Storage of water behind the dam began on February 1, 1935

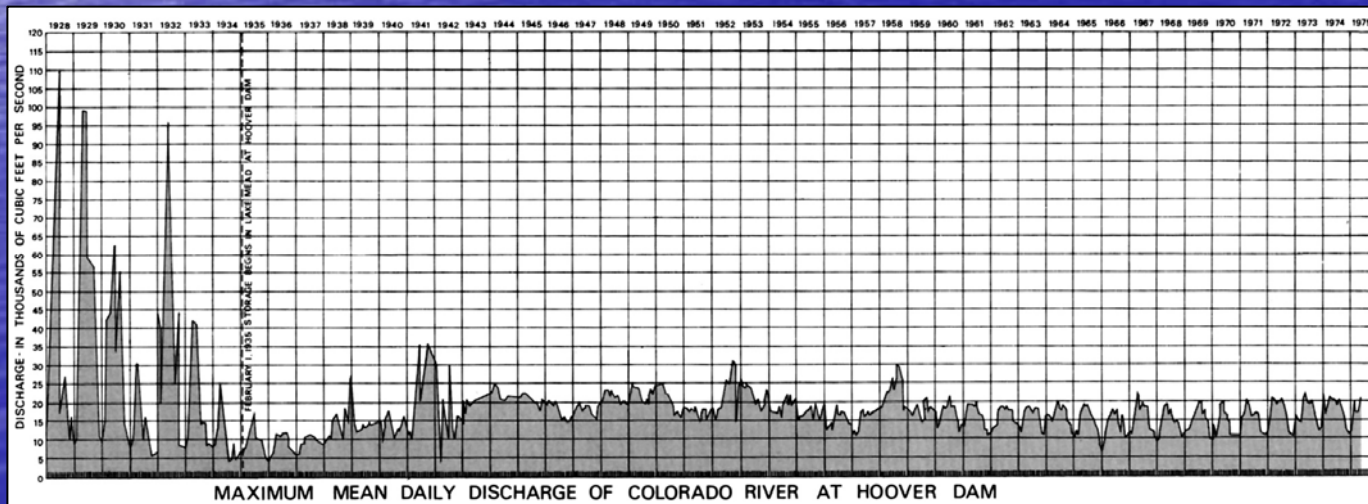

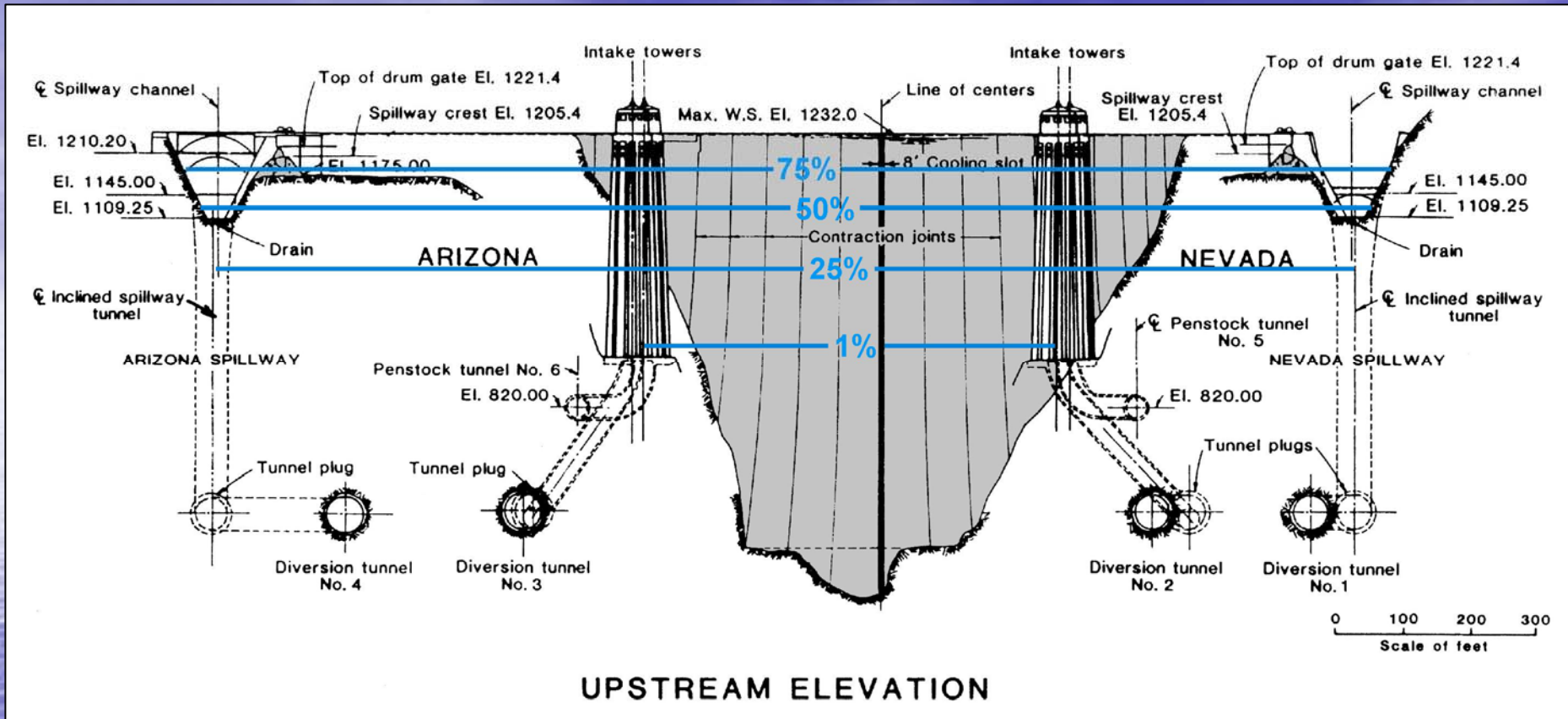

- The storage capacity of Lake Mead increases dramatically in the uppermost elevations of the dam. Note how the lower half of the dam only retains 1% of the water!

World's Largest Spillways

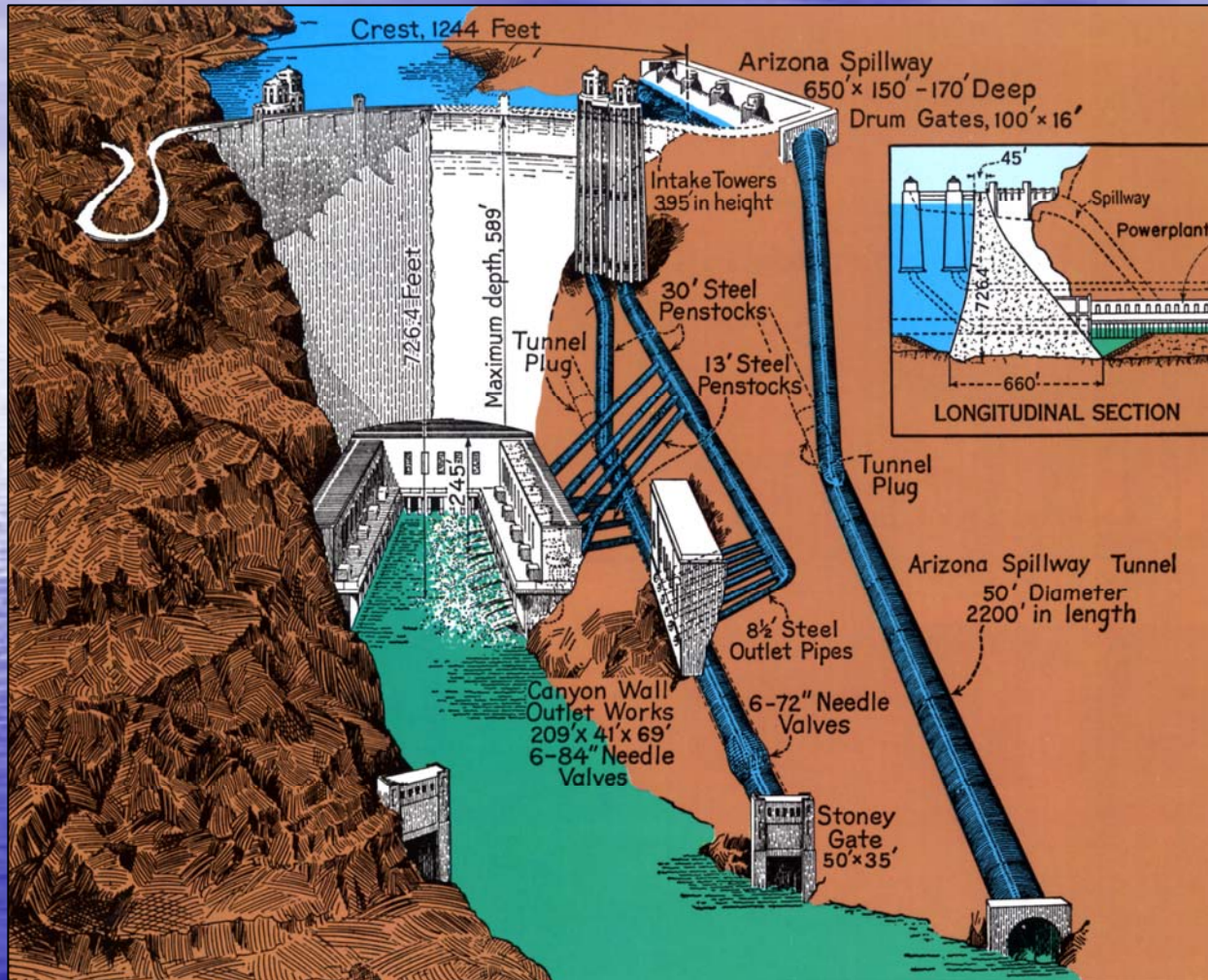

The outer bypass tunnels were connected to enormous side channel spillways; giving the dam an aggregate spillage capacity of 520,000 cfs

Spillage Capacity

- The two side channel spillways were designed to accommodate **400,000 cfs**
- The canyon wall outlet works could discharge an additional **48,000 cfs**;
- The tunnel plug outlet works could discharge up to **43,200 cfs**;
- The powerhouse turbines were assumed to pass **28,800 cfs**; but could pass **50,000 cfs** today.



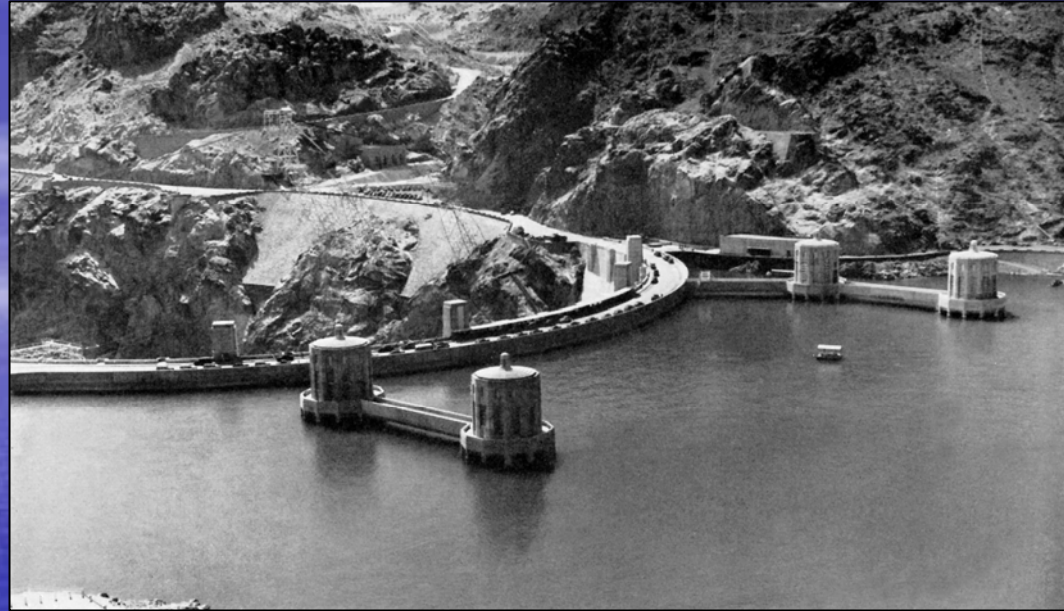

Spillway test August-October 1941

Lake Mead topped out in August 1941

BurRec designers wanted confirmation on the design assumptions they had employed and the dam was fully instrumented. So, as downstream water demands allowed, Lake Mead was brought to maximum pool level and the spillways were tested between August and October 1941

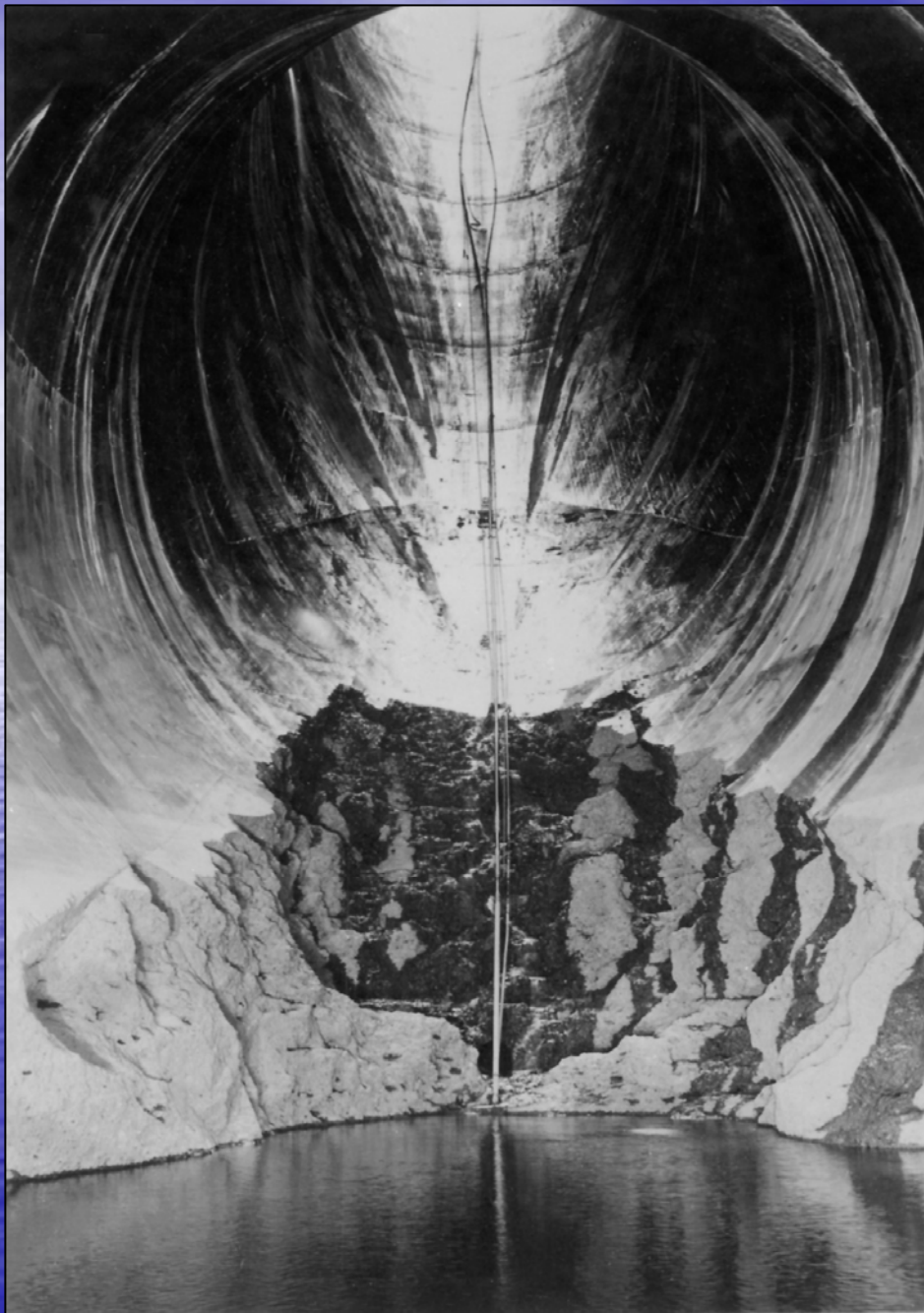

Cavitation Damage in 1941

- BurRec engineers were surprised to discover that the spillways experienced severe cavitation
- They wrongly ascribed this to a $\frac{1}{2}$ inch variance in alignment of the tunnel lining

Spillway Cavitation in 1983

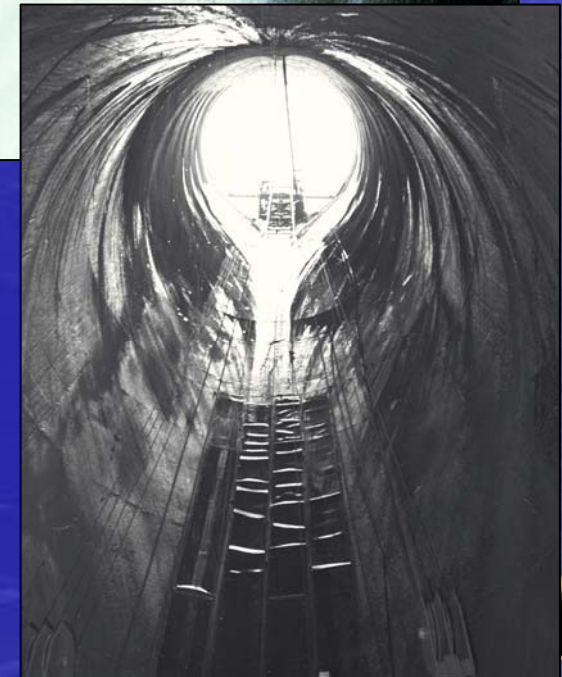

The spillways were next used in 1983 because of excessive runoff and a flawed computer program that was supposed to model runoff in the upper Colorado Basin. As in 1941, excessive cavitation damage occurred at the heel transition with the old bypass tunnel. BurRec undertook an emergency retrofit of aeration slots in the spillway tunnels at Hoover and Glen Canyon Dams later that year.

Security Precautions during WW2



German agents tried to sabotage the intake towers using satchel charges from a rented boat in Dec 1939; then tried to bomb the switch yard at Boulder City in February 1943. Both of these attempts were foiled by the FBI, but security measures included Army guards, closing the dam to tours, installing checkpoints, and convoying traffic across the dam.





- Plaster model of camouflage scheme during World War II using camouflage nets suspended from cables.



- The Basic Magnesium Plant and the community of Henderson were built during the war to supply this strategic metal for the aircraft industry

First Reservoir Induced Seismicity and Crustal Deflection Studies

Three precise leveling surveys performed 1935, 1940-41, and 1949-50. A seismic array was also monitored.

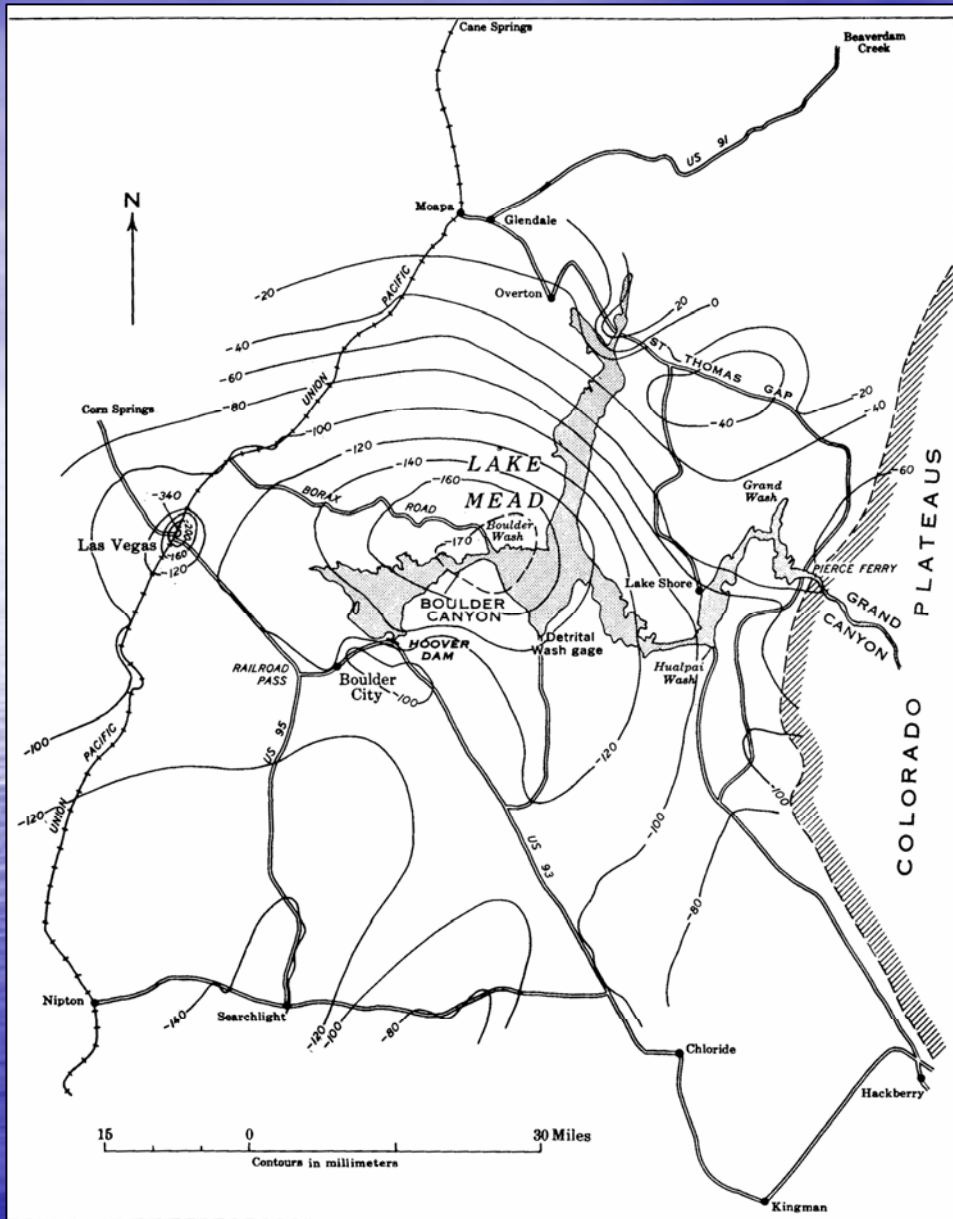

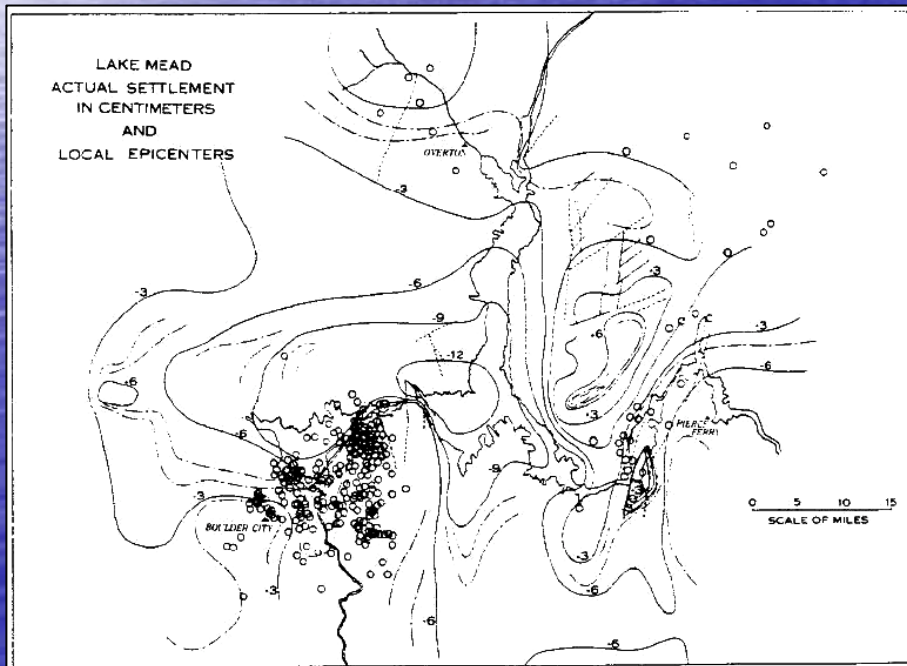
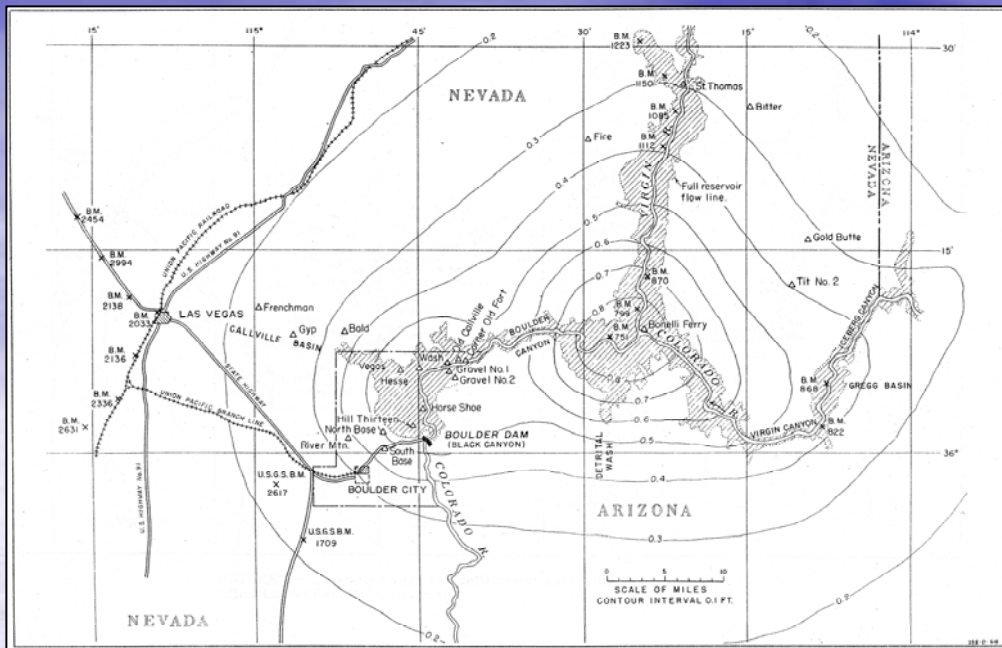
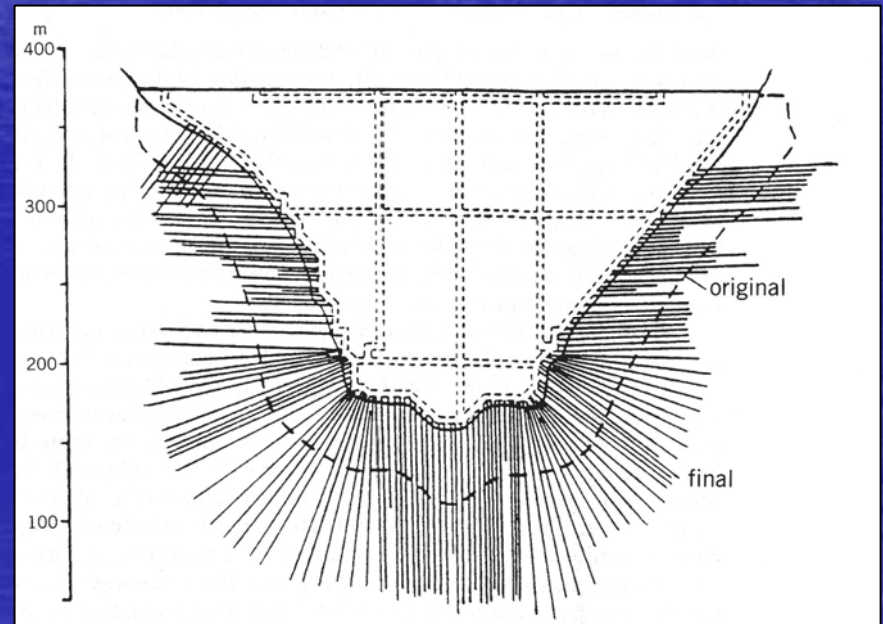
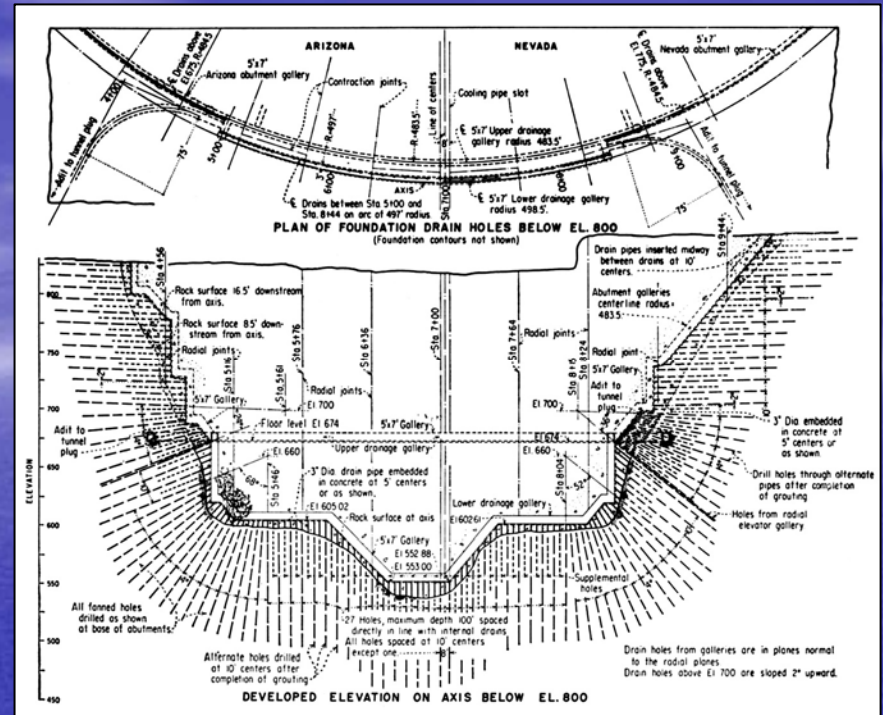
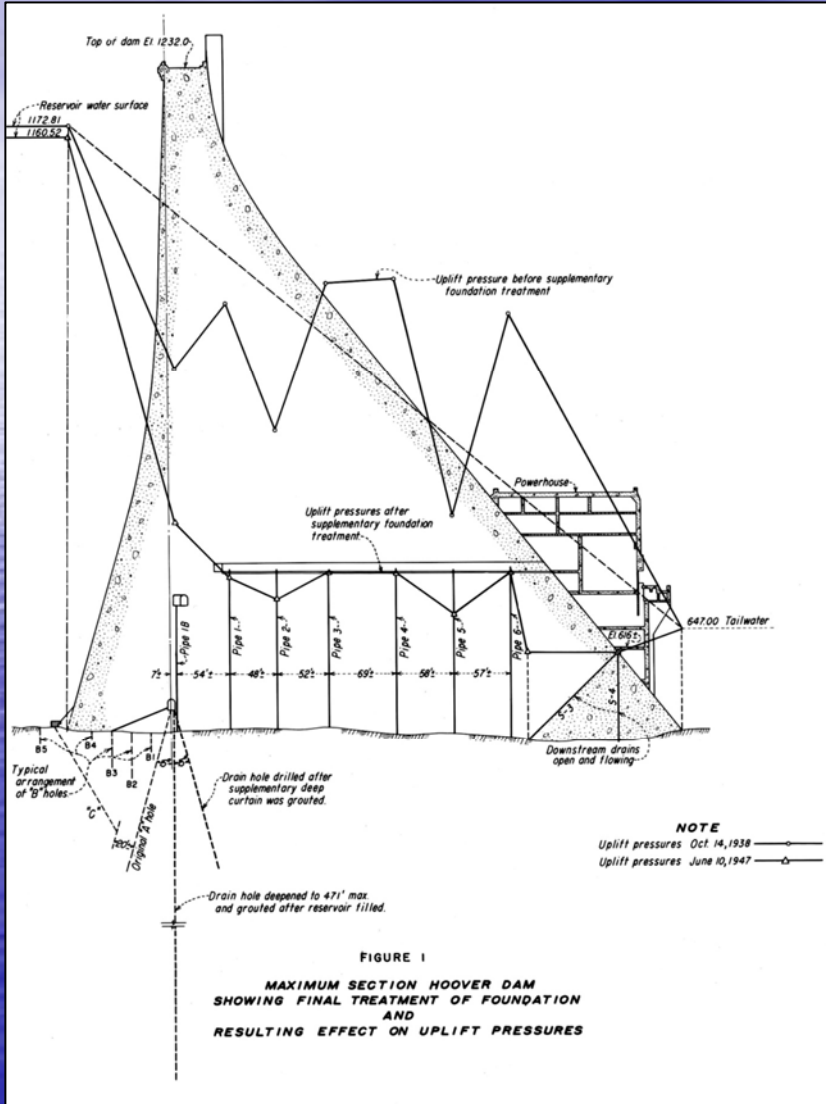

Fig.13 Subsidence from 1935 to 1941, and lokal epicenters (small circles) from 1941 to 1946 (from Carder and Small,1948)

- **Crustal settlement** was very close to that predicted for an assumed mass of **granite crust** behaving elastically, under 41,500 million tons of water
- **Predicted deflections** up to 10 inches; actual deflections were up to 7.5 inches.

Failure of the Grout Curtain



Sedimentation Studies

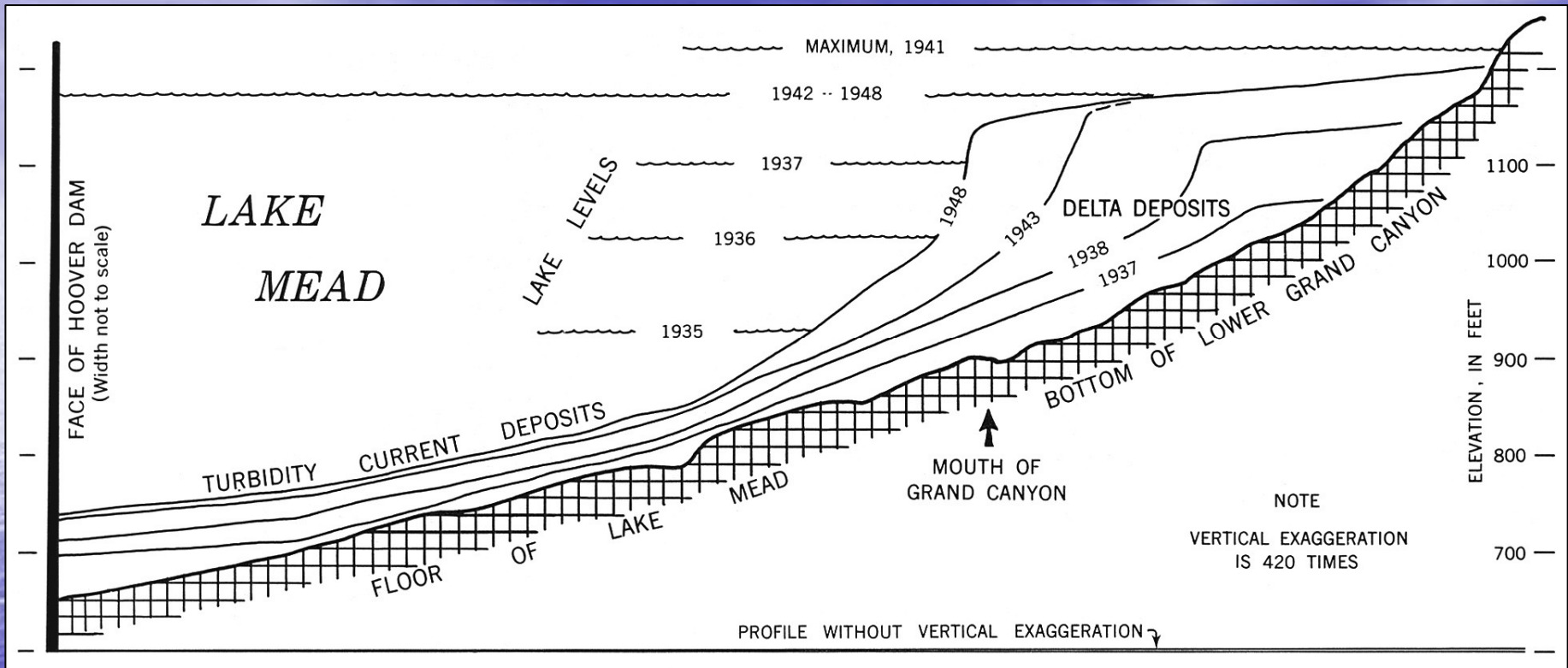

Bathythermography tests adjacent to the dam's upstream face revealed unusually high temperatures from biologic reduction of nutrient rich silts brought 115 miles across the sinuous course of the old river channel by turbidity currents.



Reservoir Area and Capacity Curves

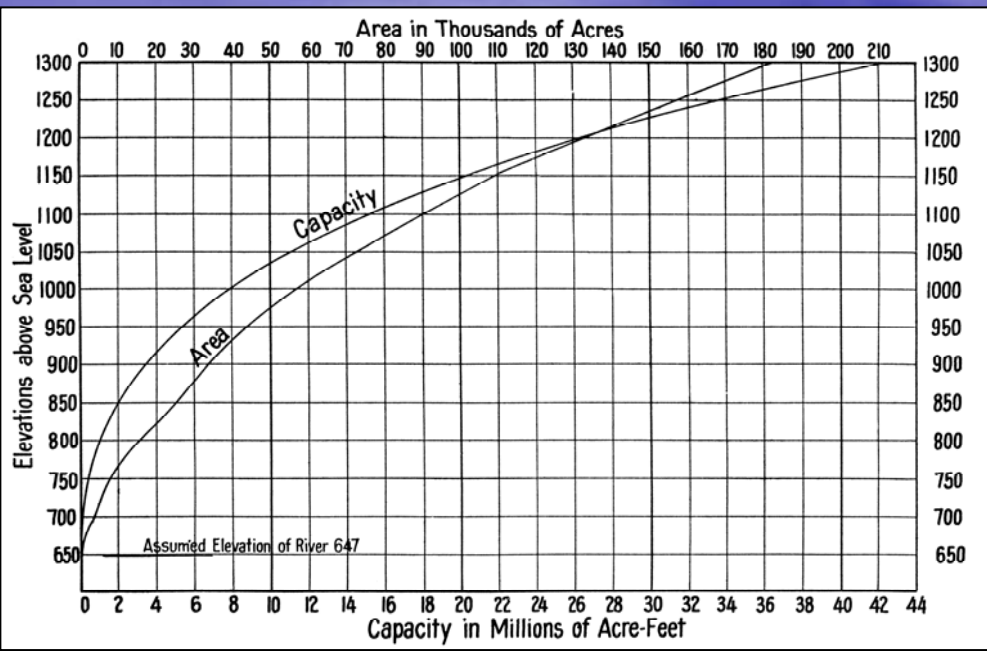

- Between 1935 and 1964 Lake Mead lost 3 million acre-feet of reservoir capacity due to siltation
- That figure dropped dramatically after the completion of Glen Canyon Dam in 1964

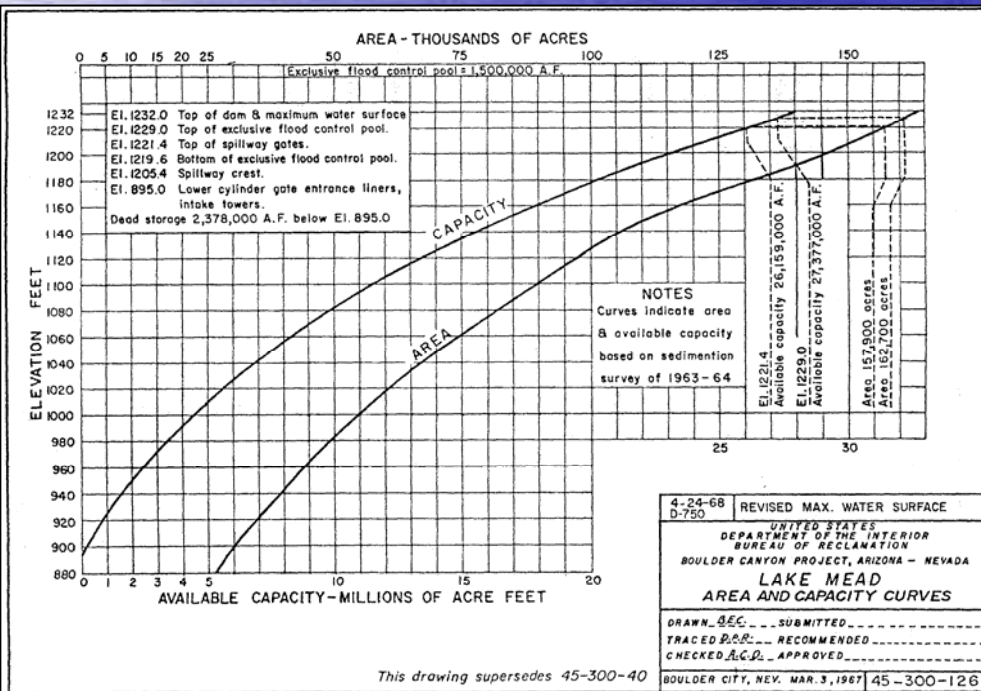

Siltation studies



Hoover Dam had a design life of just 150 years before Lake Mead was expected to silt up, without any upstream dams. But about 50% more silt entered Lake Mead than passed Lee's Ferry (360 miles upstream) actually made its way to upper Lake Mead; the lion's share of the silt emanated from the San Juan and Little Colorado River Basins.

Lake Mead sediment studies

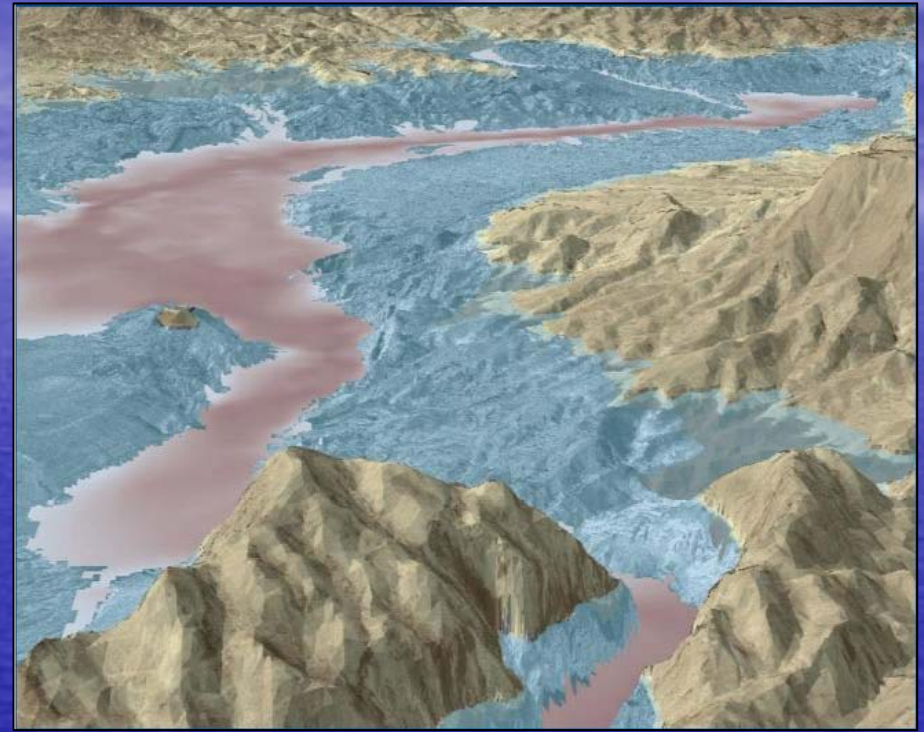
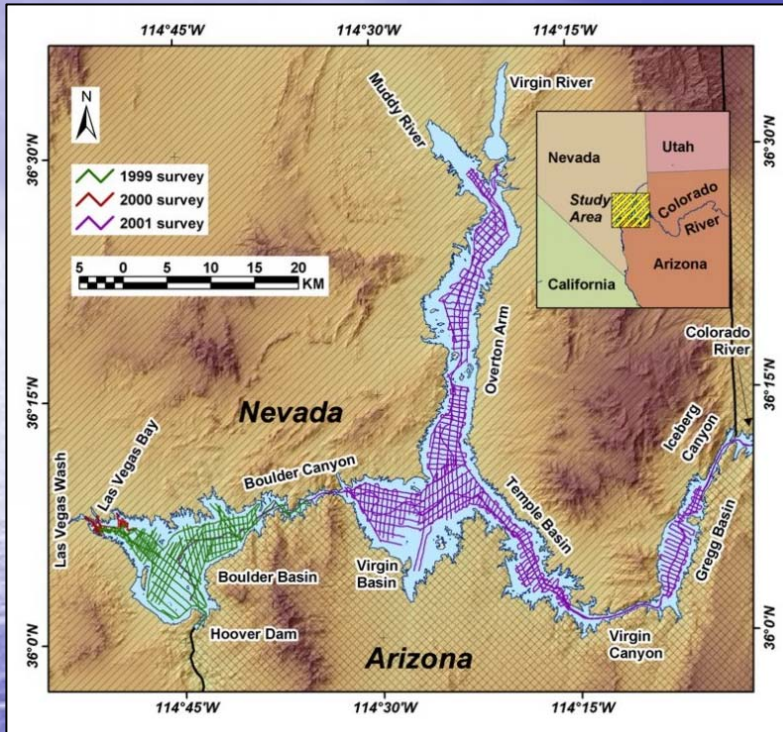

The tailwater channel and deep basins of Lake Mead are being infilled with silt coming out of the Grand Canyon. The annual influx was reduced substantially when Glen Canyon Dam closed its gates in the fall of 1964.

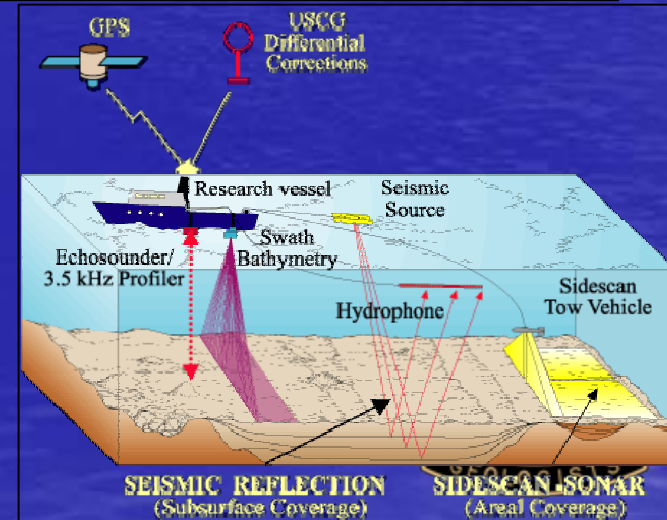

Hoover Dam's success has been emulated the world over.....

- Bahkra Dam in India
- Chinman Dam in Taiwan
- Aswan High Dam in Egypt
- Karun Dam in Iran
- Chivor Dam in Columbia
- Guri Dam in Brazil
- El Cajon Dam in Honduras
- Three Gorges Dam in China

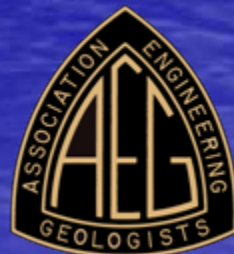

Popularity as a Tourist Attraction Continues to Rise



- Tourism feeds off Las Vegas as a major vacation destination
- 750,000 visitors per year at the dam
- 6 million people per year recreate on Lake Mead
- Boulder City survived transition; but still does not allow gambling

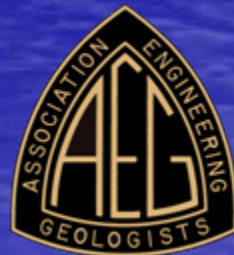

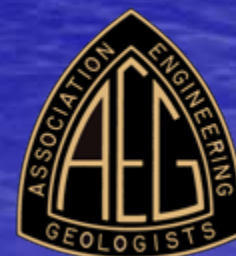

Special thanks to:
Jonathan Rogers
Ece Karadeniz
Deniz Karadeniz
Jae-won Chung
Conor Watkins
Karen Cowan

This lecture will be posted at:

www.umar.edu/~rogersda

In .PDF format for easy downloading