



DRAINAGE REQUIREMENTS AND MAINTENANCE OF HOMESITES

9-1 INTRODUCTION

Four grading considerations are basic for the safe development of any construction site, whether on flat land or on hillsides: (1) drainage, (2) erosion control, (3) soil stability, and (4) settlement.

Providing proper site drainage is fundamental to achieving the other conditions, because improper drainage often contributes to erosion, instability, and differential settlement. The potential for erosion caused by improper drainage is obvious. Proper drainage is also a vital consideration with expansive soils because they expand in proportion to their moisture content. While cracked slabs from differential settlement in flatland areas are generally caused by inadequately compacted fills or by settlement of peat or organic sediments, inadequate drainage is often a contributing factor to this failure also.

Even though hillside areas require more critical evaluation and review by professional consultants because of their dramatic potential for failure, we do wish to impress upon

the readers once again the importance of having professional supervision of flatland development to avoid or minimize potential problems. For this reason, the Uniform Building Code requires design and supervision of grading construction by professional consultants in all grading, whether on hillside or flatland areas. This supervision includes investigations, coordination with design, supervision during construction, certification of safety and stability at the rough-grade stage prior to issuance of building permits, and final certification prior to occupancy. The building official reviews the data, assures that they are incorporated into the design of the grading plan, and inspects to ensure that the work is being conducted according to the permit, approved plan, and grading code.

It is important to recognize the division of responsibilities between the professional consultant—who investigates and evaluates site conditions, and who designs, supervises, controls, and certifies construction—and the building official, who reviews the plans and who periodically checks and inspects construction.

Drainage control and maintenance of drainage devices and slopes is the responsibility of the hillside homeowner, who, in most cases, seems unaware of what constitutes proper maintenance. Therefore, it is not surprising that the majority of damaging slope failures that occurred to residential sites during heavy rains of 1962, 1969, 1978, and 1980 in Southern California were caused by abuse of engineered slopes. The most common abuse to engineered slopes is the overwatering of the slopes with mechanical, often automated, sprinkling devices. The already saturated slopes suffered near-surface failures during rainstorms, causing mud flows that inundated downslope yards and homes.

This problem of abuse of engineered slopes must be resolved. The most apparent way to solve the problem is to educate homeowners about proper maintenance of their hillside homesites.

While government officials cannot clean up or correct rain damage or landslide conditions on private property for the sole benefit of the private property owners, government officials can provide educational programs to assist homeowners in understanding the importance of responsible maintenance of hillside homesites and the proper methods to use.

9-2 DESIGN STANDARDS FOR DRAINAGE

Drainage—both existing and proposed—is the basic consideration in the design of grading. Providing for adequate drainage onto and off of the proposed site is one of the most important aspects of grading plan design since the best compacted fill or graded slope can be completely nullified by inadequate drainage provisions. Building departments use minimum drainage requirements established within either Chapter 70 of the Uniform Building Code (UBC) or within the minimum standards of their own governmental agencies. These requirements are based upon experience with and knowledge of past performance of various types of drainage plans used in a wide variety of environmental conditions. These are *minimum* standards, not maximum design provisions, that guarantee adequacy under all conditions, and the site designers should utilize them as such. (See Figures 9-1 through 9-7.)

The design engineer, in coordination with the soil engineer and the engineering geologist, must determine the necessities of each individual site on its own merits, and design for problems peculiar to the site. Long-term performance must be considered with enough conservatism in design provided to take into account the general lack of maintenance received by hillside residential sites.

Drainage provisions are designed to eliminate potential instability and minimize erosion by removing the drainage rapidly before it has a chance to be impounded or be diverted, even during intense rainy periods. While careful engineering cannot eliminate the necessity of maintenance,

it can reduce the amount of maintenance needed so that with minor but consistent effort, the hillside homeowner can effectively assure the stability of his homesite. Site maintenance is discussed later in this chapter.

Resulting from the best efforts of three experienced, professional specialists, the approved grading plan, along with provisions of the grading permit, should provide basic, overall directions for safe construction to assure public safety and welfare. The plan—in addition to showing existing conditions, how the site is to be reconstructed, and the final site conditions proposed—should also provide the methods of performance, construction, and supervision by all those persons who should be involved in providing the final product. To achieve maximum safety and economy of construction, supervision, and inspection, government and industry efforts must be carefully coordinated.

Drainage Gradients

The requirement to grade the building pad at a minimum of 2% slope in hillside areas is necessary to assure that water from graded but unimproved lots is directed to disposal areas in an efficient, positive manner in order to avoid ponding and other undesirable situations. This is especially important in hilly terrain where slopes as well as pads must be protected. If a pad is left idle over a long period, it will deteriorate and may require regrading prior to construction.

Where buildings are to be erected immediately, and in anticipation of the individual lot owners being available to maintain drainage, 1% swales have been adequate; but the lots are still graded at 2% to the swales. (See Figures 9-5 through 9-8.) In flatland, this requirement has been reduced to 1% when borrow fill dirt is unavailable and water will not be impounded on adjacent property.

The following *minimum* gradients for drainage have normally been required for development of private property:

1. Dirt, grass, etc.: 1.0%
2. Asphaltic concrete: 1.0%
3. Portland cement concrete: 0.5%
4. Private streets and driveways, in flowline paved with Portland cement concrete: 0.2%
5. Hillside single-family residential subdivision—rear yard: 2.0%
6. Hillside lots for sale—overall: 2.0%
7. Maximum gradient for sheet flow: 10.0%
8. Maximum gradient for concentrated graded swale (dirt): 4.0%

Drainage standards for slopes are established to prevent excessive erosion and subsequent instability. No surface water from buildings or pads should be permitted to flow over the slopes. Drainage from the natural slopes above the graded cut slope should be diverted away by a brow-ditch drain or a diverter drain. (See structure “C,” Figure 9-1. See also Figure 9-3 for location of the brow-ditch drain at the top of the excavated slope.)

STRUCTURE "A"

INTERCEPTING TERRACE FOR SLOPES

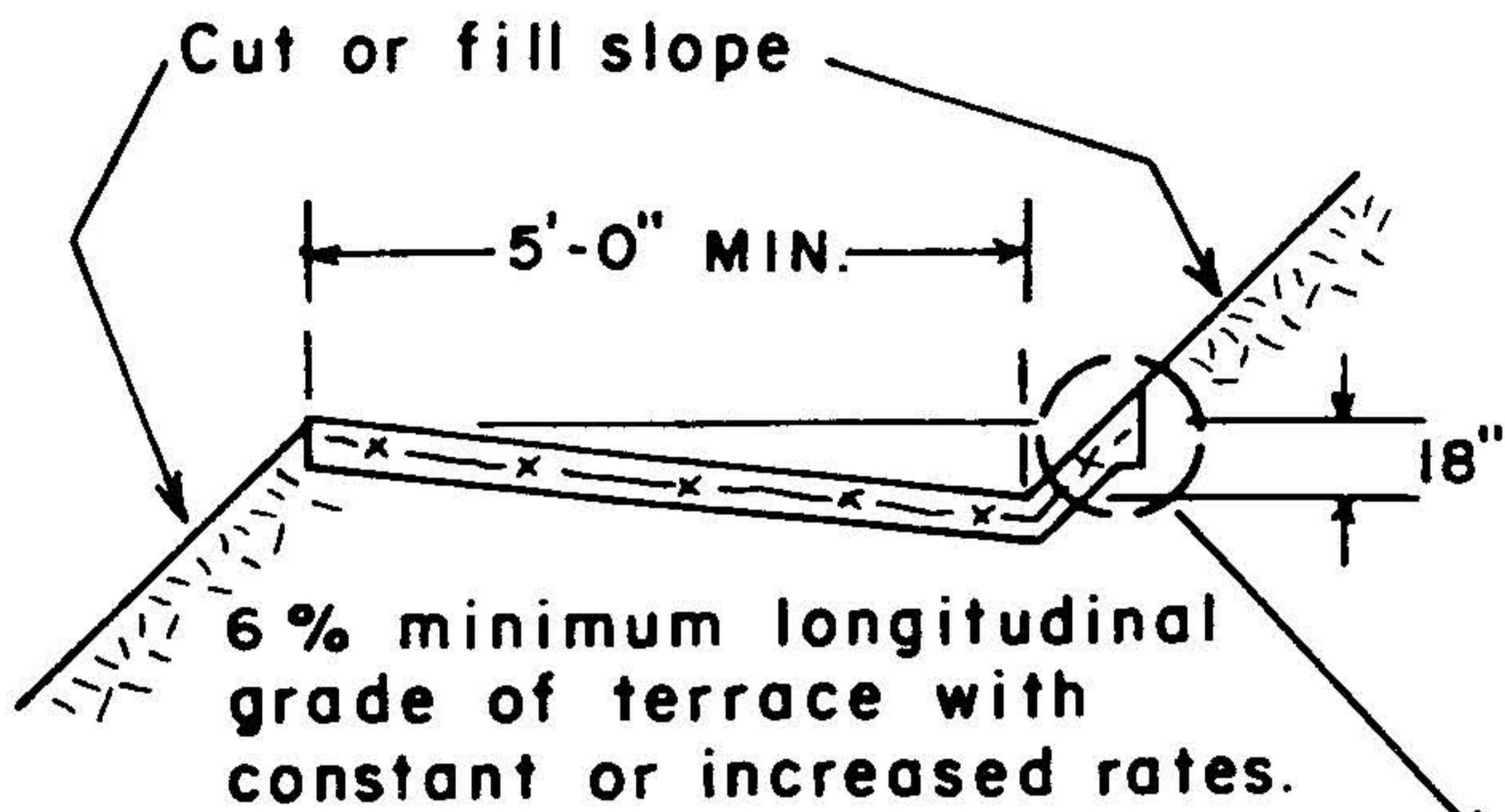

STRUCTURE "B"

DIVERTER TERRACE TOP OF CUT SLOPES

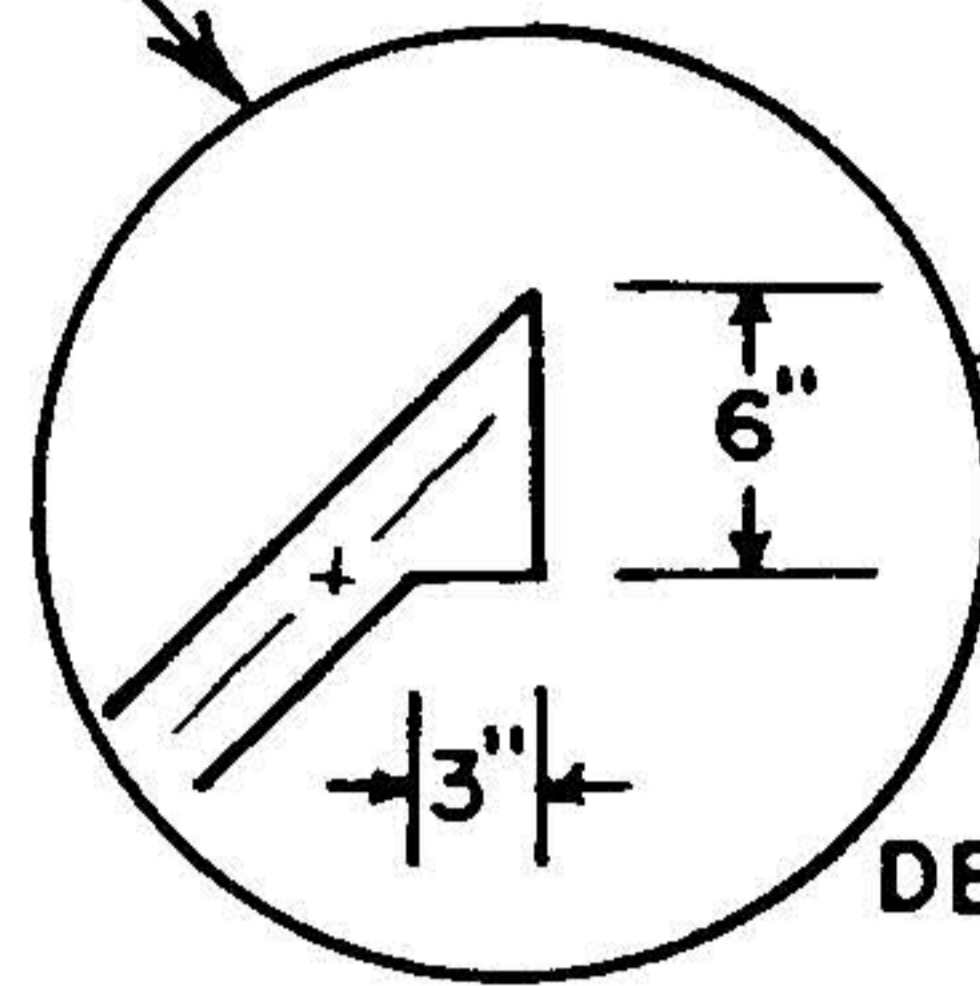
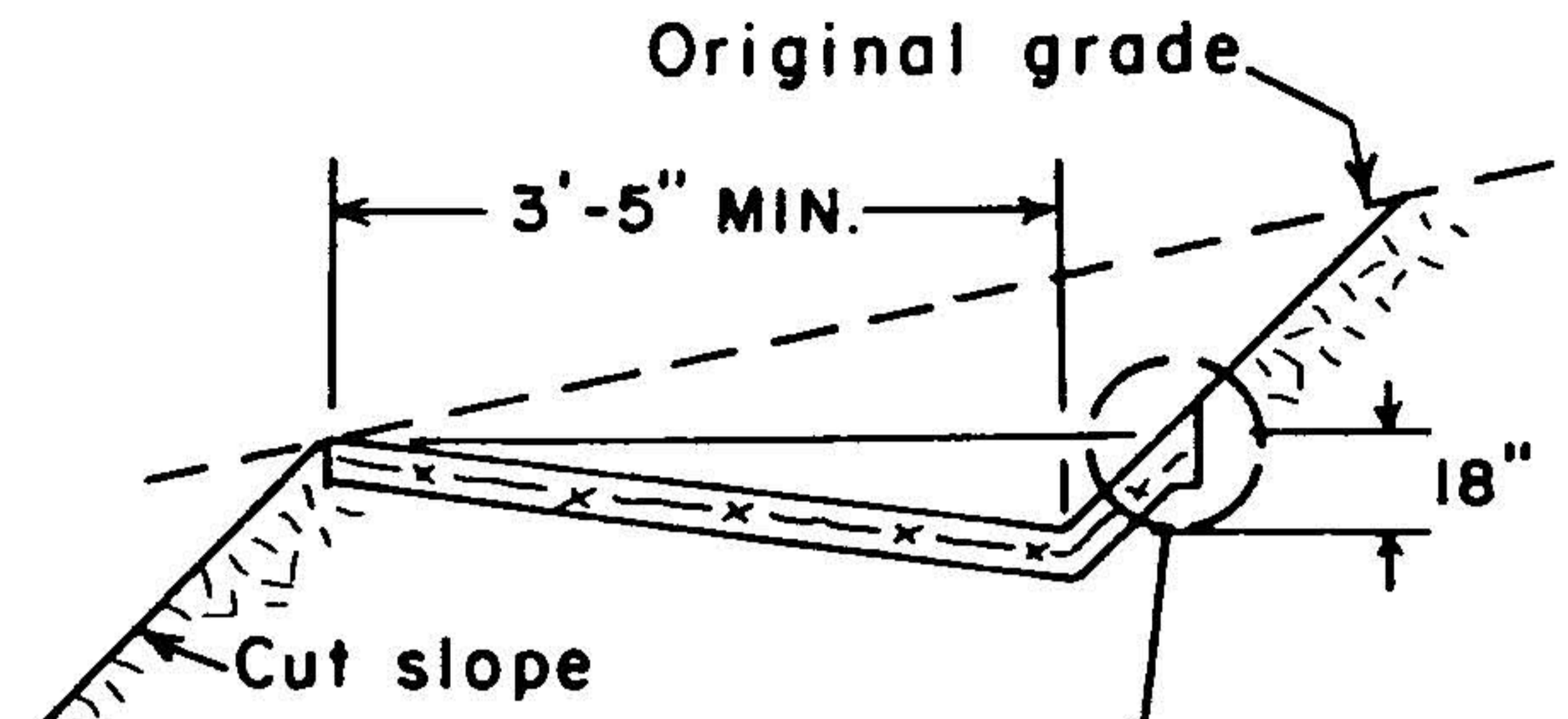

DETAIL (SEE ABOVE)

STRUCTURE "C"

TO CONDUCT TERRACE DRAINAGE TO THE STREET OR IMPROVED DRAINAGE DEVICE

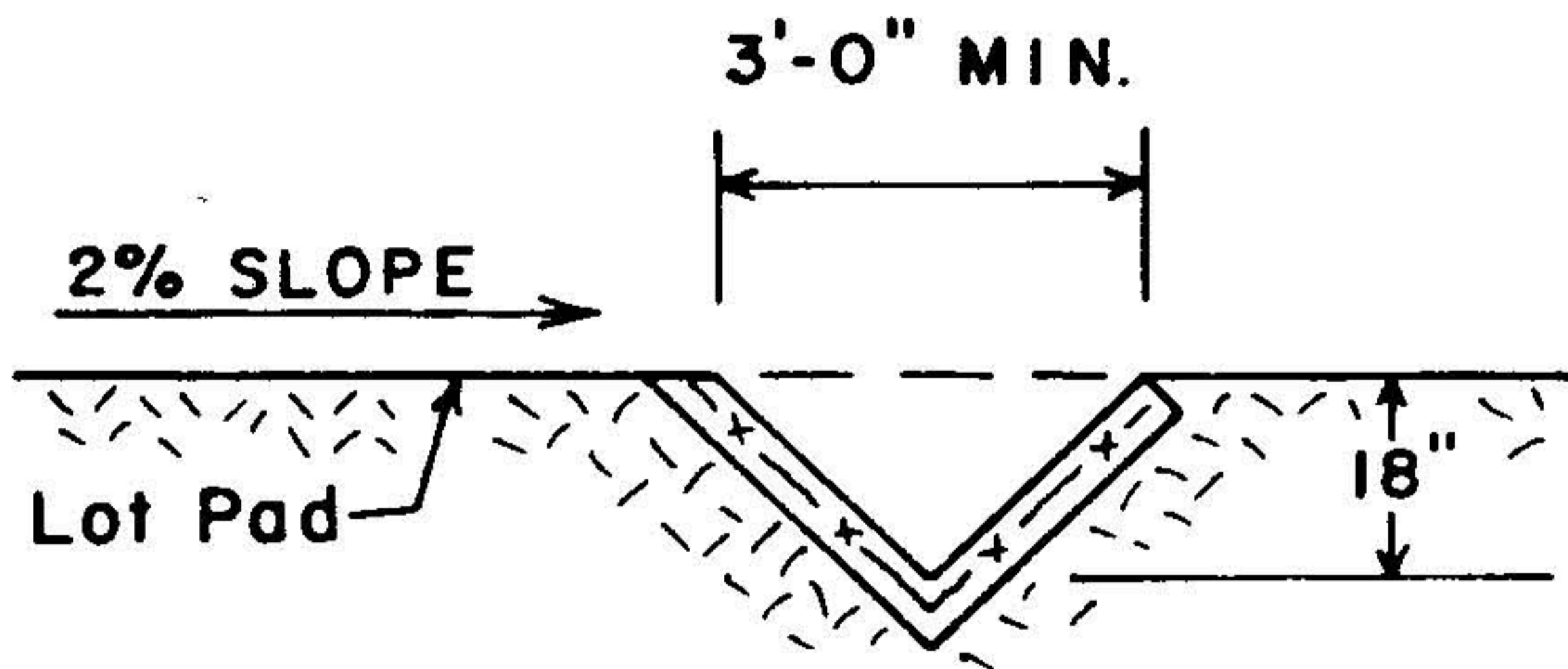

Capacity should be adequate to handle anticipated flow and must be checked by the designing Civil Engineer.

STRUCTURE "D"

DOWN DRAIN AND ANCHOR

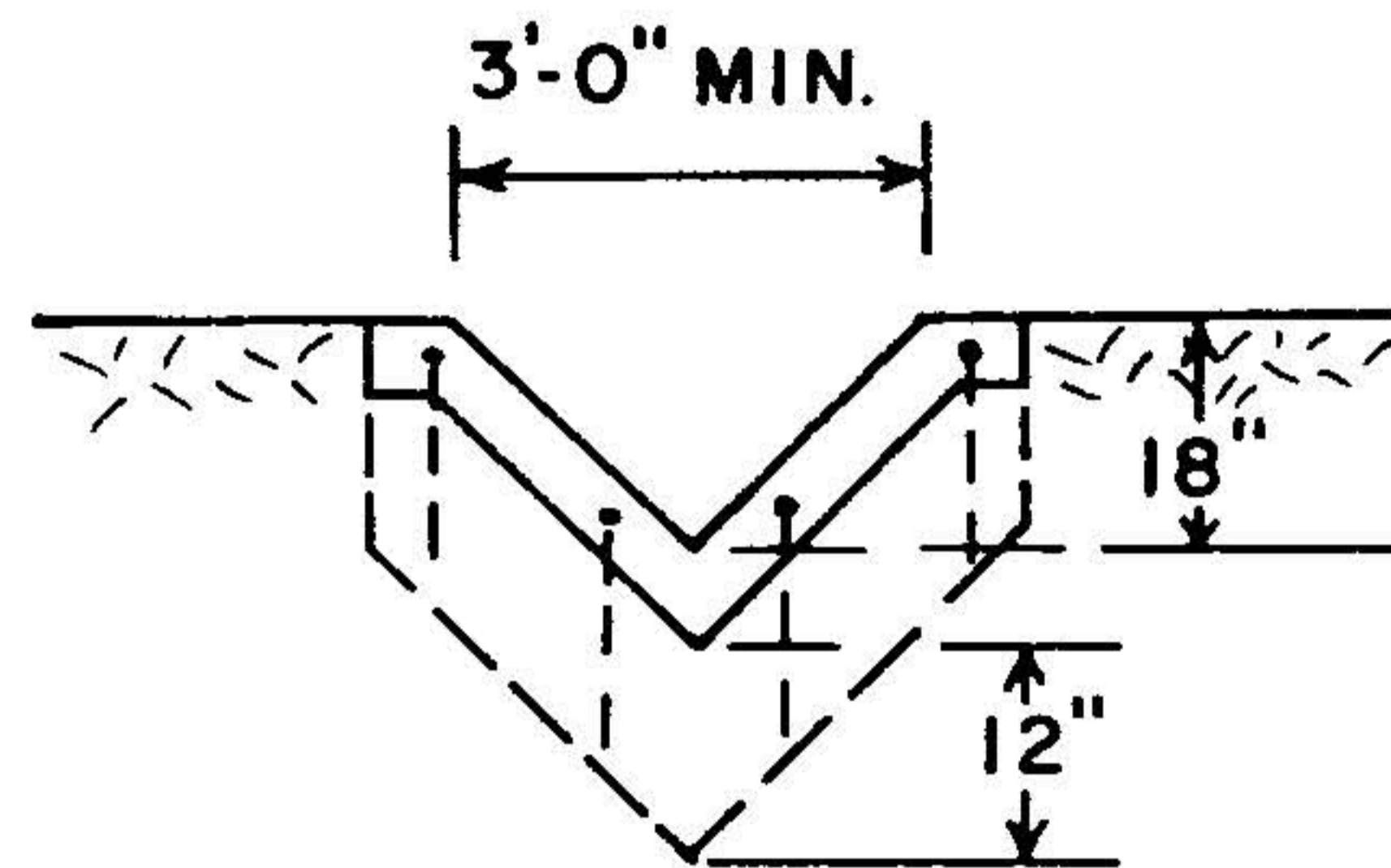

Down drain anchors to be constructed every 10' of vertical height.

Suggested minimum reinforcement, Structure "D"
 #3 bars as shown with
 #3 tie bars 4' O.C. anchor
 dowel to be tied to longitudinal bars
 or 6" X 6" #10 #10 W.W.M.

Suggested minimum reinforcement for Structures "A", "B", & "C"
 3" concrete with #3 bars longitudinal 24" O.C. with #3 tie bars 4' O.C.
 3" gunite with 2" X 2" #14 #14 W.W.M.

NOTE: Grading inspection during installation is required for all devices. Must pre-wet graded swale prior to paving. Paved drains must be cured with a moisture loss retarder.

Redrawn from County of Orange, CA.; Minimum design recommended by Michael Scullin.

Figure 9-1 Recommended minimum slope drainage devices.

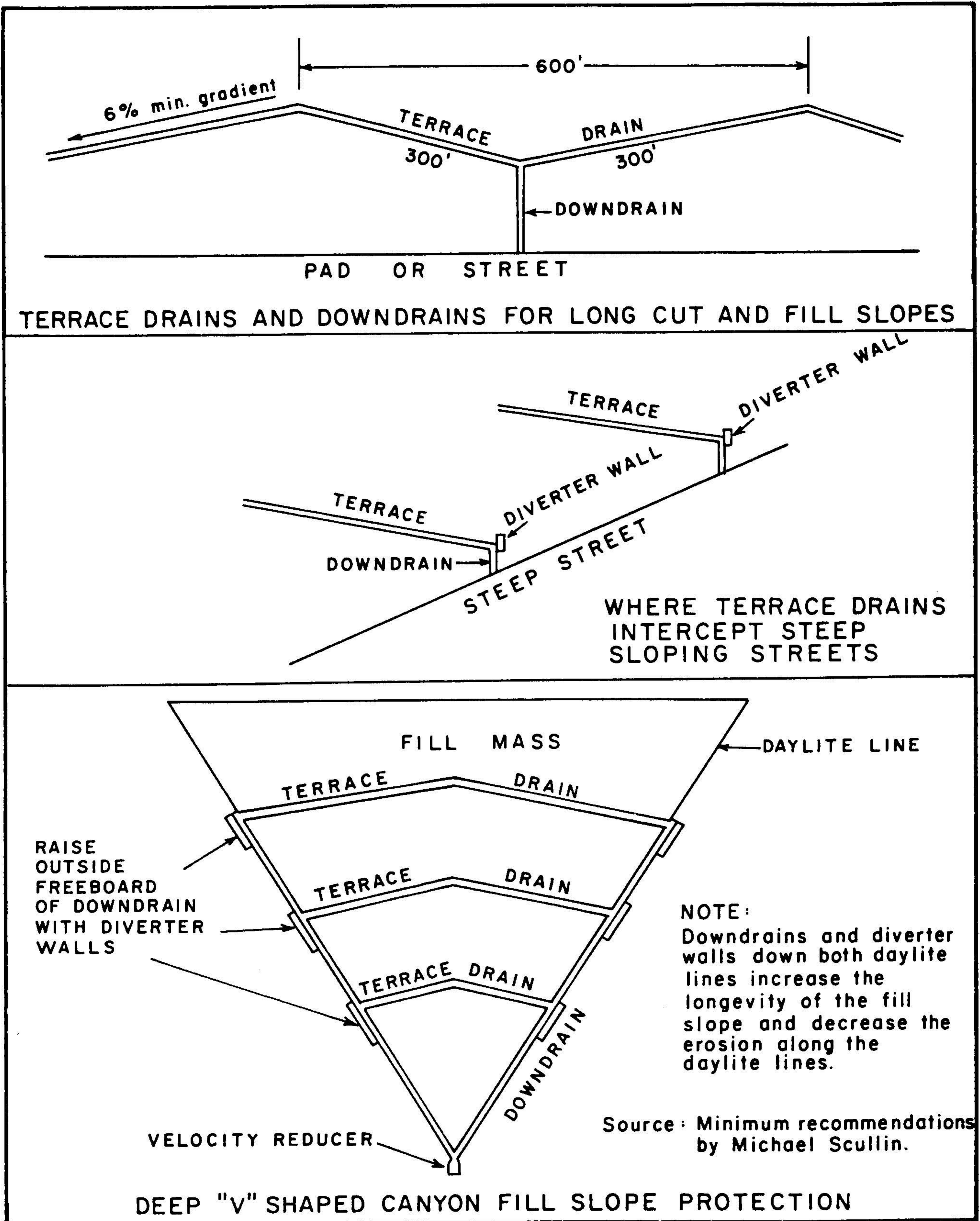

Figure 9-2 Distances between down drains.

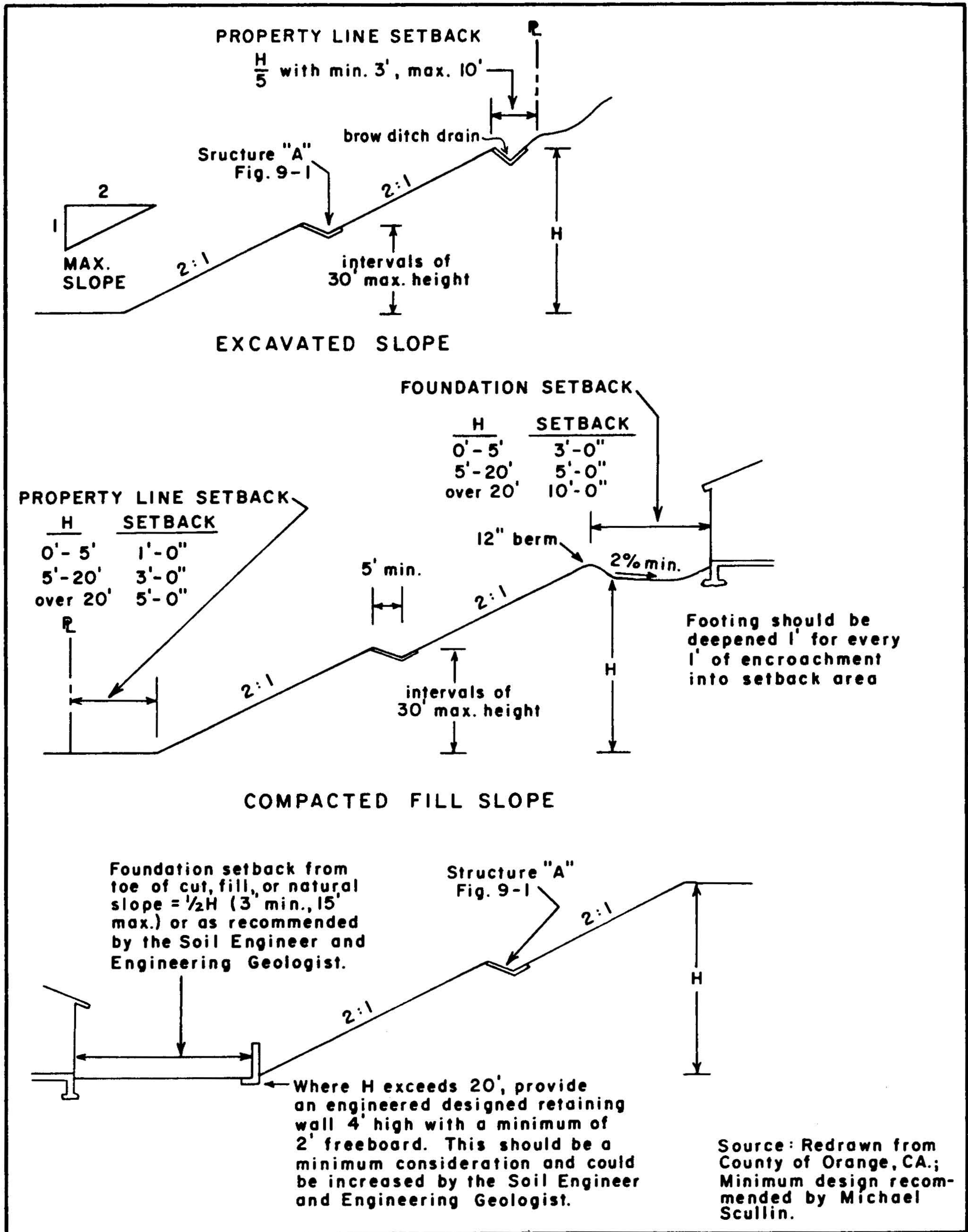
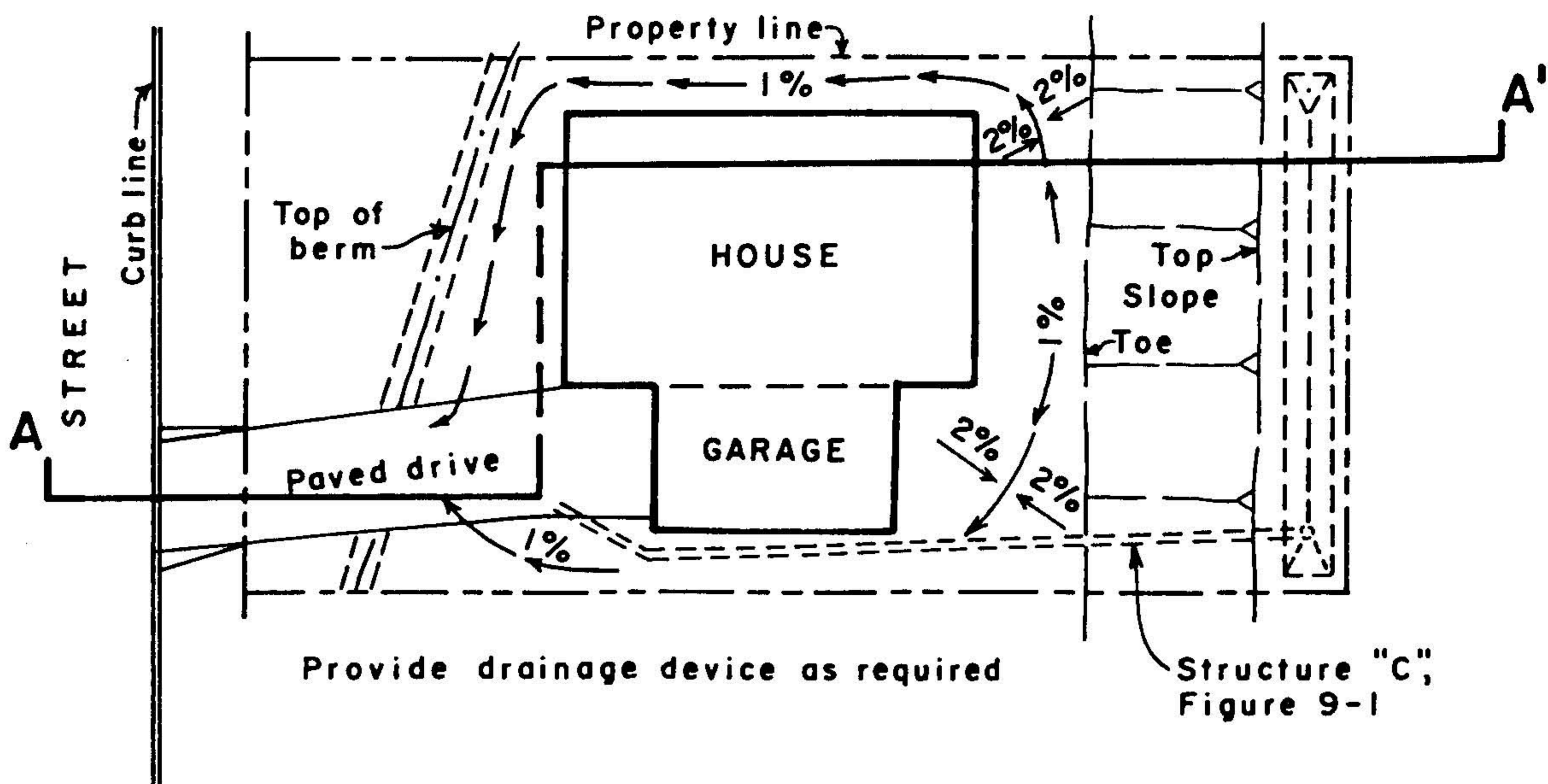
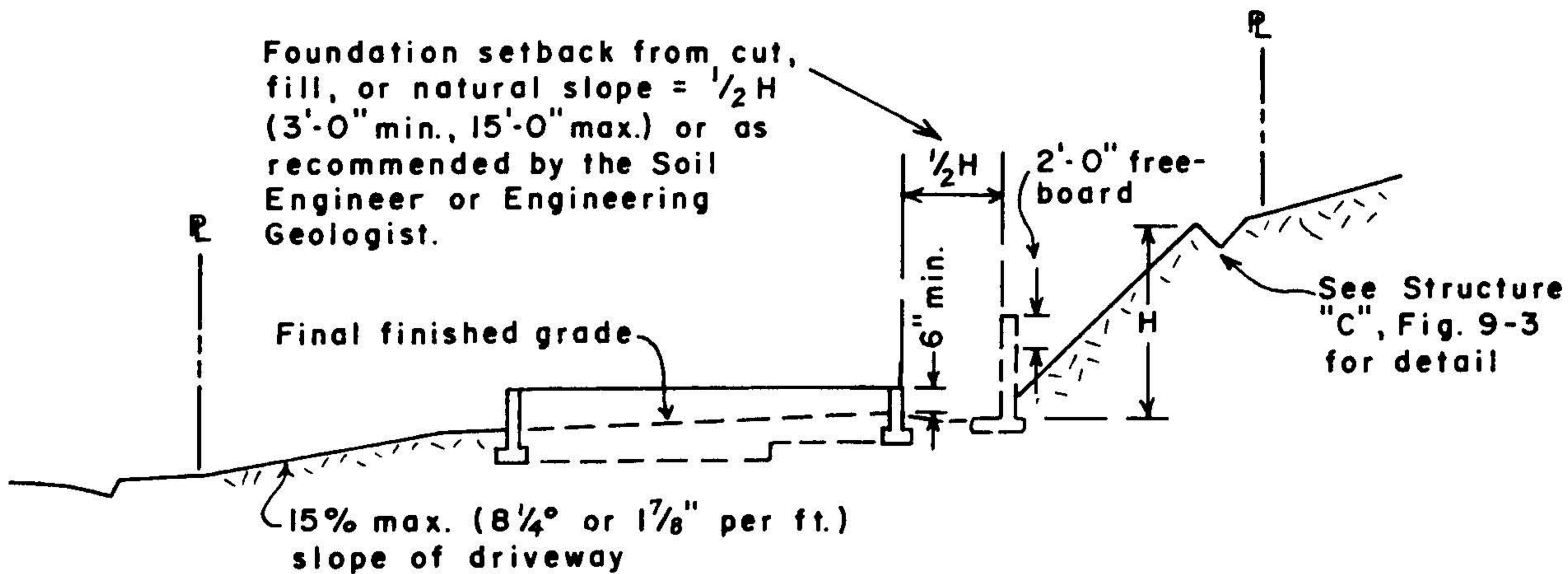

Figure 9-3 Recommended minimum drainage and setbacks relative to graded slopes. (Note: These differ from those in U.B.C. Chapter 70.)



DRAINAGE AND PLOT PLAN

Foundation setback from cut, fill, or natural slope = $\frac{1}{2}H$ (3'-0" min., 15'-0" max.) or as recommended by the Soil Engineer or Engineering Geologist.



NOTE: Where "H" exceeds 20'-0", provide 4'-0" high with 2'-0" freeboard, designed retaining wall at toe of slope if foundation is within 15'-0" of the toe of slope. Beyond 15' setback, wall may not be required unless recommended by the Soil Engineer or Engineering Geologist.

SECTION A-A'

STEPPED FOUNDATIONS: Foundations for all buildings where the surface of the ground slopes more than one foot in ten feet shall be level or shall be stepped so that both top and bottom of such foundation are level. Minimum step 4'. (1979 UBC - Section 2907 (c))

Source: Redrawn from County of Orange, CA.; minimum design recommended by Michael Scullin.

Figure 9-4 Recommended minimum grading for a typical hillside lot.

The Supervising Engineer shall provide a minimum of one blue top stake, set at the highest point in the finish drainage swale. The elevation of the floor shall also be provided to insure proper clearance and fall to drainage swale. These elevations shall be noted on the building plans and checked by the Plan Checker.

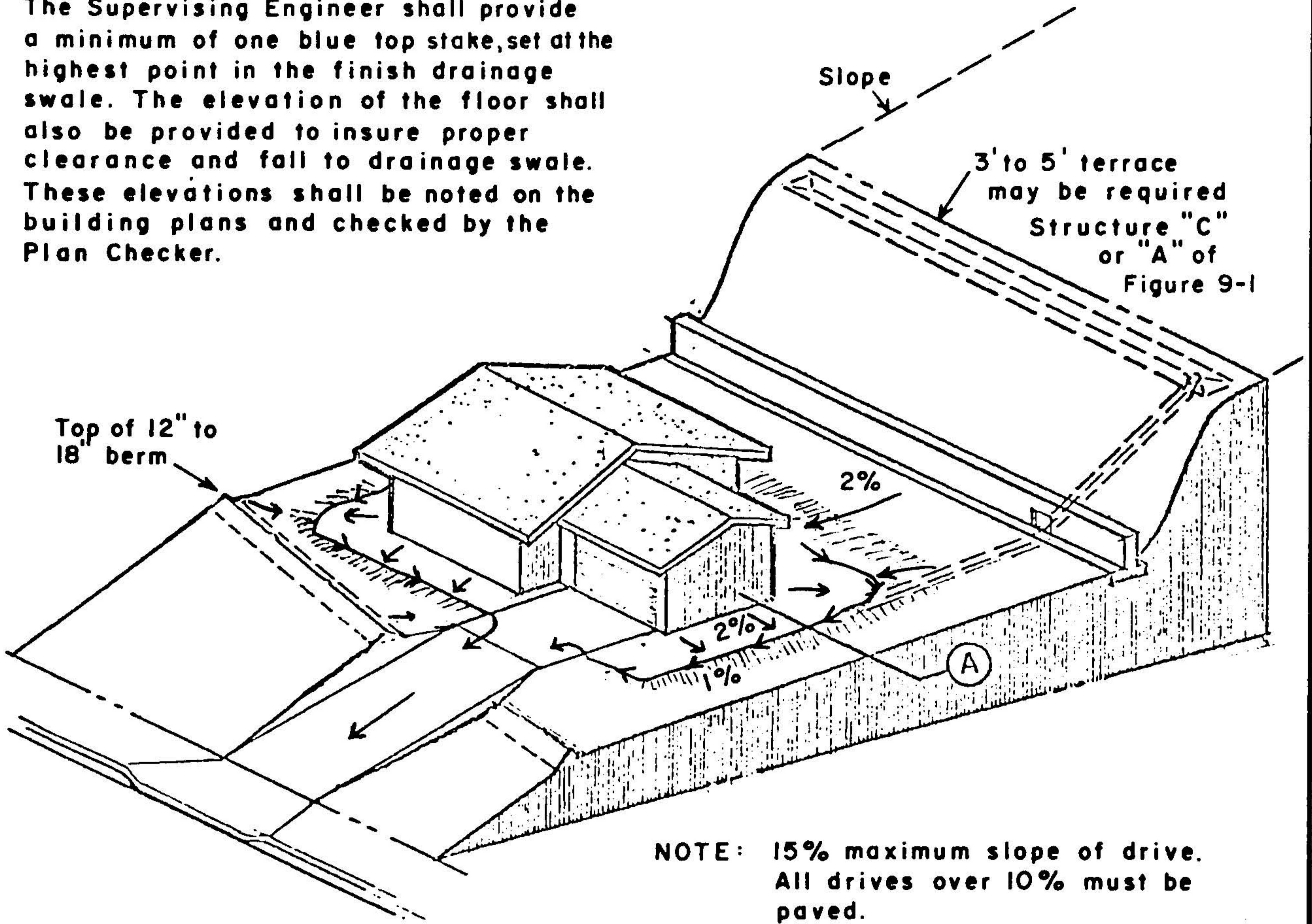

NOTE: 15% maximum slope of drive. All drives over 10% must be paved.

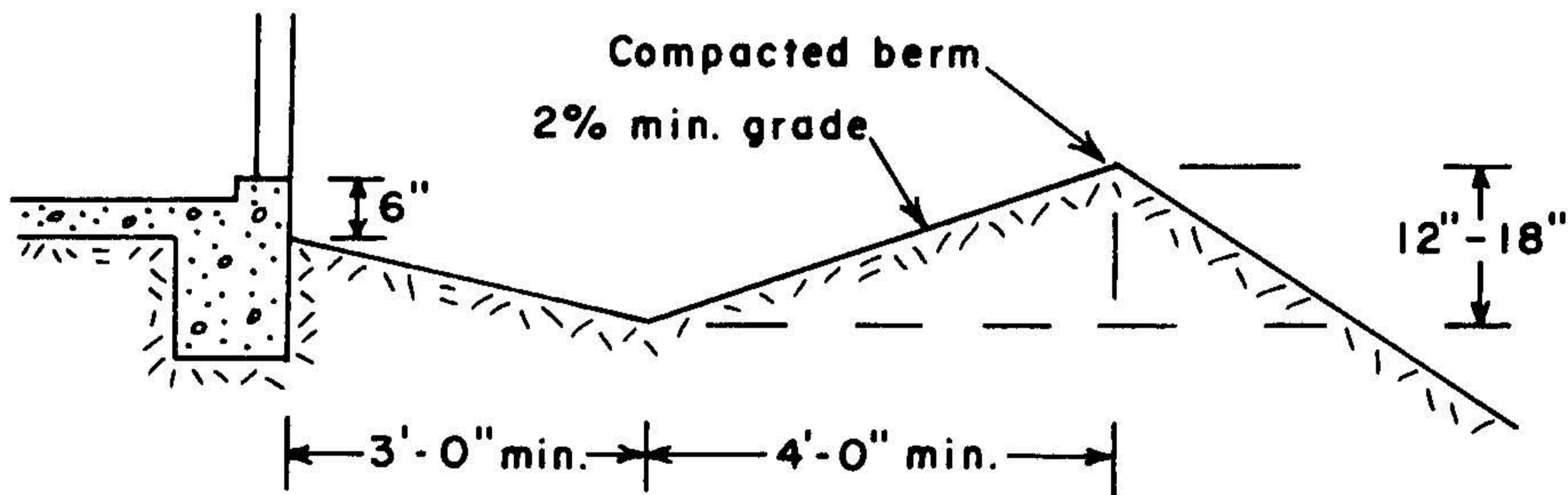

SECTION A - TYPICAL BERM AND SWALE

Where low sideyard area is less than 7' wide, drainage should be conducted to street in an improved device.

Common drainage swale may be used along sideyard property line where there is less than 1' difference in elevation between the lot pads.

Source: Redrawn from County of Orange, CA.

Figure 9-5 Recommended minimum grading of berms and drainage swales for a typical hillside lot.

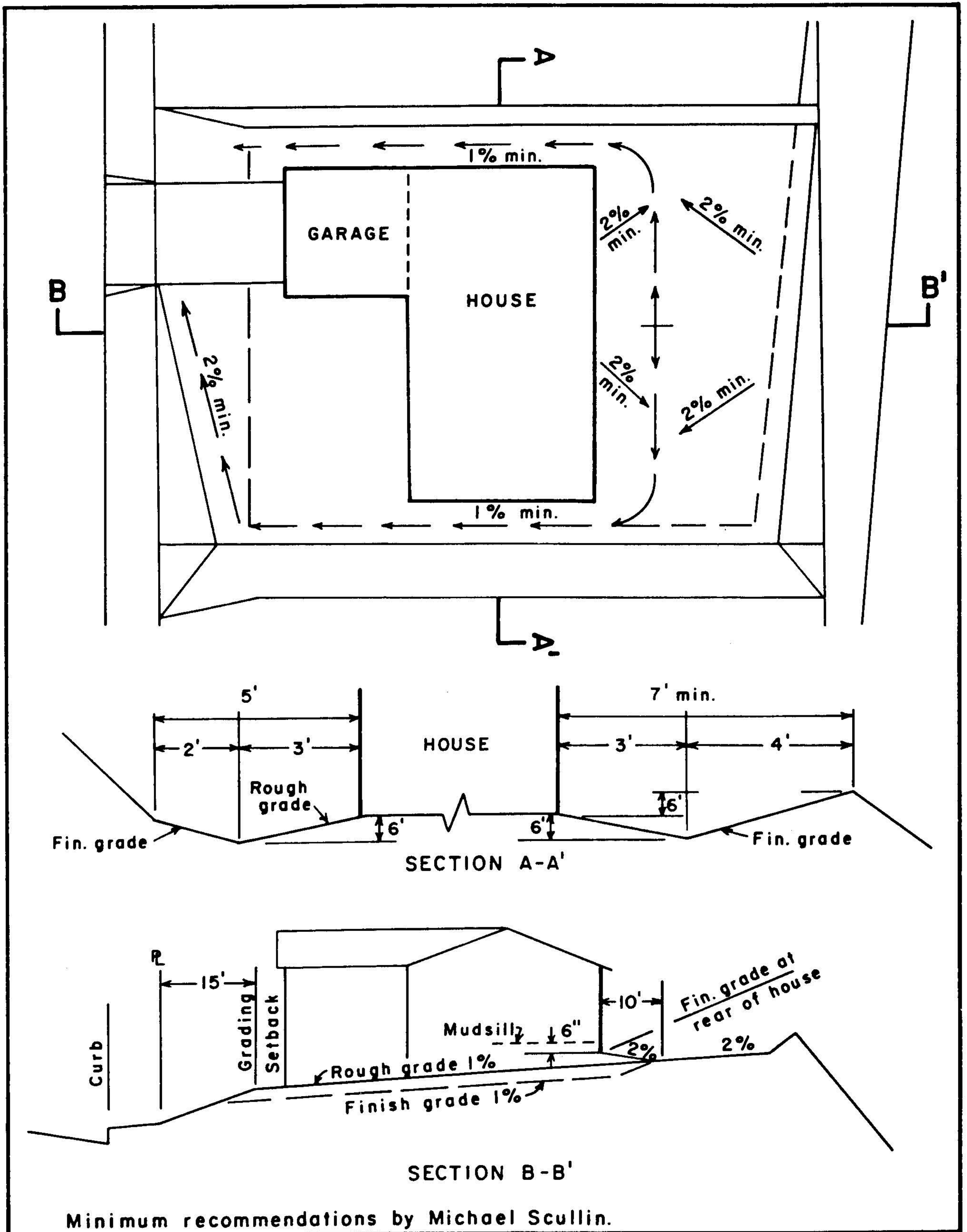

Figure 9-6 Minimum drainage swales and setbacks for a graded hillside lot.

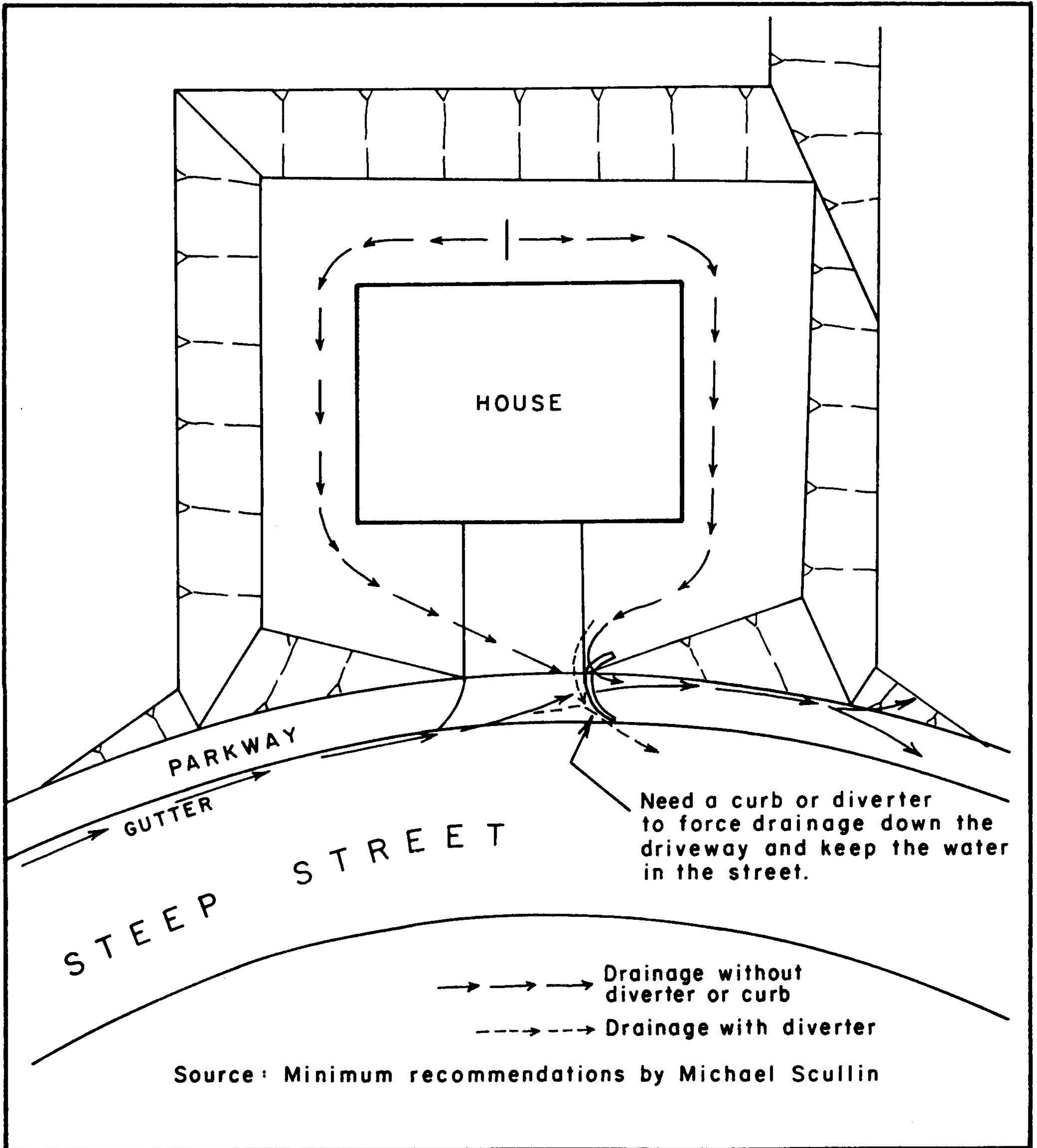

Figure 9-7 Hillside drainage problem on steep curved street (erosion of the parkway area).



Figure 9-8 Lot drainage onto a steep street. Notice the asphalt berm on the right side of the driveway to assure that drainage stays in paved area. Photograph by and courtesy of Alex Bruce, senior building inspector, City of Los Angeles.

Slope Drains

Some designers dislike the use of terrace drains and down drains, such as structures A and D in Figure 9-1, on the basis that they are unaesthetic. However, the main consideration must be erosion prevention and stability of the slope. Slope drains are necessary where graded slopes are composed of sedimentary-type rock or fill.

Terrace benches for constructing these drains should be at a maximum vertical interval of 30 feet to establish a realistic maximum exposed slope that can be planted and maintained without erosion for average conditions. The terrace drain gradient of 6% is necessary for the drain to be self-cleaning so as to reduce the need for owner maintenance since few hillside dwellers climb up or down slopes to clean these drains. (See Figures 9-9 and 9-10.)

There is generally a silting problem with newly graded slopes that lasts from 3 to 5 years until a substantial ground cover is established. In Southern California, the use of 6% gradient is recommended for better silt control and cleaning, as well as faster runoff. However, the Southern California area does not have the frequency of rains that other areas of the country experience, so long-term scouring action needs less consideration in this region than in wetter parts

of the country. Also, conditions that approximate steady flow may be more conducive to self-cleaning.

Adequate slope terrace drains (see structure A, Figure 9-1) are 5 feet wide, measured from the top of the slope horizontally to the flowline. They are paved with 3 inches of reinforced concrete or gunite and have a vertical depth of 18 inches. When paved at the back slope, the overall paved section is approximately 6.5 feet wide, which is adequate to handle most normal intensities of rainfall and most normal sloughing and soaking conditions. The 3-inch concrete or gunite should be reinforced with wire mesh or reinforcement bars to prevent or reduce cracking and to give the terrace drains longer life. (See Figures 5-63 to 5-78.) The depth of 18 inches, rather than 12 inches, provides more of a "V" to allow increased drainage velocity, which increases self-cleaning. It also provides more capacity in the event of blockage. Climatic differences discussed above also apply here. For long-term performance and easier maintenance, slope down drains (see Figure 9-1, structure D) should be open channel rather than pipe drains. Pipe drains, which commonly get plugged and fail, are often used because they can be hidden out of sight. However, out of sight, out of mind leads to lack of maintenance and, in time, to slope failure.



Figure 9-9 Colluvial soils and stream terrace gravel materials slumping and rilling into slope drains. These terrace slope drains have minimum gradients of 2%-4% which are insufficient for self-cleansing or removal of heavy slump materials. Photograph by C. Michael Scullin.



Figure 9-10 This terrace slope drain is too narrow and has a flat gradient of 2%. This type of terrace drain does not perform very well as it fills-in readily from siltation, and runoff overflows the drains to erode the slopes. Photograph by C. Michael Scullin.

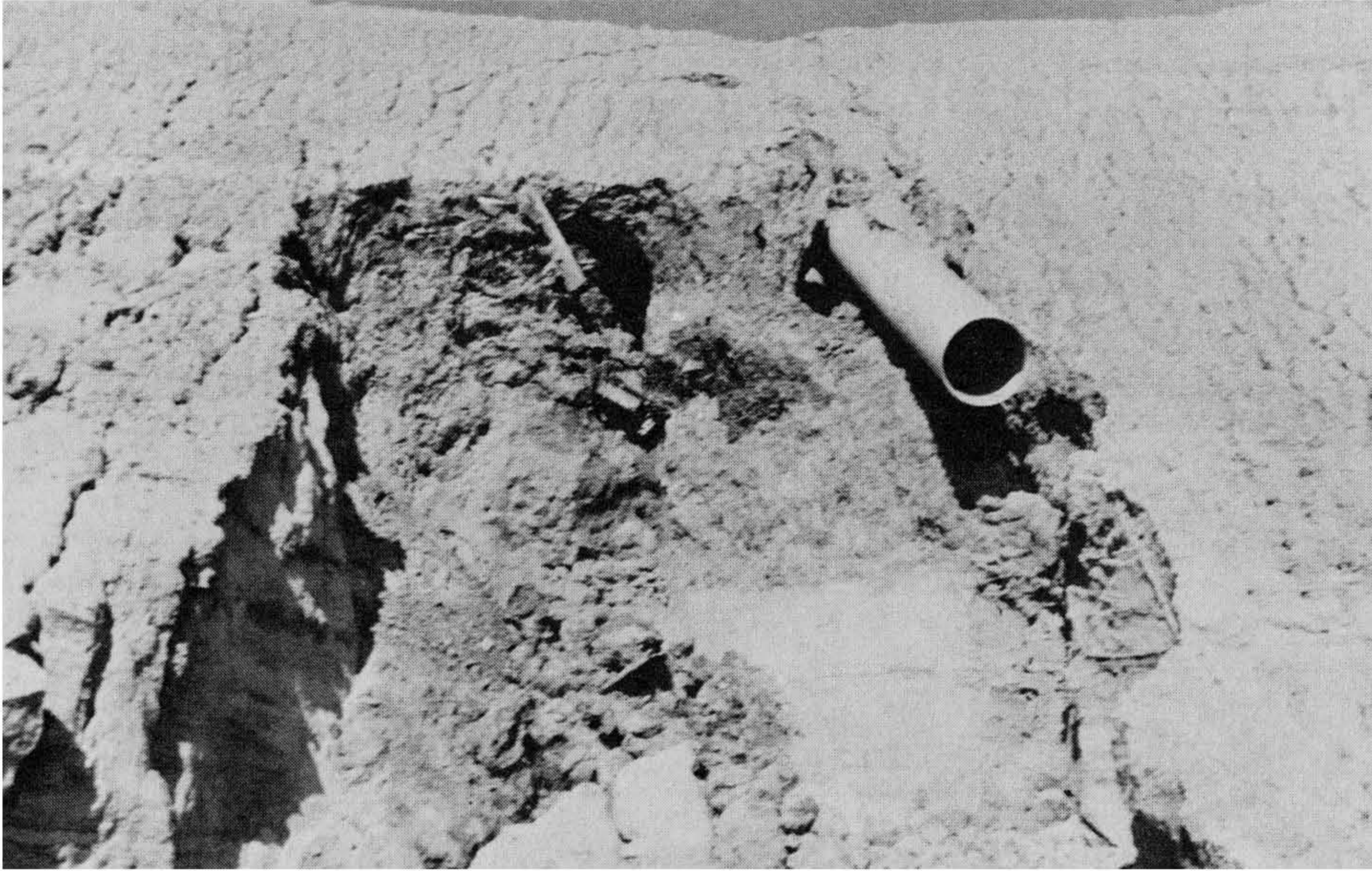

Figure 9-11 Water piping around the pipe down-drain has caused saturation and slope failure. An open channel down-drain would have performed better. Photograph by C. Michael Scullin.

Figure 9-12 Erosion around a pipe down-drain. Pipes have a tendency to get plugged due to lack of maintenance. Subsequent overflow erodes deep gulleys in the slope. Photograph by C. Michael Scullin.

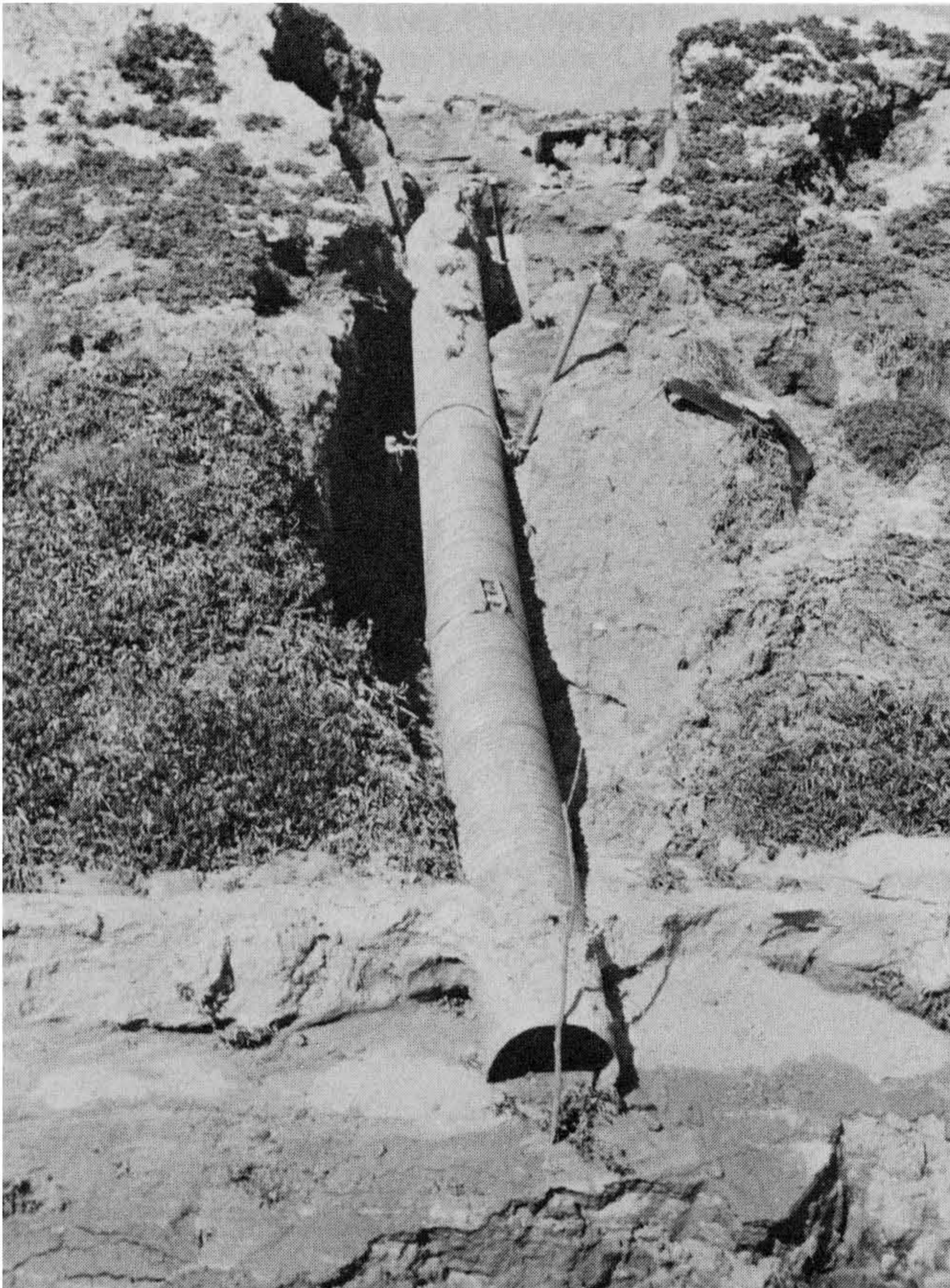

Figure 9-13 A pipe down-drain that has plugged up. The water has overtopped the slope and a gully has formed by erosion. An open channel down-drain would have performed better. Photograph by C. Michael Scullin.



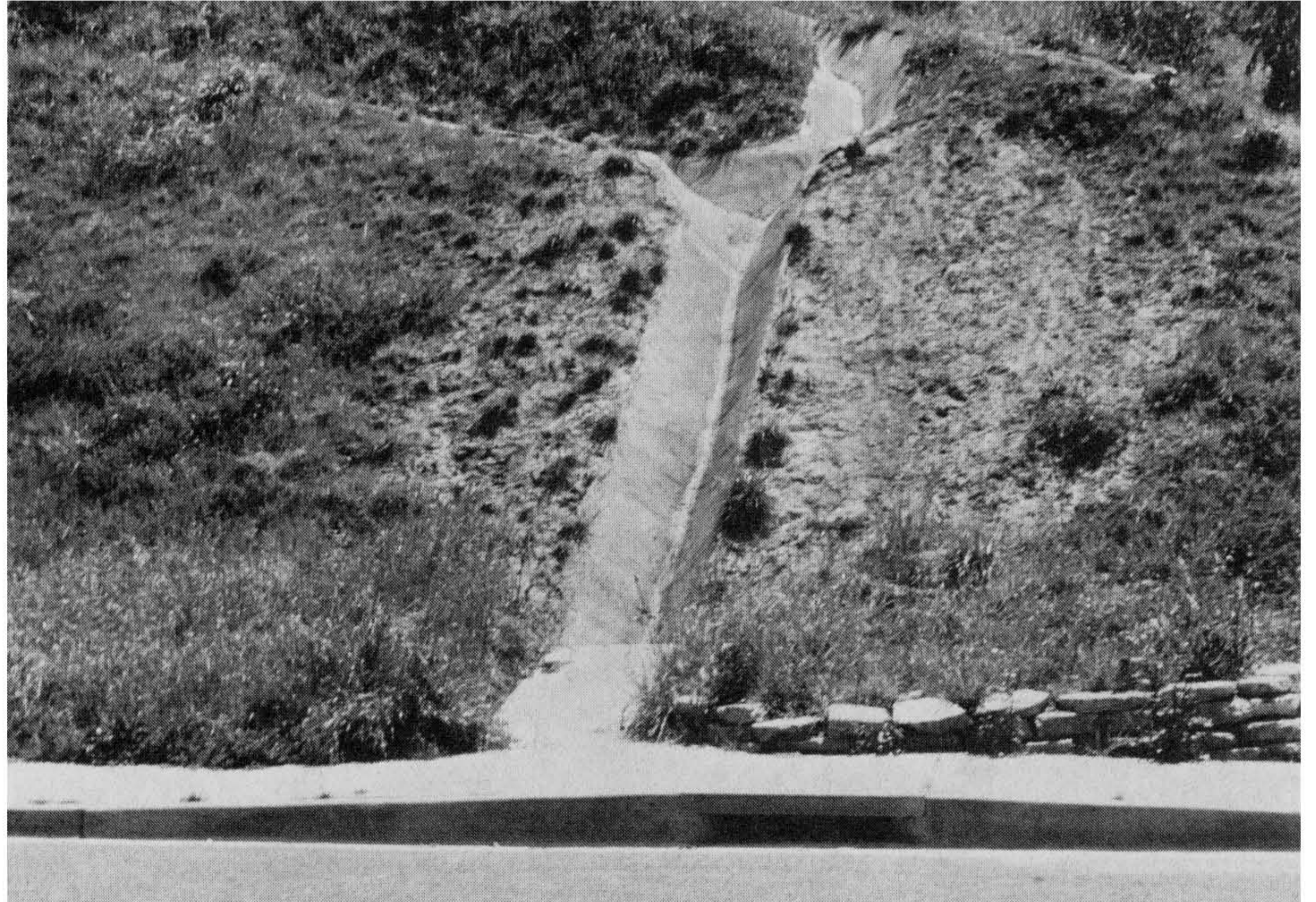

Figure 9-14 This brow-ditch drains along a top-of-slope drain into a paved down-drain and through the curb face into the street gutter. Photograph by C. Michael Scullin.

By limiting the length or run of terrace drains to 300 feet between down drains, the buildup of concentrated water and silt is also limited. When water flows down the down drain and meets the more level pad drain, the water will drop its silt load. If this silt load is considerable, it will cause problems on the building pads. (See Figures 9-2, 9-9 and 9-10.) If developers complain about the number of down drains required, we suggest that they use 600 feet between drains with a grade break in the middle in order to maintain an effective 300-foot interval between down drains. Developers may also complain that on steep

streets these down drains reduce pad areas by 5 feet; but if the drains overlap as the streets progress up the hill, this loss does not occur. (See Figure 9-2.)

If a deep canyon fill is proposed in a steep V-shaped canyon, the terraces should be split in the middle and drained toward the toe or daylight line. (See Figures 9-15 and 9-16. The daylight lines should be in the location of the down drains since the grading in essence forms a smaller, concentrated ravine at each side of the fill slope along the daylight lines. This plan will require raising the freeboard of the down drain with diverter walls at each terrace inlet



Figure 9-15 An engineered compacted fill in a V-shaped canyon with down-drains constructed along both daylight lines for good erosion control. Photograph by and courtesy of Robert W. Ross.



Figure 9-16 The deep V-shaped canyon fill in far right background has down-drains constructed along both daylight lines for better erosion control. Terrace drains are peaked in the center to drain both sides into down-drains. Photograph by and courtesy of Robert W. Ross.

to turn the water. (See bottom of Figure 9-2, and Figures 9-15, 5-77, and 5-78.) Riprap, or velocity reducers, should be provided to prevent headward erosion under the fill wherever the down drain discharges onto natural ground. Where a down drain discharges into a pad drain, a velocity reducer should not be used because it will cause the pad and drain to silt up. In this situation, the head and velocity are needed to carry the silt along the pad drain to the street or to the collector. Hillside lots with narrow side yards have a potential for erosion due to the diversion of drainage over the slope. (See Figures 9-17 and 9-18.) Depressed sidewalks can be used effectively as drainage devices in narrow side yard areas. (See Figures 9-19 through 9-21.) Retaining wall drains can also be utilized to help with drainage and erosion control.

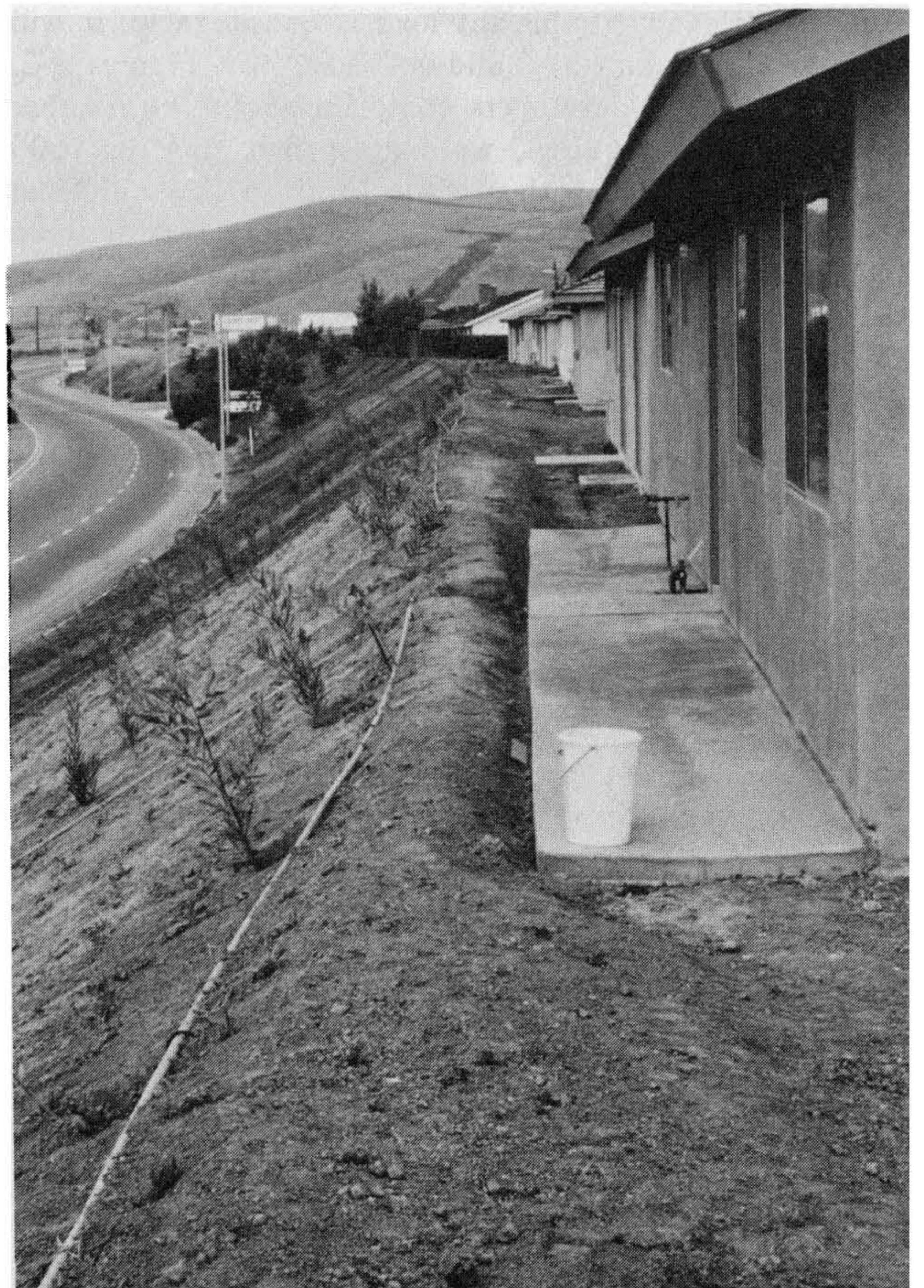

Figure 9-17 These residences built too close to this slope lack roof gutters and drainage to the front street. Eventually, this slope will erode or slump due to oversaturation and concentrated drainage over the slope. Photograph by and courtesy of Robert W. Ross.



Figure 9-18 Retaining wall construction along a mutual property line. Notice the close proximity of the residence foundations to the property line and the narrow sideyard. Photograph by and courtesy of Alex Bruce, senior building inspector, City of Los Angeles.

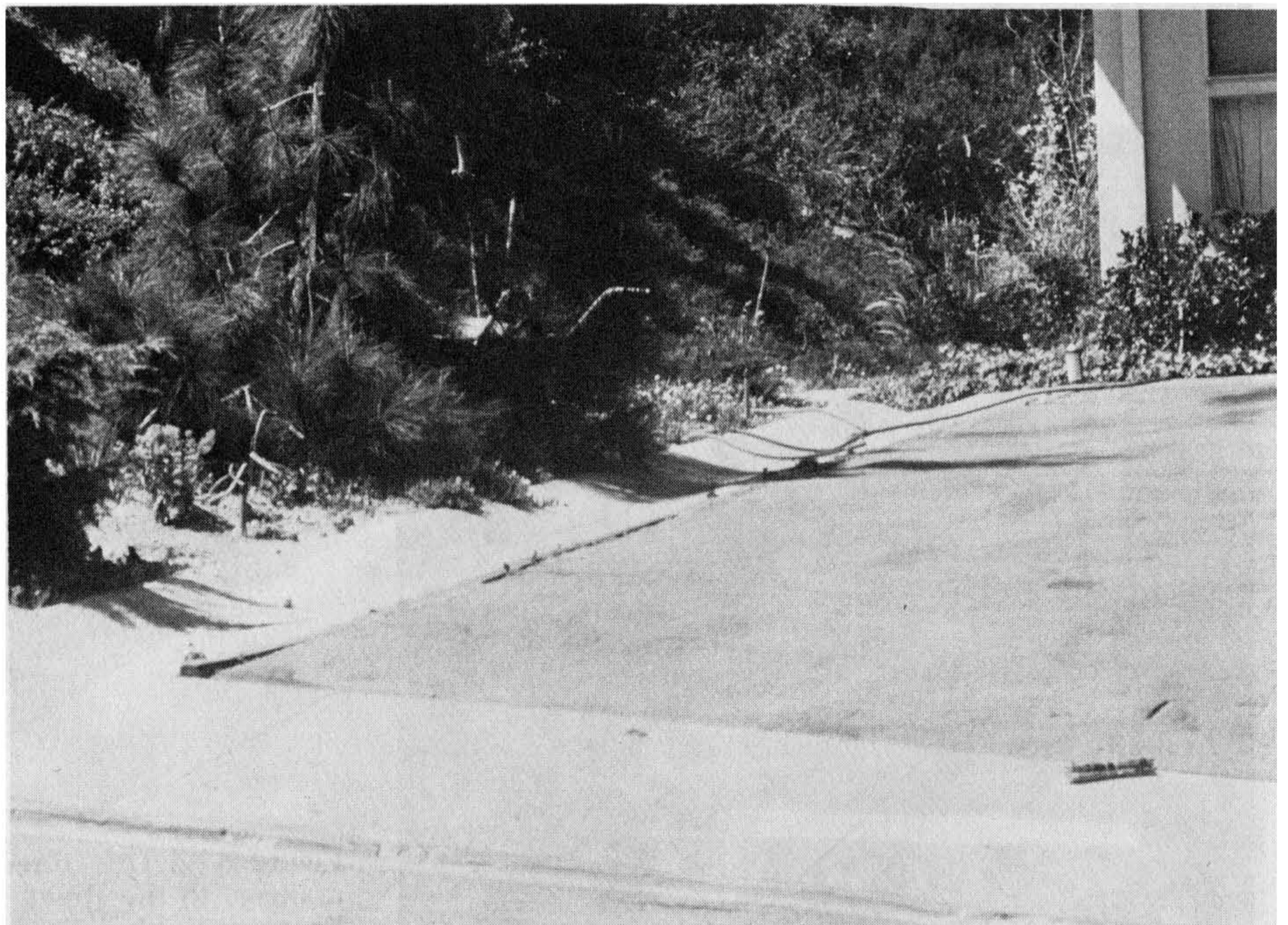

Figure 9-19 A paved drainage swale and/or depressed sidewalk carries drainage around the sideyard to the street. Photograph by and courtesy of Alex Bruce, senior building inspector, City of Los Angeles.

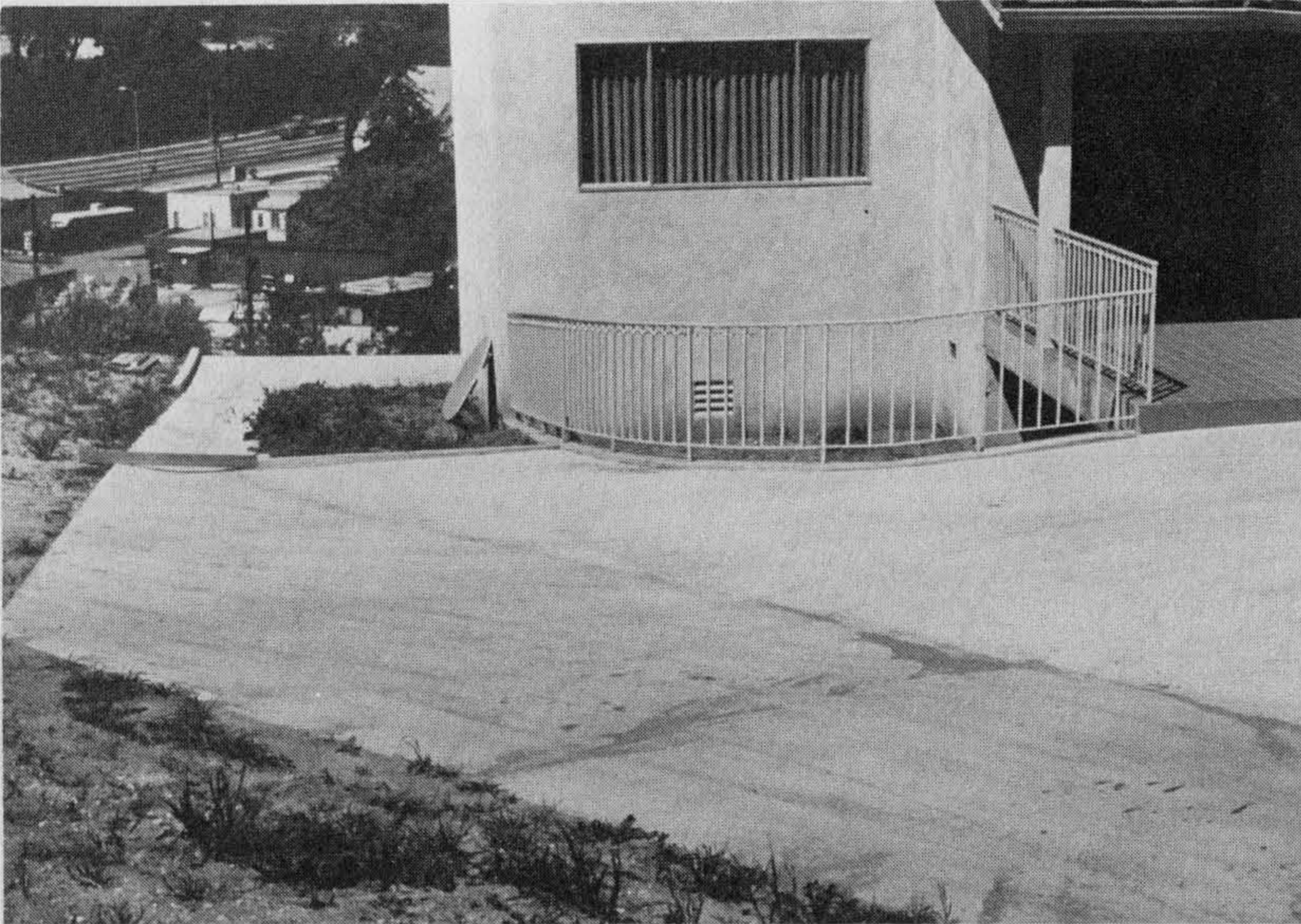

Figure 9-20 A sidewalk and driveway drain. The 2 X 4 in. board across the depressed sidewalk drain illustrates the flowline swale. Photograph by and courtesy of Alex Bruce, senior building inspector, City of Los Angeles.

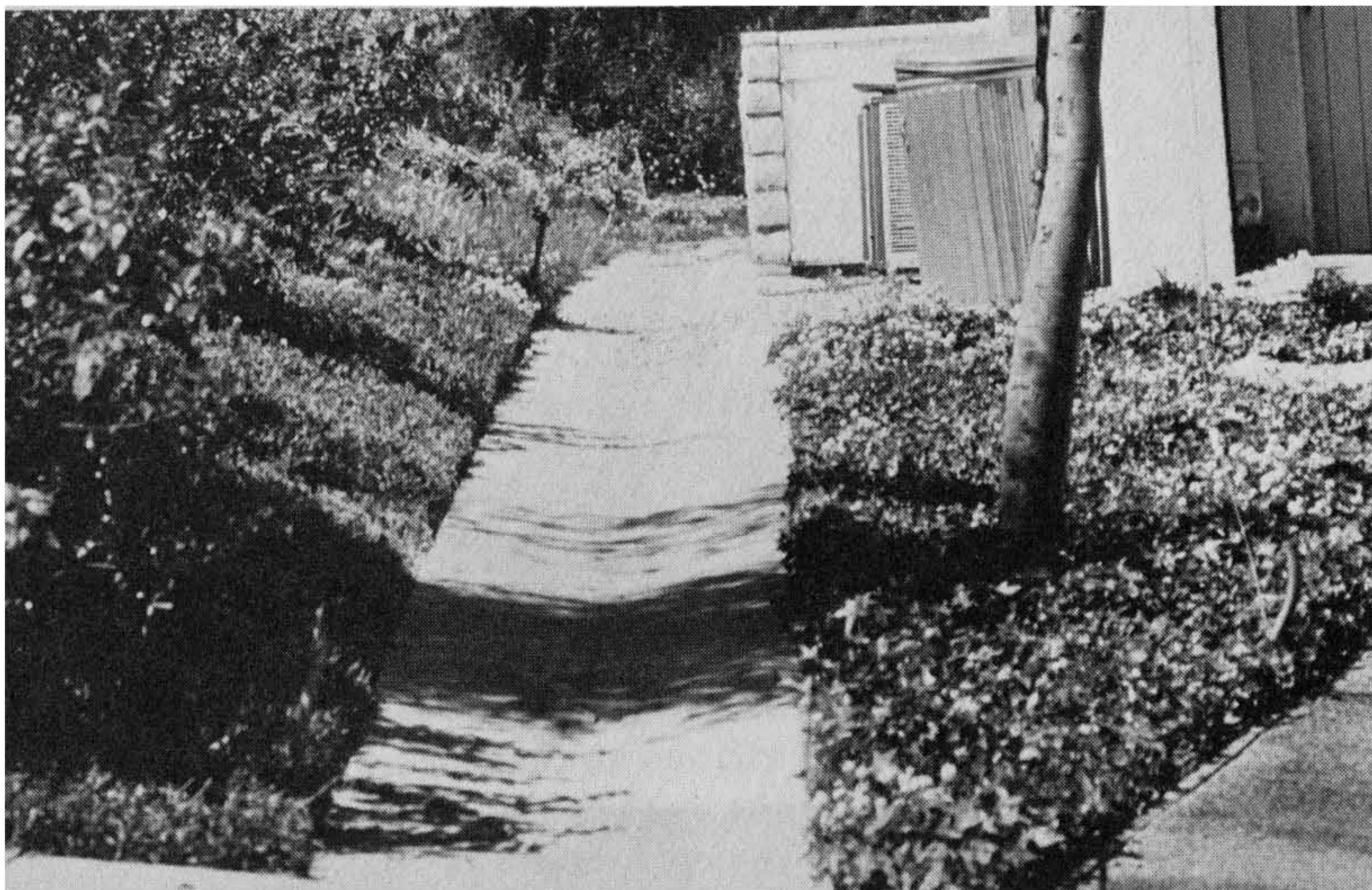

Figure 9-21 Here a depressed sidewalk drain carries drainage from the rear yard to the street. Photograph by C. Michael Scullin.



Planting for Erosion Control

Planting of both cut and fill slopes as a controlling factor against the natural forces of wetting, drying, and wind and water erosion has been accepted as a permanent and pleasant method of reducing erosion. Planting approved vegetation compatible with the climate, soil, and site conditions is important.

A major problem which arises is that of providing adequate maintenance. Enforcement of required maintenance by the developer for a period of time, or by some other entity, can be adequate only if other requirements of the code are adhered to and enforced.

Figure 9-22 This tilted sidewalk drain carries rear yard drainage to the street. Photograph by and courtesy of Alex Bruce, senior building inspector, City of Los Angeles.

Figure 9-23 Here a gunited drainage swale has been constructed behind a retaining wall. The gunite has been extended partially up the slope to fill in an eroded slump. Photograph by and courtesy of Alex Bruce, senior building inspector, City of Los Angeles.

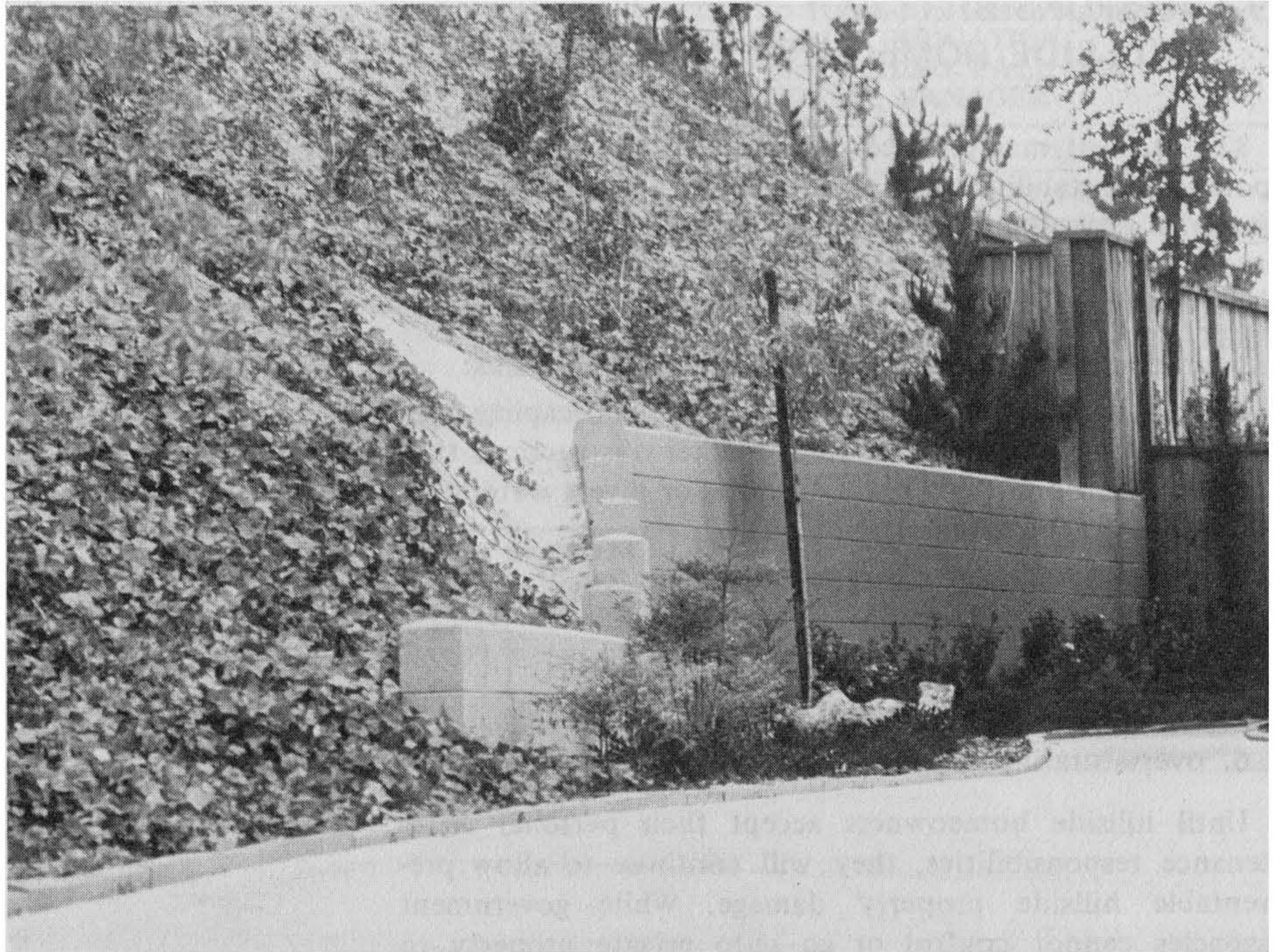

While specific maintenance/watering suggestions are elaborated in Section 9-4, it is important to note here that a current practice of requiring automated sprinkling systems for planted slopes can create serious overwatering problems, including slope failures. Slopes that are watered daily, especially by the use of automatic timing devices, are frequently oversaturated long before the rains come, and have a tendency to fail during the increased satura-

tion during rainy periods. Such timing devices cause the sprinklers to function even during rainstorms! This type of abuse must be considered by governmental agencies that now require automatic sprinkling of cut and fill slopes. Manual operation of sprinklers should be considered as an alternative. (See Figure 9-24.) Further discussion of planting is provided in Section 9-5.

Figure 9-24 Checking sprinkler heads and "rainbird" performance. Close maintenance of watering devices is necessary to minimize oversaturation. Photograph by and courtesy of Alex Bruce, senior building inspector, City of Los Angeles.



9-3 RESPONSIBILITY OF THE HILLSIDE HOMEOWNER

The lack of maintenance of hillside sites is a source of potential instability that governmental agencies and professional consultants are unable to control. The government and professional consultants cannot protect the homeowner from himself. The homeowner creates problems by:

1. neglecting to maintain hillside slope and lot drains;
2. changing the lot drainage pattern by landscaping, construction of patios, stoops, or other obstructions that dam and pond lot drainage swells or divert water over slopes;
3. removing the lateral support of the toe of slope to create more pad area;
4. neglecting to clean out roof eaves and gutters;
5. failing to clean out behind slough structures;
6. oversaturating slopes by excessive landscape watering.

Until hillside homeowners accept their personal maintenance responsibilities, they will continue to allow preventable hillside property damage. While government agencies cannot control or go onto private property to maintain the drainage, erosion control, and protective devices installed by developers, they can help developers educate hillside homeowners in correct maintenance procedures for both rainy and dry periods.

Several studies have been conducted to determine irrigation water practices by hillside homeowners in Southern California. One study, conducted by Leroy Crandall Associates [1], investigated landscape water consumption from 1975 through 1978 of four tracts and three parks in the County of Orange, California. This study indicates that the lot owners used from a low of 15.6 inches to a high of 123.6 inches of water per year per lot for an average of 54 inches of irrigation water per year per lot in their landscape watering. (See Table 9-1.)

Glenn A. Brown, Chief Engineering Geologist, Leroy Crandall and Associates, participated in the State of California Water Rights Board staff study of water use in the San Fernando Valley area of Los Angeles County. The results [2], shared recently in personal communication between Mr. Brown and the author, indicate that the average hillside homeowner in the Los Angeles area studied had used the equivalent of 50 to 75 inches of water per year per lot in landscape watering. Annual average rainfall in the Los Angeles area varies from 15 to 20 inches a year. Annual rainfall (15 to 20 inches per year) added to the residential water application for landscape irrigation of 50 to 75 inches per year, increases the water application from 65 inches to 95 inches of rainfall per year per lot. Adding the annual rainfall of 15 to 20 inches to the Orange County study results in the water application increasing from approximately 25.6 inches to 143.6 inches of water per year per lot. This water application in many cases exceeds natural rainfall recorded in most natural water basins throughout the world and creates a rain-forest environment in a semi-arid climate. Most local vegetation does not need, and often cannot tolerate, the amounts of water applied.

TABLE 9-1 WATER APPLIED FOR IRRIGATION

Tract	Lot	Total Applied Water in Feet ¹			
		1975	1976	1977	1978 ²
6511	Water Problems Reported				
	4	3.6	2.9	1.3	2.6
	9	4.6	7.4	4.8	2.4
	13	3.8	4.9	3.6	4.2
	28	4.5	4.9	2.9	4.7
	36	1.8	2.0	1.2	1.6
	37	4.1	3.8	2.6	2.8
	41	8.2	9.6	9.6	6.7
	66	10.0	10.3	6.0	4.6
	82	8.8	6.3	4.5	5.0
	Water Problems Not Reported				
	33	0.9	1.4	0.9	1.7
	46	6.1	5.4	3.5	4.4
	51	3.7	3.3	2.5	3.1
72	2.6	1.2	0.9	1.7	
6287	Water Problems Reported				
	5	1.4	2.3	1.3	2.7
	10	2.3	2.8	1.4	2.3
	2	4.2	7.3	4.9	5.0
	Water Problems Not Reported				
78	3.8	2.5	1.6	4.2	
18	1.6	1.1	0.8	1.5	
6599	Water Problems Reported				
	46	1.8	1.9	0.9	2.0
	11	1.2	0.8	0.8	1.7
	Water Problems Not Reported				
8	3.0	3.2	2.5	4.5	
34	1.5	1.5	1.3	2.1	
6600	Water Problems Reported				
	29	2.9	2.7	2.4	2.7
	47	3.3	3.6	3.1	3.2
	42	4.1	5.2	3.3	3.3
	Water Problems Not Reported				
	13	2.1	1.8	2.2	2.1
1	1.5	1.6	0.9	1.8	
Parks					
Mt. View		5.5	6.3	5.8	6.4
Turtle Rock		6.1	5.2	3.9	6.6
Grossmont		6.9	7.2	6.9	6.6

¹Multiply the applied water in feet by 12 inches to provide equivalent inches of rainfall per year per lot.

²Applied water for 1978 does not include November and December.

Source: Glenn A. Brown, LeRoy Crandall and Associates.

With such abuse to either man-made or natural slopes, we cannot expect stable slope performance. In fact, over 80% of the near-surface slope failures involving the upper one to four feet of the slope faces investigated by the author during the heavy rainy periods of 1962, 1969, 1978, and 1980, were caused by oversaturation by sprinklers in combination with heavy rains.

Despite this documented evidence regarding automated overwatering as a cause of slope failures, and despite indications that some planning commissioners may reduce or minimize such requirements, many hillside tract developers are still required to establish irrigation systems with timing devices to initiate germination.

One promising method of reducing slope failures has been developed by Ron Pecoff of Escondido, California. To improve slope coverage Mr. Pecoff is encouraging the use of native plants that require minimal water and are fire resistant. In a test plot of native vegetation at Mission Viejo, California, through the cooperation of the Mission Viejo Company, water application was reduced from the equivalent of 50 inches of rainfall per year to the equivalent of

14 inches of rainfall per year, with a 200% increase in germination and growth. This reduction of water use is a cost savings to the consumer as well as an increase in plant growth. (See Figure 9-25.)

States having long, dry growing seasons are developing the use of drip watering for irrigation purposes. The drip-trickle method of irrigation used in California has been shown to save water and to increase vegetation growth as well.

Table 9-2, provided by the California Division of Mines and Geology [3], shows the accumulated yields of tomatoes grown by the drip-trickle irrigation method versus the furrow irrigation method. This table indicates increased marketing of tomatoes in tons per acre using the drip method. Increasing use of the drip method in hillside landscaping also has shown encouraging results.

TABLE 9-2 STAKED TOMATOS GROWN USING DRIP VS. FURROW IRRIGATION, COZZA RANCH, SAN YSIDRO, FALL 1970, TOSH HASEGAWA, MANAGER

Accumulated Yields from 1/70 to:	Yield Item	Irrigation Method	
		Twin-Wall Hose Drip	Furrow
10/15/70	Marketed Fruit in Tons/Acre	14.0	12.0
11/12/70	Marketed Fruit in Tons/Acre	28.1	22.8
12/16/70	Marketed Fruit in Tons/Acre	33.7 ¹	26.5
	Acre Feet of Water Used Per Acre	2.6	3.9

¹Highly significant.

Source: Copied directly from CDMG, *California Geology* (Nov. 1978), p. 267.

Figure 9-25 A well-compacted fill slope with all drainage devices functioning and minimum water applied. This slope has performed well through three heavy rain seasons. Photograph by C. Michael Scullin.



Education of Homeowners

While using native vegetation and manually operated drip systems will help to assure stabilization of hillside developments, there is also an intense need to educate hillside property owners about how to plant, irrigate, and maintain their properties. Increasingly, hillside developers are creating public awareness and public education programs to inform property owners about their responsibilities in maintaining hillside properties. Some developers are requiring buyers of residential or commercial properties to sign descriptive handout sheets regarding lot and slope maintenance. They are also sending letters to lot purchasers detailing recommendations regarding slope planting, landscaping, and drainage. Some developers are writing this information into their declarations of intent or their establishment of tract easements, conditions, covenants, restrictions, and reservations. Others are establishing maintenance districts within their tracts to ensure proper slope and drainage maintenance. But because maintenance district abuses in some cases have overshadowed the benefits, maintenance districts in themselves are not always satisfactory. So far, the best method of assuring slope stability has been to instruct hillside property owners how to maintain their sites. Such instructions appear in Section 9.4.

Some building officials have initiated public information programs regarding hillside living. These include:

1. providing illustrated lectures to hillside homeowner groups;
2. providing handout sheets to the public;
3. stapling a card of recommended do's and don't's in hillside maintenance in the garages of newly constructed residences;
4. having a well-organized operation readied for every rainy season to provide service to the public and the industry and to minimize problems (see Chapter 7);
5. working with city or county fire departments to have sand bags available at a reasonable cost for temporary erosion-control purposes;
6. having emergency information available at the public counter, by telephone, or through the news media, prior to the rainy season every year.

While the building industry and government officials strive to provide homeowners with the safest, most economical building sites possible with current knowledge and technology, there remains a need for homeowners to exercise common sense, good judgment, and sound maintenance practices in keeping their hillside homesites safe. This can best be assured when developers and government agents work together with homeowners from planning stages through long-term site use to achieve their all-important maintenance goals.

9-4 THE DO'S AND DON'T'S IN HILLSIDE LIVING

This discussion of maintenance of hillside homesites for slope stability and erosion control is provided by George Larson, Chief Engineering Geologist of GeoSoils, Inc., of Van Nuys, California [4]. GeoSoils makes this material available to clients who purchase hillside homes. Similar information should be supplied to all hillside property purchasers, and should also be broadcast by news media prior to and during annual rainy seasons to inform or remind hillside property owners about how to maintain their properties safely.

During the wet weather season, homeowners living in houses placed on fill (man-placed earth) or in the vicinity of excavated (cut) or fill slopes, become concerned about the condition of their building sites. In general, modern design and construction practices minimize the likelihood of serious landsliding (slope failure). The grading codes of the local jurisdictions (cities and counties) in California concerning filled land, excavation, terracing, and slope construction are among the most stringent in the country. In addition, most hillside developments have been constructed according to critical professional standards. Therefore, the concern of the homeowner should be directed toward maintaining slopes, drainage provisions, and facilities so that slopes will perform as designed. The following general recommendations and simple precautions are presented to help guide in the maintenance of hillside homesites. Please refer to the attached diagram (Figure 9-26) for an illustration of terms.

In general, the public regards the natural terrain as stable—"terra firma." This is, of course, an erroneous concept. Nature is always at work altering the landscape. Hills and mountains are worn down by mass wasting (erosion, landsliding, and creeping soil) and the valleys and lowland areas collect these products. Thus this natural weathering process leans toward leveling the terrain. Periodically (over millions of years), major land movements rebuild mountains and hills, and the leveling processes begin over again. In some areas these processes are very slow; in others they occur at a relatively rapid rate.

Current development of hillsides for residential use is carried out, insofar as possible, to enhance the natural stability of the site and to minimize the probability of instability resulting from the grading necessary to provide homesites, streets, and yards. This has been done by the developer and designers on the basis of geologic and soil engineering investigations. However, in order for the design to be successful, the slope and drainage provisions, and the facilities must be maintained by the homeowner.

Homeowners are accustomed to maintaining their homes; that is, they expect to paint periodically, to clean out clogged plumbing, to repair roofs, and so on. Maintenance of a hillside homesite must be considered on an even more serious basis because neglect can result in serious consequences. In most cases, lot and site maintenance can be

TERMS USED WITH HILLSIDE HOMESITES

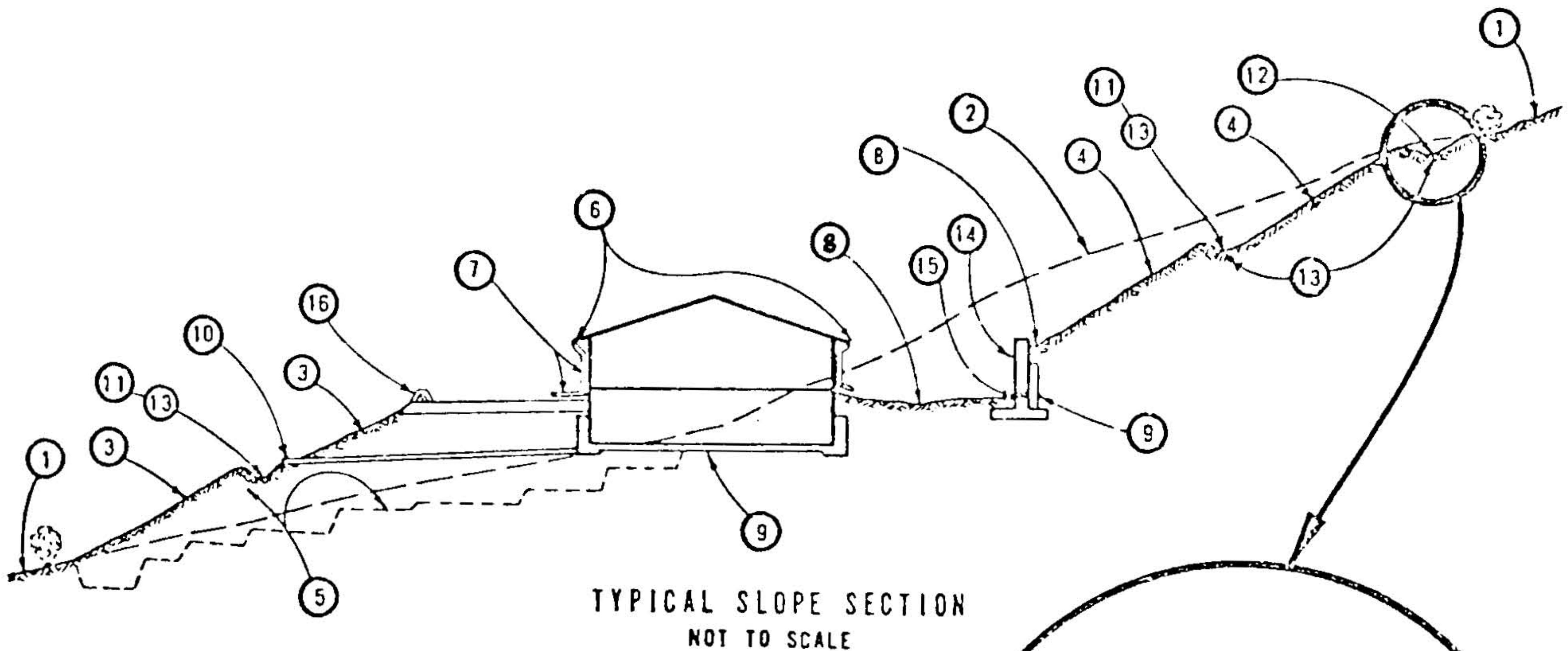

NOTATIONS:

- ① NATURAL GROUND SLOPE
- ② ORIGINAL GROUND SURFACE
- ③ FILL SLOPE
- ④ CUT SLOPE
- ⑤ FILL COMPACTED TO ENGINEERING SPECIFICATIONS AND BENCHED INTO FIRM GROUND.
- ⑥ ROOF GUTTER
- ⑦ DOWNSPOUT CONNECTED TO AN UNPERFORATED PIPE OR LINED DITCH WATER COLLECTION SYSTEM.
- ⑧ DRAINAGE SWALE OR DITCH
- ⑨ SUBDRAIN (PERFORATED PIPE AND/OR PERMEABLE MATERIAL).
- ⑩ SUBDRAIN DISCHARGE (UNPERFORATED PIPE).
- ⑪ DRAINAGE TERRACE AND DITCH (SEE DETAIL)
- ⑫ BROW DITCH
- ⑬ LINED DRAINAGE DITCH (SEE DETAIL)
- ⑭ RETAINING WALL
- ⑮ WEEP-HOLES THROUGH RETAINING WALL
- ⑯ BERM TO DIRECT WATER OFF SLOPE

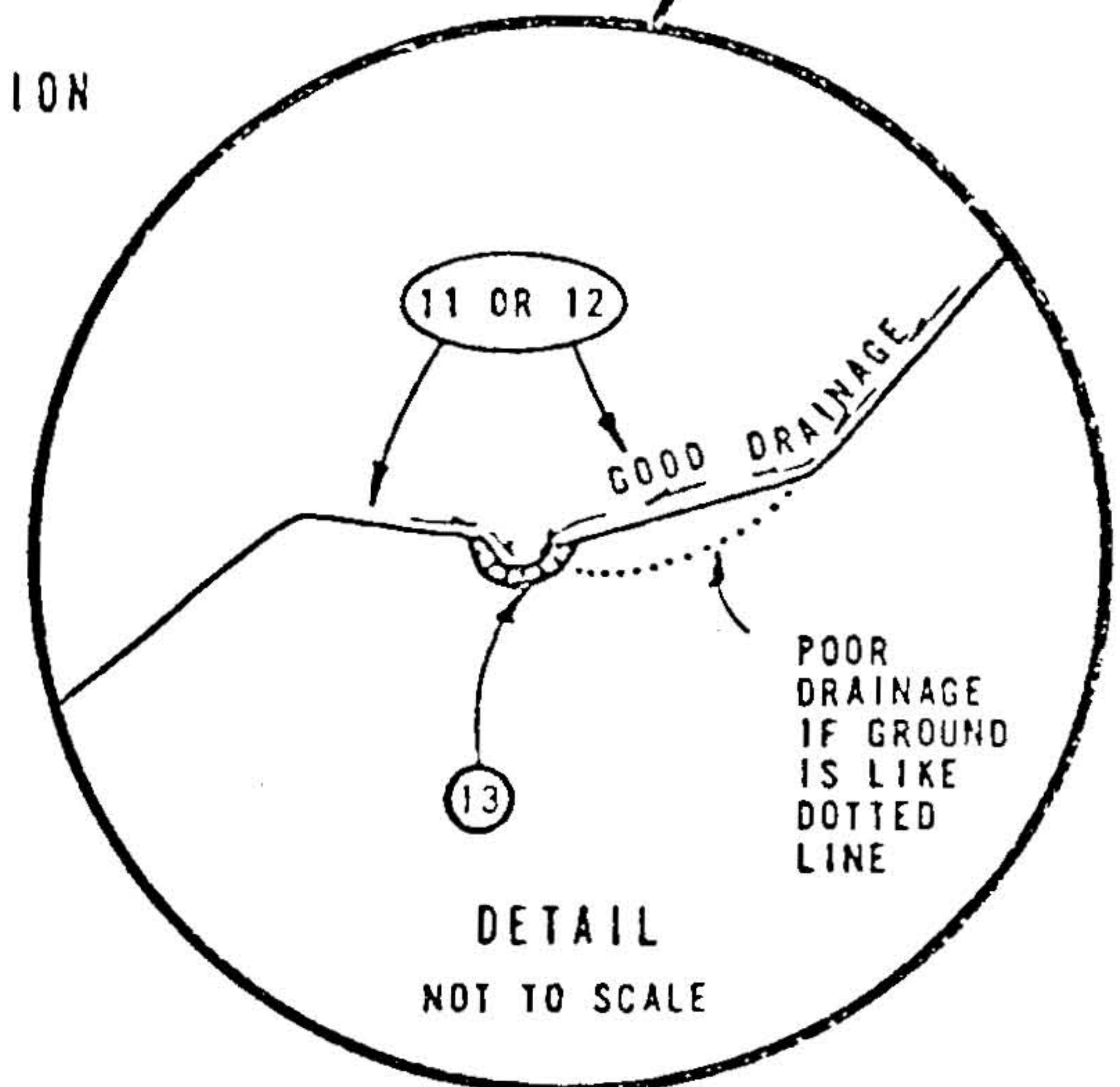

Source: Mr. George Larson, Chief Engineering Geologist, GeoSoils, of Van Nuys, CA.

Figure 9-26 Terms used to describe site conditions at hillside homes.

provided along with normal care of the grounds and landscaping. Any costs of maintenance are likely to be less than the costs of repair after neglect.

Most hillside lot problems are associated with water. Uncontrolled water from broken pipes, septic tanks, excess landscape watering, or wet weather causes the most damage. Most problems occur during wet weather, especially during torrential or prolonged rains. Therefore, drainage and erosion control are important aspects of homesite stability, and the provisions built into the developed lot must not be altered without competent professional advice. Maintenance of the provisions must be carried out to assure their continued operation. Therefore, we offer the following list of "Do's" and "Don't's" as a guide:

DO

1. Check roof drains, gutters, and downspouts to be sure they are clear. Depending on location, houses may not have roof gutters and downspouts. These should be installed because roofs and their wide space can shed tremendous quantities of water. Without gutters or other adequate drainage provisions, water falling from the eaves collects against the foundation and basement walls, which is undesirable.
2. Clear drainage ditches and check them frequently during the rainy season. Neighbors should be asked to do likewise.
3. Check interceptor (brow) ditches at the top of slopes to be sure that they are clear and that water will not overflow the slope, causing erosion.
4. Be sure that all drain outlets and weep-holes are open and clear of debris, vegetation, and other material that could block them in a storm. If blockage is evident, have it cleared.
5. Check for loose fill above and below the property if it is on a slope or terrace.
6. Limit watering and stop watering altogether during the rainy season when little irrigation is required. Over-saturation of the ground can cause major slides and subsurface damage.
7. If landscaping on the slopes is changed, disturb the soil as little as possible and use drought-resistant plants that require a minimum amount of landscape irrigation.
8. Watch for water backup inside the house at sump drains and toilets since this indicates drain or sewer blockage.
9. Watch for wet spots on the property. These may be natural seeps or an indication of a broken water or sewer line. In either case, obtain competent advice regarding the problem and its correction.
10. Exercise ordinary precaution. The house and building site were constructed to meet standards that should protect against most natural occurrences, provided they are maintained.

DON'T

1. Don't over-irrigate slopes or leave a hose running or sprinkler unattended on or near a slope. Ground cover and other vegetation does require moisture during hot summer months, but during the wet season, irrigation can cause the ground cover to pull loose. This not only destroys the cover, but also starts serious erosion.
2. Don't alter lot grading without competent advice. The man-made slopes on the lot were designed to carry away water runoff to a place where it can be safely distributed.
3. Don't block or alter ditches that have been graded around the house or the lot pad. These shallow ditches have been put there for the purpose of quickly removing water toward the driveway, street, or other positive outlet.
4. Don't block or alter ditches or drains. If several homes rely on the same facilities, it is a good idea to check with neighbors. Water backed up on their property may eventually reach the homeowner's property. Water backed up in surface drains will overflow and infiltrate slopes, which leads to instability. Maintain the ground surface upslope of lined ditches to ensure that surface water is collected in the ditch and is not permitted to collect behind or flow under the lining. (See the detail sketch in Figure 9-26.)
5. Don't permit water to collect or pond anywhere on the lot. Such water will either seep into the ground and cause unwanted saturation, or will overflow onto slopes and begin erosion. Once erosion is started, it is difficult to control, and severe damage may result rather quickly.
6. Don't direct water over slopes even where this may seem a good way to prevent ponding. This tends to cause erosion and slope instability. Dry wells are sometimes used to get rid of excess water when other means of disposing of the water are not readily available. However, such facilities should be planned and located by a qualified engineer since dry wells transport surface water into the deep subsurface and may cause landslides.
7. Don't let water pond against foundations, retaining walls, and basement walls. These walls are built to withstand the ordinary moisture in the ground and, where necessary, are accompanied by subdrains to carry off excess subsurface water. However, excess surface water must be directed away from these structures.
8. Don't connect roof drains, gutters, or downspouts to existing subsurface drains that may not have been designed for that purpose. Instead, collect the water in lined ditches or unperforated pipes and conduct it to a storm drain, paved road, or a suitable area of natural ground. Where such channel flow is directed onto natural ground, it must be converted to sheet flow unless a suitable natural channel exists.

9. Don't discharge surface water into septic tanks or leaching fields. Not only are septic tanks constructed for a different purpose, but they will tend, because of their construction, to accumulate additional water from the ground during a heavy rain. Overloading them artificially during the rainy season is bad from a slope stability standpoint, and is doubly dangerous since their overflow can pose a serious health hazard. We generally recommend that the use of septic tanks be discontinued as soon as sewers are made available.
10. Don't try to compact earth in trenches by flooding with water. Not only is flooding the least efficient way for compacting fine-grained soil, but this could saturate and reduce the bearing capacity of supporting soils.
11. Don't change the surface grade behind retaining walls because this may increase lateral loading on the walls, which could result in damage to such walls.

In conclusion, a neighbor's slope, above or below a homeowner's property line, is as important to the homeowner as any slope that is inside the property line. For this reason, it is desirable to develop a cooperative attitude regarding hillside maintenance, and we recommend developing a "good neighbor" policy. Should conditions develop off the homeowner's property that are undesirable from indications given above, necessary action should be taken by the homeowner to ensure that remedial measures are taken promptly.

9-5 INNOVATIVE EROSION CONTROL PLANT MATERIALS AND PLANTING PROCEDURES

This discussion of innovations in controlling erosion by using plants and planting procedures tailored to specific sites is provided by Ronald Pecoff, horticulturist and corporate president of Pecoff Brothers Nursery and Seed, Inc., of Escondido, California.

The housing and land development industry has begun to think about practical as well as attractive landscaping. Developers, with their landscape architectural consultants and engineers, are realizing that hillside erosion control landscaping must be tailored for each project. In areas where site requirements dictate the use of supplemental irrigation, then it must be used. If other slopes are to be stabilized permanently, then heavy, excessive, or indiscriminate irrigation must be curtailed. The use of more drought-tolerant, maintenance-free, deep-rooted, and long-lived plant species can accommodate the various adverse soil conditions uncovered during hillside grading and development. The old standby plants utilized in the past do not necessarily work in adverse soil conditions and the newer species of drought- and salt-tolerant plants can be incorporated effectively into many slope planting schemes.

For several years the landscape and erosion control industries have been planting cut and fill slopes with drought-

tolerant surficial ground covers such as ice plants *Carpobrotus edulis* and *Malephora crocea*. (A list of plants and their common names is in Table 9-3.) These slopes have been irrigated sometimes, although infrequently, by a water truck or hose bib manual watering procedure. Frequently they have not been watered at all. The results have been poor erosion control stabilization. Many times these succulent, surficial rooted species have held high concentrations of water in the leaves and stems at the soil surface. When the soil has filled to the saturation point, or to field capacity, the surficial roots have not been able to hold, and much of the surface of the slopes has slipped, particularly during heavy winter rains. The deep-rooted permanent plant species have been found to be the most effective vegetation for permanent soil stabilization.

Some years ago development industries began planting cut and fill slopes grudgingly. Slope plantings were treated as necessary evils—to be planted only as soil protection where required by the government agencies that regulated and approved a particular construction project and/or grading operation. The older cut and fill slopes were planted initially by three different methods. These methods were:

1. hand-planted, non-rooted cuttings of ice plants *Carpobrotus edulis* and *Malephora corcea*, usually set 12 to 24 inches on center;
2. hand-broadcasted or hydroseeded annual grasses such as barley, oats, and rye; and
3. in cases where aesthetically pleasing landscape densities were required quickly, 5-gallon and 15-gallon plants were hand-planted on the slopes.

This third method was always irrigated whereas the first and second methods were nearly always left unirrigated. Remember, cut and fill slopes were treated as necessary evils to be covered and forgotten as soon as possible. This was usually done without consideration of maintenance, irrigation methods, soil structure or chemical analysis, or aesthetic considerations.

The increased cost of building sites and a greater awareness of the marketing appeal that landscaping affords has prompted modern builders to allow the landscape architects to integrate the "hardscape" construction of the site with the landscape, including the slopes. *Hardscape construction* is defined as the solid, inanimate objects used in the landscape, such as walkways, benches, and buildings. The *softscape* is the plant materials within the landscape.

Some high-design builders are integrating the softscape plant materials with the hardscape to provide an indoor/outdoor effect that encompasses the entire site. Slopes are now becoming an integrated part of the landscaping. On many sites the slopes are now treated as garden accent points, and the landscaping there provides for functional slope stabilization as well as background filler.

Exotic specimen plants of 5- and 15-gallon sizes are being set on slopes and in many cases are required by government agencies. Such required specimen plantings provide immediate aesthetic and market benefits for the developers

TABLE 9-3 LIST OF PLANTS
WITH BOTANICAL
AND COMMON NAMES

(suggested by Ronald Pecoff)

<i>Botanical Name</i>	<i>Common Name</i>
Acacia albida	None
Acacia baileyana	Cootamundra wattle
Acacia cavenia	Achillian fleet acacia
Acacia cyclopsis	Coastal wattle
Acacia graffiana	None
Acacia gregii	Cat's claw
Acacia jerrymunjun	Hairy prostrate acacia
Acacia notabilia	None
Acacia 'ONGERUP' (Patent no. 2920)	None
Acacia pycnantha	None
Acacia rostellifera	None
Acacia saligna	Golden wattle
Acacia sophorae	Sydney golden wattle
Achillea millefolium	White yarrow
Atriplex canescens	Four wing salt bush
Atriplex glauca	Creeping salt bush
Atriplex halimus	Sea orach
Atriplex lentiformis	Quail bush
Atriplex nuttleyi	None
Atriplex polycarpa	Saltbrush
Atriplex rhagioiedes	
Atriplex semibaccata	Prostrate salt bush
Atriplex semibaccata var. 'CORTO'	None
Baccharis pilularis prostrata	Prostrate coyote bush
Baccharis pil. consanguinea	Chaparral broome
Baccharis sarothroides	Broome baccharis
Caesalpinia echinata	
Casaurina equisetifolia	South Sea ironwood
Cassia coquimbensis	None
Cercidium floridum	Palo verde
Chilopsis linearifolius	Desert willow
Cistus corsicus	Pink rock rose
Cistus landaniferous	White rock rose
Coreopsis gigantea	Tree coreopsis
Cytissus monosperulensis	French broome
Cytissus scoparius	Scotch broome
Dimorphotheca aurantiaca	S. African trailing daisy
Encelia farinosa	Desert sunflower
Eriogonum fasciculatum	Coastal buckwheat
Eschscholzia californica	California poppy
Eucalyptus polyanthemos	Silver dollar eucalyptus
Eucalyptus seanea	Red gum eucalyptus
Ficus pumila	Creeping fig
Galenia pubescens	None
Geoffra decorticans	None
Grindelia stricta	Gum plant
Isomeris arboreus	Bladder pod
Lathyrus tingitanus	Wild pea
Lotus corniculatus	Birdsfoot trefoil
Lotus scoparius	Deerweed
Lupinus arboreus	Yellow bush lupine
O'Connors legume	Strawberry clover
Pinus canariensis	Canary Island pine
Pinus eldarica	Monterey pine
Pinus halepensis	Aleppo pine
Pinus torreyana	Torrey pine
Plantago indica	Plantain
Populus italica	Italian popular
Prosopis juliflora	Mesquite
Prosopis spicigera	Tamarugo
Prosopis tamarugo	None
Quercus agrifolia	Coastal live oak
Rhus laurina	Laurel sumac
Rhynchelytrum repens	Natal grass
Robinia pseudoacacia	Black locust
Salvia apiana	White sage
Salvia sonomensis	Creeping sage
Shinus molle	California pepper tree
Traepodium majus	Nasturtium
Viguiera lacineata	San Diego daisy
Zauschneria cana	California fuchsis
Ziziphus spina christi	None

and the communities. Where specimen plants have been stipulated, regardless of their adaptability, maintenance requirements, or life expectancy, they have not lasted. Furthermore, some varieties are used indiscriminately without considering their ability to stabilize the slopes. Erosion problems occur here, particularly when excessive water is applied to sustain such specimen plantings.

During the 1969, 1978, and 1980 rainy seasons in Southern California more heavily irrigated, highly sophisticated slope plantings failed or had surficial slippage than did slopes that were unplanted. Such slope failures were the result of accumulated water caused by oversaturation from irrigation compounded by two years of high rainfall, and by the use of specimen plants having excessive top growth and little root development or bottom growth. Our feeling is that many such slope failures could have been prevented by hydroseeding or by planting deep-rooted cover crops and deep-rooted shrubs and trees installed from liners. Specimen plants have three to four times top growth, weight, and height, compared to bottom growth or roots within the containers, thus a ratio imbalance of 3:1 top to root growth. This ratio needs to be reversed where slope erosion control is the primary consideration, so that one part top to three parts root growth in spreading dimensions is provided.

We have come half circle. In the beginning, non-irrigated slope planting procedures using the surficial plant species were generally required. Now highly sophisticated planting projects with fertilizer injection systems, automatic irrigation systems, and continuous maintenance procedures that include spraying for insects and periodic mowing as well as trimming and weed shipping, are required. There are now many projects that have been well planned and are excellent examples of proper landscape planting with the highest priority given to slope stabilization. Slope planting projects need not be stereotyped; they should be suited to the individual site differences that occur on a successional basis. Any blanket edict that requires hand-planted specimens in 15-gallon sizes for all projects is obviously wasteful. Careful consideration and compromise are needed. The first priority is performance, including slope erosion protection, then the aesthetic values of the developer and landscape architect, and the requirements of the community. If a project requires permanent trees and the soil and climatic conditions of the site require that these be irrigated, then irrigation should be employed. If the growing conditions and soil types permit native or adaptable quasi-native non-irrigated species to be grown, then those should be utilized in the erosion control landscape planting or project.

Of course we do not propose either the total rejection of irrigation or of surficial-rooted species. Every plant has a particular function, whether utilitarian or aesthetic. Each species should be considered on its merits or demerits, according to seven major points:

1. The aesthetic effect required; this might vary from manicured to undulating, or that of a flowering meadow or a dense forest.

2. The moisture required, including the plants' drought tolerance balanced with the maintenance costs and procedures, the availability, quantity, and quality of irrigation water.
3. The average life expectancy of the plant species and how it affects the cost of maintenance on a long- or short-term basis.
4. The maintenance work itself: does the particular species require frequent fertilizing, watering, spraying, pesticide application, trimming, and weeding?
5. The root system: is the particular plant palette (the component mix of plants selected for a project) shallow-rooted and densely fibrous? (Such species accumulate high concentrations of water within the first 12 inches of the soil surface.) Does the component mix of plants afford deep-rooted, lateral anchoring roots?—or tap roots that allow ground water to percolate to lower soil strata to extreme depth?
6. The fire danger: are the species highly combustible? Does the plant mix selected for slope stabilization consider the combustibility of the proposed species? Are low fuel combustible species available for a particular site? Is the project site within or adjacent to highly combustible native chaparral plants?

Government agencies frequently require that native or indigenous chaparral species be used to stabilize housing slopes adjacent to native chaparral hillsides to blend and harmonize and maintain continuity with the surrounding land features. Architects and engineers need to know the native plant species that are highly combustible. California natives that are highly combustible are: *Adenostoma fasciculatum* (greasewood), *Artemisia californica* (coastal sage), *Rhus laurina* (laurel sumac), *Salvia mellifera* (black sage), and *Salvia apiana* (white sage). Therefore, other natives or quasi-natives should be selected that are low combustible and contain high concentrations of natural chemical retardants such as sodium, potassium, and boron in their leaves and stems. Examples of such species are: *Atriplex glauca* (creeping salt bush), *Atriplex semibaccata* (prostrate salt bush), *Atriplex semibaccata* var. "CORTO," *Atriplex polycarpa* (various kinds of salt bush), *Cistus corsicus* (pink rock rose), and *Isomeris arboreus* (bladder pod). Many times these low-fuel combustible species are exotics introduced to the chaparral plant community. The decision to use a native-introduced species must be a judgment by the landscape architect and horticultural consultant, based upon their knowledge of the site conditions, soils, available water, water quality, climatic conditions, maintenance considerations, erosion control potential, fire potential, knowledge of the plant's characteristics and growing habits, and the desired landscape effect required by the client.

7. Soil considerations: many newly excavated slopes have high concentrations of chemicals that markedly restrict the growth of certain plant species. If toxic chemicals are found to be present in the soils, the horticultural consultant may be able to select plants

that are resistant to those chemicals, or take special measures to reduce or eliminate the toxic effects by pretreating or removing the affected soil strata before actual landscape installation occurs.

Before an engineer or architect considers any plant palette, establishes any criteria for designing a seedmix, or selects plant materials for slopes, the soil samples, chemical analysis, and physical textures of the various soils at the site need to be considered. Such information as pH (acidity and alkalinity), ECe (total dissolved salts), toxic chemical concentrations of sulfur and boron, for example, as well as percentages of sand, silt, and clay, and the nitrogen, phosphorus, and potassium nutrients available in the soil need to be provided to the landscape architect and the horticultural consultant.

Such information is coordinated by the engineer and landscape architect to be sure that their functional and aesthetic goals are compatible with that of the plant selection and site conditions. Progressive landscape architects and engineers begin analyzing soil samples taken from the boring tests made prior to grading. The analysis for chemical toxicity provides the developer or engineer and the architect with another opportunity to anticipate any soil problems. The developer should schedule a meeting between the horticulturist and the site soil engineer prior to the preliminary soil investigation. For this meeting, the soil engineer should obtain additional soil samples at the proposed plan elevation and grade locations to pass on to the horticulturist for chemical toxicity analysis. Thus the soil and chemical character of the site can be evaluated more completely before earth work is begun, and landscape planning and financing can be better coordinated.

Historically, the engineers and geologists approached slope planting from a functional aspect without consideration for amenities such as textures, flower colors, densities, contrasting leaf colors, flowering season, flow patterns, height variances, and plant succession or life expectancy. Conversely, the landscape architects and nurserymen interpreted slope erosion control planting from a strictly aesthetic aspect without considering the deep or shallow-rooted effects of the plant mix or the problem of oversaturation of the soil by a surficial rooted species that requires irrigation. Where both aspects have not been considered together, some choices of improper plant species have caused surficial erosion, and in extreme conditions slope failures have occurred. Both professional inputs are essential to develop a totally harmonious slope stabilization and landscape program.

For convenient reference a list of plants, arranged by root system types, outlines the rooting characteristics of various species now used effectively by erosion control horticulturists.

SURFICIAL CLUMPING ROOTED SPECIES. This type of root system is characterized by highly concentrated or dense fibrous roots that are usually very fine with little-to-no strength. These roots are situated near the soil surface, forming clumps emanating from the plant in a disk-like appearance when viewed from above. The vertical

depth of roots from such species ranges from 6 to 12 inches, while the lateral spread can be from 12 to 36 inches across. Such species absorb heavy concentrations of surface water, a characteristic which is ideal for surface erosion control, but is the main cause for slope failures when the soil is oversaturated. Examples of surficial clumping rooted species are: *Lobularia maritima* (sweet, or white, alyssum), *Eschscholzia californica* (California poppy), *Cortaderia selloana* (pampas grass), *Dimorphotheca aurantica* (annual African daisy), *Lampranthus spectabilis* (spectacular ice plant), *Malephora crocea* (crocea ice plant), *Festuca rubra* (creeping red fescue), *Gazania hybrid* (South African daisy), common barley, oats, and rye, *Tagetes patula* (marigolds), *Calendula officinalis* (calendula), *Linaria species* (toadflax), *Linum rubra* (annual flax), *Pennisetum setaceum* (fountain grass), *Hippeastrum bicolor* (amaryllis).

SURFICIAL SPREADING ROOTED SPECIES. This type is characterized by a weak, open, sparsely clumping, sometimes rhizomatous rooting system that is often shallow or situated near the soil surface. This type of plant has a predominant rooting pattern extending horizontally from 6 to 12 feet across, usually forming a shallow, spreading pattern. The vertical depth of roots usually ranges from 12 to 24 inches, thus providing little security against mass slope slippage. Species with such root patterns are usually drought tolerant and are suited for soils that are prone to wind erosion primarily rather than water erosion.

Examples of surficial spreading rooted species are: *Atriplex semibaccata* (prostrate Australian salt bush), *Carpobrotus edulis* (common ice plant), *Asparagus sprengeri* (asparagus fern), *Oenothera drummondii* (yellow beach primrose), *Galenia pubescens*, *Ficus pumila*, *Larrea divaricata* (creosote bush), *Rhynchelytrum repens* (natal or ruby grass), *Coreopsis grandiflora* (common showy coreopsis), *Encelia californica* (coastal daisy), *Chrysanthemum leucanthemum* (ox-eye daisy or shasta daisy), *Chrysanthemum segetum* (corn daisy), *Nasturtium hybrid* (common nasturtium), *Osteospermum fruticosum* (trailing South African daisy), *Trifolium repens* (white Dutch clover), and *Dela spermum alba* (white ice plant).

LATERAL ANCHORING ROOTED SPECIES. The lateral anchoring species are characterized by root systems that have both surficial and central tap roots with extensive lateral branching roots. Lateral anchoring roots can be divided into two types:

1. Forking crown roots. These have a thick crown root that forks in the top soil layers to produce several horizontal and vertical spreading lateral roots. In deep soils, the majority of roots are vertical, whereas in shallow soils the roots spread more. Roots may descend to depths of from 6 to 15 feet if the substrata allows: the horizontal expansion ranges from 5 to 20 feet. Examples of forking crown roots are: *Acacia cavenia*, *Acacia cyclopsis*, *Acacia graffiana*, *Acacia gregii*, *Acacia notabilia*, *Acacia saligna*, *Acacia "ONGERUP,"*

Acacia jerrymunjun, *Atriplex canescens*, *Atriplex glauca*, *Atriplex lentiformis*, *Baccharus pilularis consanguinea*, *Cassia coquimbensis*, *Cistus ladaniferous*, *Cytissus scoparius*, *Encelia farinosa*, *Isomeris arboreus*, *Lotus scoparius*, *Lupinus arboreus*, *Eucalyptus seanea*, *Quercus agrifolia*, *Rhus laurina*, *Salvia apiana*, *Viguiera lacineata*, *Grindelia stricta*, *Pinus Torreyana*, and *Shinus molle*. (Common names are given in Table 9-3.)

2. Rhizomatous horizontal branching roots. Rhizomatous plants produce horizontal stems on or below the ground that send up a succession of leaves or stems at the apex. At first the root stock grows downward, then branches off to form extensive horizontal lateral roots. The laterals produce vertical offshoots (rhizomatous succoring), which descend farther before branching horizontally again. This root growth pattern may be repeated many times to produce a subterranean root system of enormous dimensions. Scores of aerial shoots may also develop, resulting in the generation of enormous aerial offsprings from a single root stalk. This is the most effective type of rooting system for erosion control protection. The rooting depth ranges from 3 to 60 feet; horizontal expansion ranges from 3 to 60 feet also. Obviously, the enormous variances are dependent upon the species selected. Examples of lateral anchoring rhizomatous rooting species are: *Acacia rostellifera*, *Acacia albida*, *Caesalpinia echinata*, *Geoffra decorticans*, *Prosopis spicigera*, *Robinia pseudoacacia*, *Ziziphus spina christi*, *Populus italica*, *Achillea millefolium*, *O'Connors leguma*, *Zauschneria cana*, *Salvia sonomensis*, *Baccharus pilularis prostrata*, *Atriplex nuttlei*, and *Atriplex rhagioiedes*. (Common names are given in Table 9-3.)

CENTRAL TAP ROOTING SPECIES. The rooting systems of these species are strongly vertical with each plant penetrating to depths greater than 24 feet in uninhibited soils. Such deep-rooted species may survive extreme drought conditions and also be able to penetrate the cracks and crevices of rocky cut slopes. The enormous tap root system allows these plants to anchor firmly in the soil while dissipating surface water to lower soil strata via the vertical tap roots. Thus, tap rooting plants act as excellent soil stabilizer and water dispersant systems. There is poor lateral spread and branching in the central tap system, which provides a horizontal spread ranging from 6 to 12 feet. The main benefits of the central tap rooting system are anchoring, drought tolerance, and water dispersment.

A few examples of central tap rooting species are: *Acacia baileyana*, *Acacia pycnantha*, *Atriplex halimus*, *Baccharus sarothroides*, *Cercidium floridum*, *Casaurina equisetifolia*, *Pinus canariensis*, *Pinus eldarica*, *Pinus halepensis*, *Chilopsis linearifolius*, *Prosopis juliflora*, and *Prosopis tamaruga*.

The following erosion control projects have succeeded as a result of total cooperation among the landscape architect, horticultural consultant, geologist, soil engineer, municipality, and developer.

**PROJECT I: MISSION VALLEY CROSSROAD SLOPES,
SAN DIEGO, CALIFORNIA**

1. *Requirement*—to revegetate a 380-foot vertical cut mountain that was completely denuded. The landscape architectural firm envisioned the planting materials to provide a permanent, deep-rooted forestation effect with a two-layer canopy requiring Eucalyptus trees that would grow 80 feet high and blend with the surrounding ridge trees and an understory canopy of large Acacias growing to 20 feet in height. Furthermore, the planting was to be installed by hydroseeding then hand planting one-gallon trees 50 feet on center. The hydroseeding mixture was required to contain fast-growing surficial erosion control nurse crops coupled with procumbent mounding sub-shrubs and ground covers to provide total erosion control stabilization, aesthetic beauty, and the required landscape density.
2. *Climate*—a cismontaine coastal climate having a typical Mediterranean microclimate with summer fog, little-to-no frost, three months of winter rains, nine months of drought, and dry desert, or *Santana*, winds during the autumn. (A *cismontaine coastal climate* is defined as that of the western slopes of the Sierra Nevada Mountain Range confined primarily to the chaparral foothills. *Santana* winds are defined as high easterly winds coming off the California deserts with extreme gusts.)
3. *Soils*—a cut mountain emanating from a marine terrace formation containing conglomerated sandstone pebbles, sandstone, limestone, and mudstone rock. There were six soil types having pH's ranging from 4.5 to 8 with pockets of boron and sodium chlorides. ECe (total dissolved) salts ranged from .6 to 9.
4. *Slopes*—from 2:1 to $\frac{1}{2}$:1. The cut slope was a 380-foot-high vertical cut.
5. *Area*—approximately 10 acres of slopes.
6. *Irrigation*—A permanent automatic irrigation system, using both impact and minipact sprinkler heads, was installed above ground. A fertilizer injection system was attached to the irrigation system, thus fertilizing the slopes with low concentrations of nutrients every time the water was turned on. The fertilizer injection system was employed for the first 24-months following installation.
7. *Maintenance*—The irrigation system was monitored weekly by maintenance personnel, although the automatic irrigation sequence was initially set to provide supplemental watering three times a day for five minutes per watering period. The maintenance personnel were to ensure that the sprinkler heads and time clocks were operating correctly. Thus, moisture was provided to the hydroseeding slopes until the plants were well established. After a 24-month period, automatic irrigation was discontinued, and water was applied on a need-be basis for an additional 12 months. Irrigation and maintenance were totally discontinued then since the plants were adapted to the climatic conditions and the site without further irrigation.
8. *Seedmix*—The erosion control hydroseeding seedmix consisted of Mission Valley No. 69, which contains *Cytissus monopensulensis*, *Eucalyptus seanea*, *Eucalyptus polyanthemos*, *Lathyrus tingitanus*, *Acacia saligna*, *Acacia sophorae*, *Atriplex semibaccata*, *Cistus corsicus*, *Coreopsis gigantea*, *Eriogonum fasciculatum*, *Lotus corniculatus*, and *Lupinus arboreus*.

Figure 9-27 shows the Mission Valley Crossroad Slopes hydroseeding seedmix Mission Valley No. 69 four weeks

Figure 9-27 Mission Valley Crossroad Slopes four weeks after the installation of hydroseeding seedmix Mission Valley No. 69. Photograph by and courtesy of Ronald Pecoff.

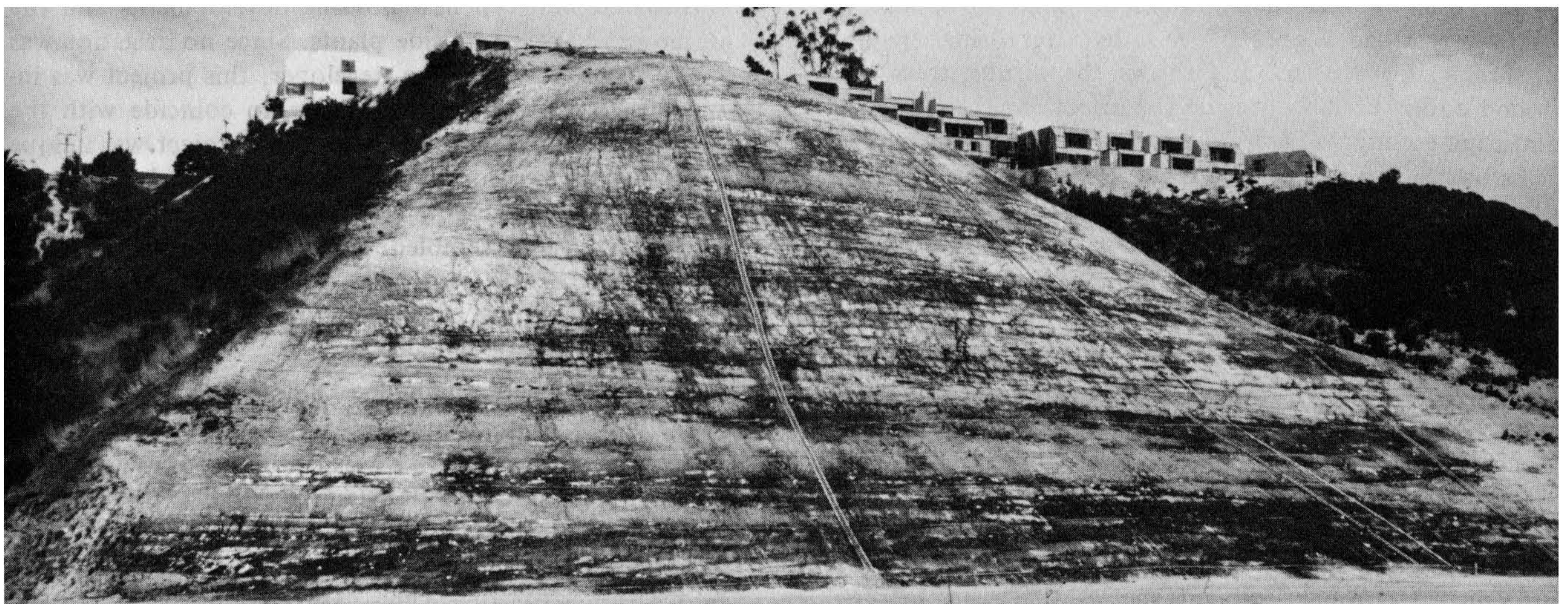



Figure 9-28 Mission Valley Crossroad Slopes fifteen months after using seedmix Mission Valley No. 69. Shrubs, trees, and ground covers provide the effect envisioned by the landscape architect. Photograph by and courtesy of Ronald Pecoff.

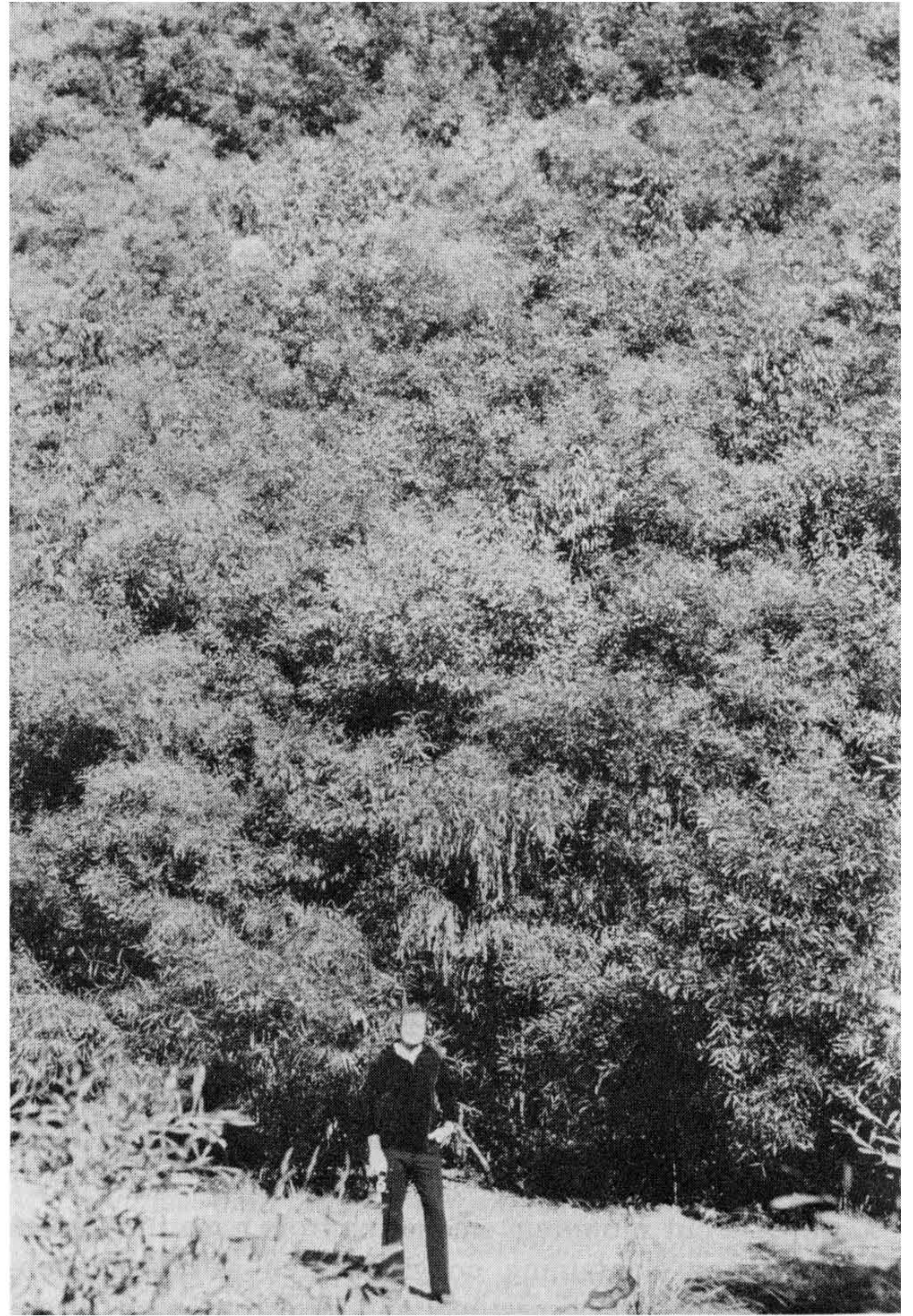

Figure 9-29 Mission Valley Crossroad Slopes seedmix Mission Valley No. 69 four years after hydroseeding installation. No further maintenance has been provided since the growth was established. Photograph by and courtesy of Ronald Pecoff.

after hydroseeding installation. Figure 9-28 shows Mission Valley Crossroad Slopes 15 months after using seedmix Mission Valley No. 69 and shows the shrubs, trees, and ground covers used to provide the effect envisioned by the landscape architect. Figure 9-29 depicts the Mission Valley Crossroad Slopes seedmix, Mission Valley No. 69 four years after hydroseeding installation. No further maintenance was provided.

PROJECT II: LA COSTA DEVELOPMENT CORPORATION, VALE IV

1. *Requirements*—to re-vegetate an overburdened basaltic rocky fill with deep-rooted native ground covers, low procumbent shrubs, and tall deep-rooted trees as well as attractive flowering annual nurse crops that would reseed themselves each year. The highest priority was to use plant species that required no irrigation (natural rainfall). Drought-tolerant species that were low-fuel combustible were also required because the slopes were

situated between new housing developments and the native chaparral hillside plants. Since no irrigation was to be provided by the developer, this project was installed during the early winter to coincide with the beginning of the rainy season. The project was unique in that the method of installation was aerial seeding via helicopter. (See Figure 9-30.) The seedmixture, or plant pallette, was assembled from various drought areas including South Australia, Death Valley, the Karoo District of South Africa, and the Southern California chaparral plant community.

2. *Climate*—a cismontaine coastal climate having a typical Mediterranean microclimate with summer fog, little-to-no frost, three months of winter rains, nine months of drought, and dry desert, or Santana, winds during the autumn.
3. *Soils*—an overburden rocky basaltic boulder and gravel mixture with some clays. This mixture was approximately 3 feet deep and was placed as an overburdened

fill over a solid mountain cut of basaltic rock. The pH ranged from 6.5 to 7.5 with no salts. The overburden material was sterile of plant nutrients. Thus, low-nutrient-requiring species were selected.

4. *Slopes*—2:1, averaging 50 to 75 feet in height.



Figure 9-30 Aerial helicopter seeding of Vale IV, No. 117 seedmix for the La Costa Development Corporation. Photograph by and courtesy of Ronald Pecoff.

5. *Area*—Approximately 8 acres of slopes.

6. *Irrigation*—The seedmix plant pallette was selected for non-irrigated conditions and was totally dependent upon natural rainfall for germination and to sustain permanent plant growth.

7. *Maintenance*—The project was not to be maintained. The seedmix pallette was designed to adapt as a native although some components were exotics. These exotic species were selected because of their adaptability and maintenance-free characteristics.

8. *Seedmix*—This hydroseeding seedmix, Vale IV, No. 117, consisted of *Plantago indica*, *Atriplex glauca*, *Eucalyptus seanea*, *Eschscholzia californica*, *Dimorphotheca aurantiaca*, *Encelia farinosa*, *Eriogonum fasciculatum*, and *Acacia baileyana*.

Figure 9-31 shows the results of seeding Vale IV, No. 117 120 days after the helicopter installation. The mass flowering cover is primarily *Dimorphotheca aurantiaca* that had grown after three rainfalls with no supplemental irrigation.

Figure 9-32 shows the results of seeding Vale IV, No. 117 seven months after the initial helicopter installation. The species noted in the photograph are *Encelia farinosa*, *Atriplex glauca*, and *Eriogonum fasciculatum*. All are procumbent mounding spreading perennial ground covers with grey-green foliage. The flowering species are predominantly *Eschscholzia californica* and *Dimorphotheca aruantiaca*. The additional summer flowering period was the result of a two-inch summer rain. The *Acacia baileyana* and *Eucalyptus seanea* seedlings are not visible in the photograph; however, they were approximately three to four inches in height and evenly distributed over the slope.



Figure 9-31 The results of seeding Vale IV, No. 117 one hundred and twenty days after helicopter installation. The mass flowering cover is primarily *Dimorphotheca aurantiaca* (South African trailing daisy) that has grown without supplemental irrigation but after three rainfalls. Photograph by and courtesy of Ronald Pecoff.



Figure 9-32 The results of seeding Vale IV, No. 117 seven months after the helicopter installation. Photograph by and courtesy of Ronald Pecoff.

**PROJECT III: EL KHAN FREEWAY BRIDGE,
STATE OF SHARJAH, UNITED ARAB EMIRATES**

1. *Requirements*—vegetate and provide erosion-control protection from both wind and rain on freeway embankment slopes in the State of Sharjah, United Arab Emirates. The project site is halfway around the world and is extremely adverse in soil, climate, and working conditions. The owner and ruler of this country required that the slopes be planted with colorful ground covers and low-mounding shrubs as well as grasses that are drought- and salt-tolerant as well as long-lived and relatively maintenance-free.
2. *Climate*—an arid, or rain desert, climate within the extra tropical zone with winter precipitation. Temperatures range from a low of 55°F to a high of 130°F. The humidity ranges from 11% to 90%. The area is subject to extremely hot desert winds that reach 80 mph at times. The annual rainfall occurs within a three-to-five-day period, usually with an intensity that causes flash flooding and severe erosion within a short period of time. The climatic conditions are extremely severe—drought may last over 11 months per year—so the plant palette must be able to adapt to these conditions.
3. *Soils*—dredged ocean soils containing sands, gravel, sea-shells, and some clays. The soils contained high concentrations of sodium chloride having an ECe reading of 26.56; therefore, they had to be leached for several days to reduce the salt concentration to an ECe of 6.25. Since these soils were highly erodable, and the sands were subject to wind and surface water erosion due to intensive winter flash flooding, special plants were required that could tolerate these conditions.
4. *Slopes*—from 3:1 to 4:1 within a non-compacted dredged sand.
5. *Area*—Approximately 15 acres of slopes.
6. *Irrigation*—An automatic irrigation system was installed utilizing an above-ground black PVC mono wall porous drip irrigation tubing. This tubing operates on 10 psi. The drip tubing was especially designed to tolerate high temperatures and high concentrations of salt in the irrigation water. It was essential that the irrigation system be controlled automatically to minimize maintenance labor.
7. *Maintenance*—The automatic irrigation system was set to irrigate for 15-minute intervals, five times a day, to guarantee germination. Once the hydroseeding mixture germinated and was sufficiently established, the irrigation sequence was modified to irrigate twice a



Figure 9-33 Hydroseeding installation at the El Khan Bridge Freeway Project, State of Sharjah, United Arab Emirates, November, 1978. This seedmixture was drilled into dredged sand via hydroseeding. Photograph by and courtesy of Ronald Pecoff.

day for 1-hour periods. After one year of growth, plants were sufficiently established to change the irrigation sequence again to allow the system to water once a week for a 1-hour period. Supplemental fertilizer with a balanced NPK commercial formula was applied every three months for the first year, after which time one fertilizer application per year would be required.

8. *Seedmix*—This hydroseeding seedmix, UAE No. 198, consisted of *Plantago indica*, *Dimorphotheca aurantiaca*, *Gazania hybrid*, *Atriplex semibaccata*, *Rhynchelytrum repens*, and *Encelia farinosa*.

Figure 9-33 shows the hydroseeding installation at the El Khan Bridge Freeway Project during November 1978. The seedmixture was drilled into the dredged sand via hydroseeding.

Figure 9-34 shows three month's growth of the UAE No. 198 seedmix at the El Khan Bridge Project. The predominant growth occurred along the drip irrigation tubing. The primary species depicted was a temporary erosion control annual, *Plantago indica*.

Figure 9-35 shows six month's growth of seedmix UAE No. 198 at the El Khan Bridge Project. The seedmixture was in full flower and the perennial ground covers were suf-



Figure 9-34 Three months' growth of UAE No. 198 seedmix at the El Khan Bridge Project. Predominate growth is occurring along the drip irrigation tubing. Photograph by and courtesy of Ronald Pecoff.



Figure 9-35 Six months' growth of seedmix UAE 198 at the El Khan Bridge Project. The seedmixture is in full flower, and the perennial ground covers are sufficiently established to begin growing horizontally, thus providing 100% erosion control coverage and maximum density. Photograph by and courtesy of Ronald Pecoff.

Figure 9-36 Seedmix UAE 198 eight months after installation. Now it provides an esthetically pleasing dense flowering cover which softens the hardscape of the bridge and freeway construction. Photograph by and courtesy of Ronald Pecoff.





Figure 9-37 The results of seedmix UAE 198 at the Sharjah, UAE, El Khan Bridge Project after thirteen months' growth. The annual flowers have disappeared, and perennial shrubs and flowering grasses dominate the slopes. Photograph by and courtesy of Ronald Pecoff.

ficiently established to begin growing horizontally, thus providing 100% erosion control coverage and mass density.

Figure 9-36 shows seedmix UAE No. 198 eight months old, providing an aesthetically pleasing flowering dense cover that softens the hardscape of the bridge and freeway construction.

Figure 9-37 shows the results of seedmix UAE No. 198 at the Sharjah, UAE, El Khan Bridge Project after 13 months' growth. The annual flowers have disappeared, and the perennial shrubs and flowering grasses dominate the slopes.

PROJECT IV: ROLLING HILLS ESTATE, ANAHEIM HILLS CORPORATION—ANAHEIM, CALIFORNIA

1. *Requirements*—to re-vegetate graded and contoured housing slopes prior to construction by providing a manicured landscape effect. The erosion control plant palette utilized low-growing, deep-rooted, permanent ground covers that contained a combination of perennial flowers and surficial annual cover crops. The highest priority was given to special plants that required little-to-no maintenance once established. Due to the erodability of the soil, there was a special need for ground covers that would succor rhizomatously underground as well as re-root horizontally along the

soil surface. Therefore, the seedmix contained special provisions to include such species.

2. *Climate*—a cismontaine coastal valley climate with a typical Mediterranean condition of winter rains, morning summer fog, some winter frost, nine months of drought, and extremely dry desert, or Santana, winds reaching 60 mph in the early autumn.
3. *Soils*—a sandy silt with clay and some mudstone material. The pH ranged from 6.5 to 8 with no salt problems. This soil was subject to surface erosion and deep-seated slippage problems when supersaturated; thus, deep-rooted species having lateral anchoring roots as well as rhizomatous horizontal branching root systems were required.
4. *Slopes*—from 2:1 to 3:1 and graded to form a rolling, sculptured contoured appearance.
5. *Area*—Approximately 46 acres.
6. *Irrigation*—An automatic irrigation system of Anjac bi-wall drip irrigation tubing spaced 3- to 4-feet on center and laid horizontally on the soil surface paralleling the slope contour was used here.
7. *Maintenance*—Maintenance was limited to monitoring the irrigation timing sequence to ensure deep watering and to periodic inspection of the drip tubing by maintenance personnel to ensure that ground squirrels and gophers had not damaged the tubing. Supplemental

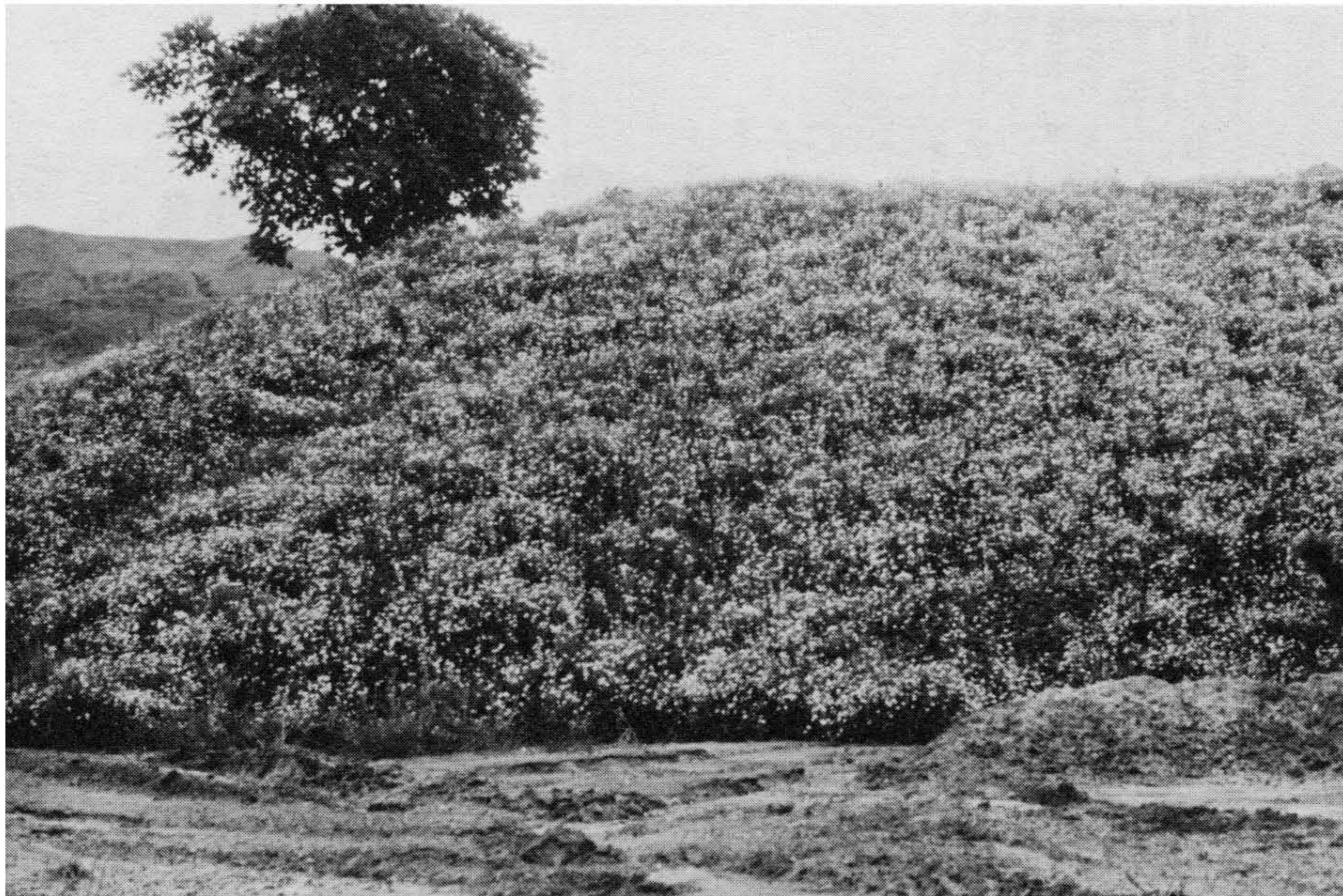

Figure 9-38 Rolling Hills Estates, Anaheim, CA. seedmix Rolling Hills Berm No. 43 after three months, showing dense growth of a surficial cover crop of *Lasthenia glabrata*. Photograph by and courtesy of Ronald Pecoff.

fertilizing every six months was necessary for the first 3 years or until the plants were adapted to the soil conditions.

8. *Seedmix*—The hydroseeding seedmix Rolling Hills Berm No. 43 consisted of *O'Connors legume*, *Dimorphotheca aurantiaca*, *Nasturtium hybrid*, *Gazania hybrid*, *Lasthenia glabrata*, *Encelia farinosa*, and *Alyssum Carpet of Snow*.

Figure 9-38 shows the dense growth of the surficial cover crop of *Lasthenia glabrata*, 3-months old, at the Anaheim Hills, Rolling Hill Estates, utilizing seedmix Rolling Hills Berm No. 43.

Figure 9-39 shows five months of growth of seedmix Rolling Hills Berm No. 43. Here the figure shows heavy concentrations of *O'Connors legume*, which provides 100% coverage and erosion control protection. Some *Lasthenia glabrata* and *Nasturtium hybrid* appear in flower.

Figure 9-40 shows the results after 12 months of growth on the contoured housing slopes utilizing the seedmix Rolling Hills Berm No. 43. Here the plant pallette has developed fully; the *O'Connors legume* has formed a manicured dense cover, and gazanias, poppies, and nasturtiums have matured and begun to flower.

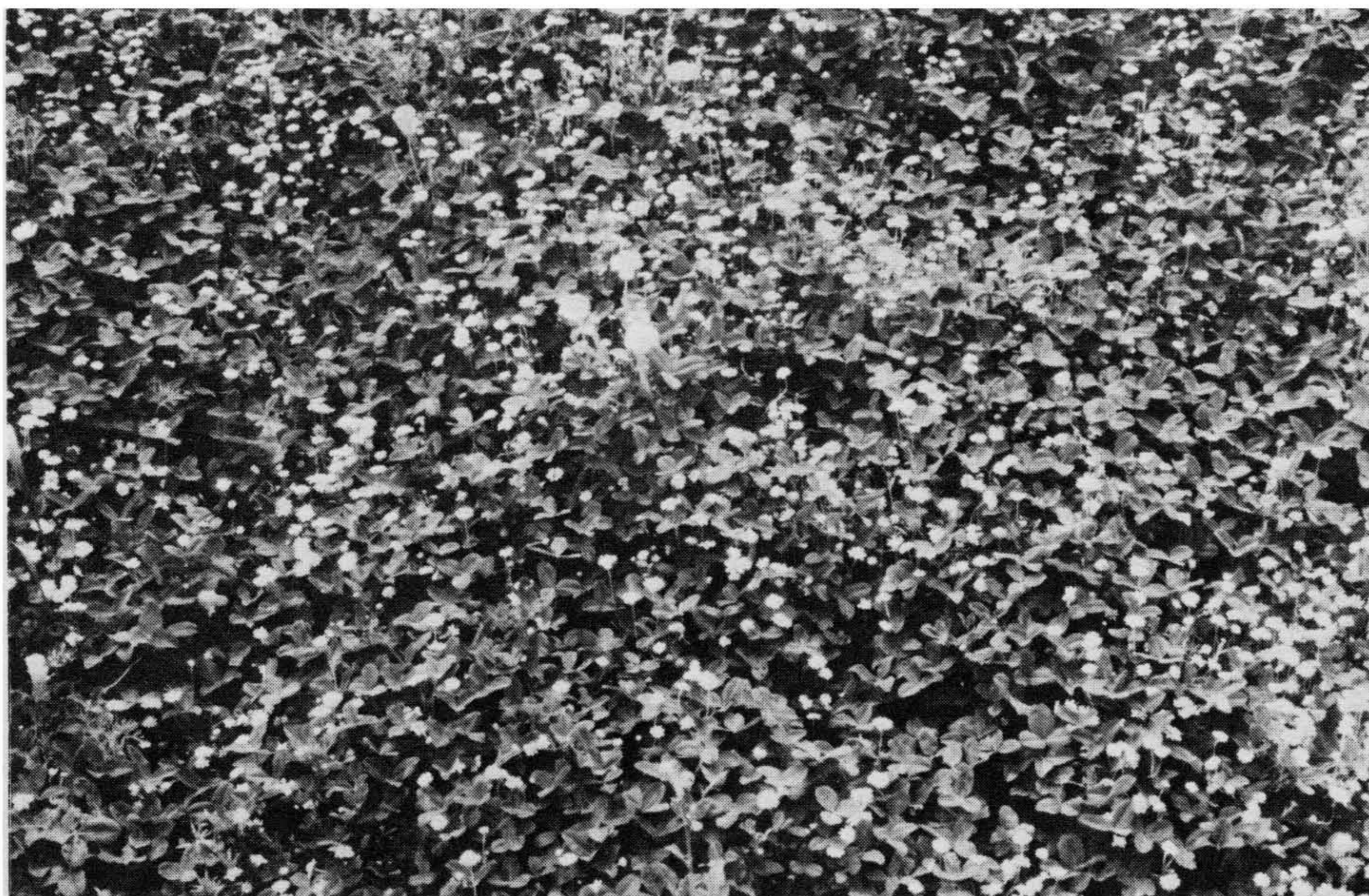

Figure 9-39 The Rolling Hills Berm No. 43 seedmix after five months of growth. Heavy concentrations of *O'Connors legume* (strawberry clover) provide 100% coverage and erosion control protection with some *Lasthenia glabrata* and *Nasturtium hybrid* in flower. Photograph by and courtesy of Ronald Pecoff.



Figure 9-40 The results of twelve months' growth on contoured housing slopes utilizing Rolling Hills Berm No. 43 seedmix. The plant pallette hydroseeding mix has developed fully where the *O'Connors legume* has formed a

manicured dense cover and the gazanias, poppies, and nasturtiums have begun to mature and flower. Photograph by and courtesy of Ronald Pecoff.

9-6 SUMMARY AND CONCLUSIONS

Drainage control is the basic consideration in the stability and long-term performance of hillside residential lots. The primary considerations of soil erosion and land and structural stability and settlement are related directly to the control of drainage.

Landowners need to be aware of the requirements and methods for creating and maintaining safe building sites. Residents need information that tells them how they can best maintain their sites so that inclement weather does not destroy the stability of their habitations.

Planting slopes with water- and fire-resistant plants, strict control of the irrigation water application on hillside slopes, periodic cleaning and maintenance of slope and yard drains, and the development of awareness and good judgment relative to drainage control are requisites for longevity and safety of hillside homesites.

In Chapter 9 we discussed several positive methods of drainage control and maintenance of homesites. Chapter 10 discusses buttress design, and is oriented primarily for the plan-check or design engineer. It includes a highly specialized method of stabilizing or supporting hillside slopes by the buttress method. It is assumed that most plan-check engineers are civil engineering specialists—either graduates or students—and should be able to follow the technical discussion of buttress design.

References

1. Glenn A. Brown, LeRoy Crandall and Associates, "Phase I Investigation of Ground Water Conditions, Village of Turtle Rock, City of Irvine, California, for the City of Irvine Task Group," Orange County, California, Job #E-78386, March 1979, pp. 33-39 (Xeroxed).
2. State of California Water Rights Board Staff, "Provisional Report, San Fernando Valley Reference" (Sacramento: The State of California, Dec. 1960), Volumes I-III.
3. C. D. Gustafson, "Basic Irrigation Principles," *California Geology* (Nov. 1978), pp. 263-267.
4. GeoSoils, Inc., "Maintenance of Hillside Homesites for Slope Stability and Erosion Control" (Van Nuys, California), approximately 6 pages (Xeroxed).

EXCAVATION AND GRADING CODE ADMINISTRATION, INSPECTION, AND ENFORCEMENT

C. Michael Scullin

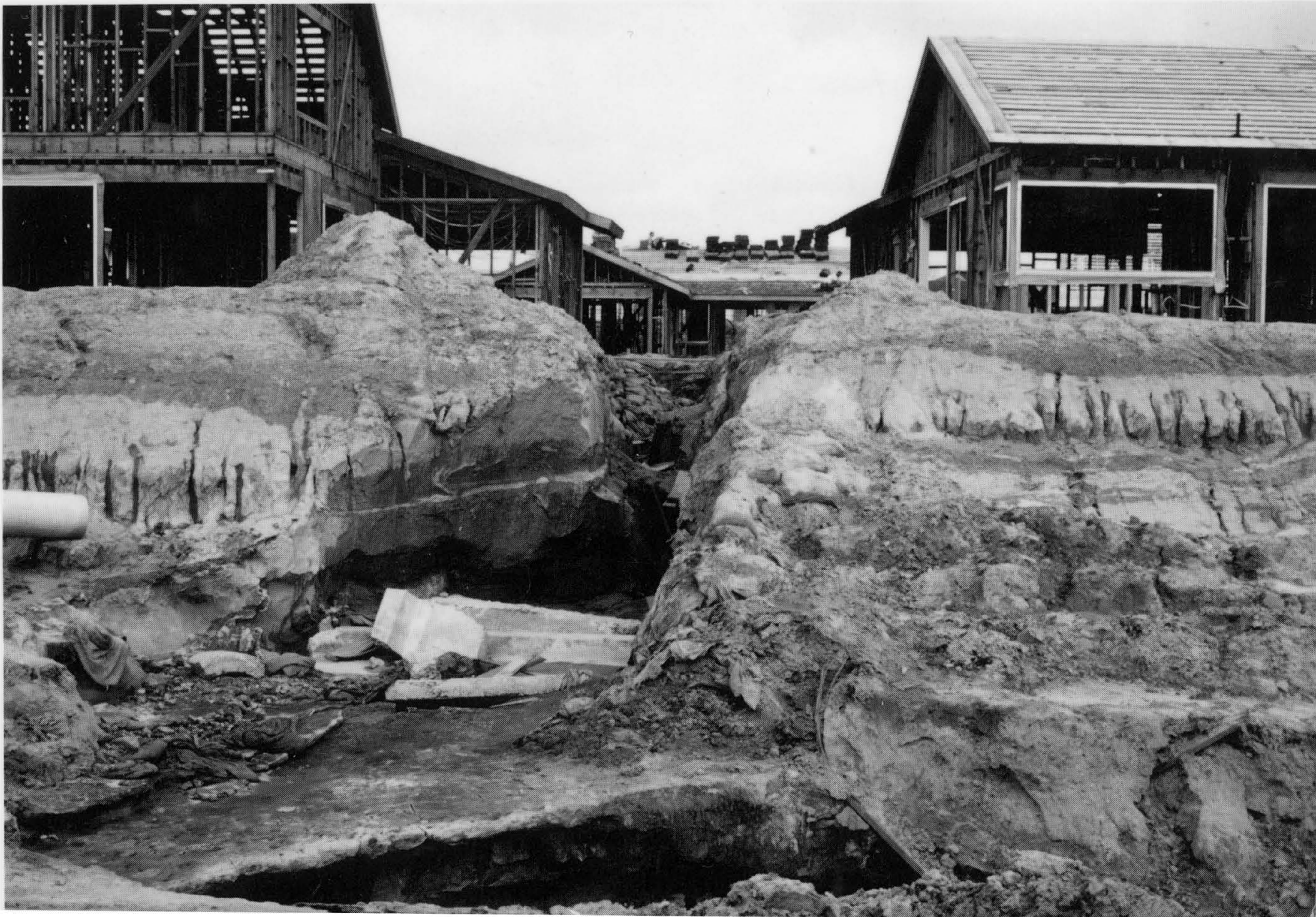

EXCAVATION AND GRADING CODE ADMINISTRATION, INSPECTION, AND ENFORCEMENT

C. MICHAEL SCULLIN

*Former Grading Section Supervisor
County of Orange, California*

*Consulting Engineering Geologist
Thousand Oaks, California*

With a foreword by

JAMES E. SLOSSON, Ph.D.

President, State of California Board of Registration
for Geologists and Geophysicists, and
Professor of Earth Sciences,
Los Angeles Valley College