

# Molecular Models & Lewis Dot Structures

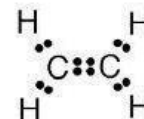

## Objectives:

1. Draw Lewis structures for atoms, ions and simple molecules.
2. Use Lewis structures as a guide to construct three-dimensional models of small molecules.
3. Determine the electron and molecular geometry of the produced molecules.

## Background:

Scientists often create models to represent either a physical or abstract system or structure that cannot be observed directly. One of the earliest models of the atom was developed by the atomists who were followers of the Greek philosopher Leucippus, the most famous of whom was Democritus. According to their theory, atoms were solid indivisible masses traveling through a void. When J.J. Thomson discovered that atoms can be divided, he concluded that atoms are made of positive cores with negatively charged particles in them. In 1904, he created his Plum Pudding Model where the atom was seen as a positive pudding that had negative plums in it. (*Americans might more readily relate plum pudding to a blueberry muffin, where the muffin would be positive and the blueberries would be negative.*) This model was later discarded in 1911 when Ernst Rutherford's graduate students performed their gold foil experiment and concluded that atoms must have a small dense positive center surrounded by a cloud of electrons. In 1913, Niels Bohr developed a solar system model of the atom based on his work on atomic structure where the electrons travel in discrete orbitals around the nucleus. With only some minor adjustments, this is the model that is still used today.

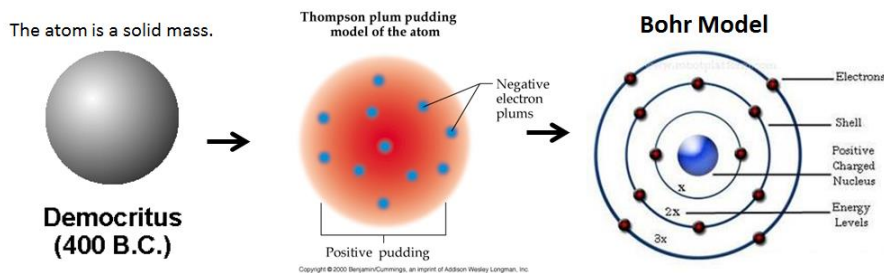

With the innovation of discrete shells, scientists needed a way to describe the placement of electrons in an atom or ion. Two distinct methods were developed simultaneously. The quantum method was preferred by physicists. It involves placing electrons into orbital diagrams. This provides an arrangement of electrons in a way that is easy to visualize. In an orbital filling diagram, the individual orbitals are shown as circles (or boxes), and orbitals within the same sublevel are drawn next to each other horizontally. Sublevels can be shown where energy increases as the boxes move up the page. Sublevels can also be shown horizontally one after the other. Each sublevel is labeled by its principal energy level and sublevel. Electrons are indicated by arrows inside the boxes. An upward pointing arrow indicates one spin direction, while an arrow pointing downward indicates the other direction. The boxes can contain at most only one up arrow and one down arrow. The orbital filling diagrams for hydrogen and helium are shown below.

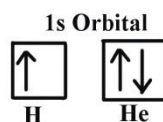

The way in which the electrons are distributed among the various orbitals of an atom is called its electron configuration. The most stable electron configuration (or the ground configuration) of an atom is the one in which the electrons are in the lowest possible energy states. All the electrons then would crowd into the 1s orbital because it has the lowest in energy if it were not for the restrictions on the number of electrons in an orbital. The Pauli Exclusion Principle states that there can be at most two electrons in any single orbital. The orbitals are filled in order of increasing energy with no more than two electrons per orbital. An energy level diagram is shown below.

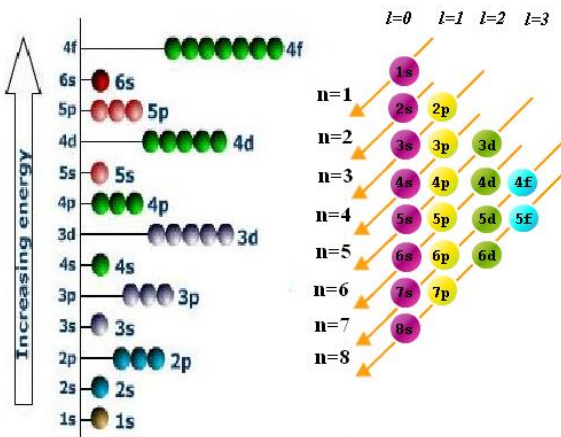

Since helium has two electrons in the 1s orbital then it is considered a closed orbital. The next atom lithium has three electrons. This third electron must go into the next lowest energy orbital, the 2s. The electron configuration can also be summarized by writing the symbol for the occupied subshell and adding a superscript to indicate the number of electrons in that subshell. For example, lithium would be written as  $1s^2 2s^1$  (and read as "1s two, 2s one"). An electron configuration table for lithium to sodium is provided below.

Element	Total Electrons	Orbital Diagram				Electron Configuration
		1s	2s	2p	3s	
Li	3	$\uparrow\downarrow$	$\uparrow$	$\square \square \square$	$\square$	$1s^2 2s^1$
Be	4	$\uparrow\downarrow$	$\uparrow\downarrow$	$\square \square \square$	$\square$	$1s^2 2s^2$
B	5	$\uparrow\downarrow$	$\uparrow\downarrow$	$\uparrow \square \square$	$\square$	$1s^2 2s^2 2p^1$
C	6	$\uparrow\downarrow$	$\uparrow\downarrow$	$\uparrow \uparrow \square$	$\square$	$1s^2 2s^2 2p^2$
N	7	$\uparrow\downarrow$	$\uparrow\downarrow$	$\uparrow \uparrow \uparrow$	$\square$	$1s^2 2s^2 2p^3$
Ne	10	$\uparrow\downarrow$	$\uparrow\downarrow$	$\uparrow\downarrow \uparrow\downarrow \uparrow\downarrow$	$\square$	$1s^2 2s^2 2p^6$
Na	11	$\uparrow\downarrow$	$\uparrow\downarrow$	$\uparrow\downarrow \uparrow\downarrow \uparrow\downarrow$	$\uparrow$	$1s^2 2s^2 2p^6 3s^1$

With beryllium, the 2s orbital is filled. So for boron, the next electron must be placed in the 2p orbital. For carbon, the sixth electron must also go into a 2p orbital; however, it does not go into the same orbital as the fifth electron. According to Hund's rule, the lowest energy is attained when the number of electrons with the same spin is maximized for degenerate orbitals (degenerate = alternate orbitals at the same level). That is, electrons will individually occupy orbitals as much as possible with their spins

parallel. Hund's rule is based partially on the fact that electrons repel one another. By occupying different orbitals, the electrons remain as far apart as possible from one another. This minimizes electron-electron repulsions. So for a carbon atom to achieve its lowest energy, the two 2p electrons will need to have the same spin which means they must occupy different 2p orbitals. In the ground state then carbon has two unpaired electrons. Likewise, nitrogen would have three 2p electrons: one in each of the three 2p orbitals. This way all three electrons can have the same spin. For oxygen, fluorine and neon, the fourth, fifth and sixth electrons, respectively, are added to the half-filled orbitals. The 2p subshell is now full.

The next electron for sodium goes into the 3s orbital. The electron configuration for sodium can be shown as  $1s^2 2s^2 2p^6 3s^1$ . There is also a shorthand notation based on the noble gas configuration where only the electrons in excess of the noble gas immediately preceding the atom in the periodic table. The noble gas is shown in brackets [ ] and followed by the standard notation for the excess electrons. So sodium has one 3s electron in excess of the noble gas neon. The shorthand notation for Na is  $[\text{Ne}]3s^1$ . The shorthand method helps focus attention on the outermost or valence electrons of the atom.

The periodic table provided below shows only the outer electron number and the electron orbital that it occupies.

1A		2A												3A	4A	5A	6A	7A	0
1s <sup>1</sup>	1s <sup>2</sup>																		
2s <sup>1</sup>	2s <sup>2</sup>											2p <sup>1</sup>	2p <sup>2</sup>	2p <sup>3</sup>	2p <sup>4</sup>	2p <sup>5</sup>	2p <sup>6</sup>		
3s <sup>1</sup>	3s <sup>2</sup>	3B	4B	5B	6B	7B	8B			1B	2B	3p <sup>1</sup>	3p <sup>2</sup>	3p <sup>3</sup>	3p <sup>4</sup>	3p <sup>5</sup>	3p <sup>6</sup>		
4s <sup>1</sup>	4s <sup>2</sup>	3d <sup>1</sup>	3d <sup>2</sup>	3d <sup>3</sup>	3d <sup>4</sup>	3d <sup>5</sup>	3d <sup>6</sup>	3d <sup>7</sup>	3d <sup>8</sup>	3d <sup>9</sup>	3d <sup>10</sup>	4p <sup>1</sup>	4p <sup>2</sup>	4p <sup>3</sup>	4p <sup>4</sup>	4p <sup>5</sup>	4p <sup>6</sup>		
5s <sup>1</sup>	5s <sup>2</sup>	4d <sup>1</sup>	4d <sup>2</sup>	4d <sup>3</sup>	4d <sup>4</sup>	4d <sup>5</sup>	4d <sup>6</sup>	4d <sup>7</sup>	4d <sup>8</sup>	4d <sup>9</sup>	4d <sup>10</sup>	5p <sup>1</sup>	5p <sup>2</sup>	5p <sup>3</sup>	5p <sup>4</sup>	5p <sup>5</sup>	5p <sup>6</sup>		
6s <sup>1</sup>	6s <sup>2</sup>	5d <sup>1</sup>	5d <sup>2</sup>	5d <sup>3</sup>	5d <sup>4</sup>	5d <sup>5</sup>	5d <sup>6</sup>	5d <sup>7</sup>	5d <sup>8</sup>	5d <sup>9</sup>	5d <sup>10</sup>	6p <sup>1</sup>	6p <sup>2</sup>	6p <sup>3</sup>	6p <sup>4</sup>	6p <sup>5</sup>	6p <sup>6</sup>		
7s <sup>1</sup>	7s <sup>2</sup>	6d <sup>1</sup>	6d <sup>2</sup>	6d <sup>3</sup>	6d <sup>4</sup>	6d <sup>5</sup>	6d <sup>6</sup>	6d <sup>7</sup>											
												transuranium elements							
												Lanthanides	4f <sup>1</sup>						4f <sup>14</sup>
												Actinides	4f <sup>1</sup>						4f <sup>14</sup>

*I've written He over here because it makes better sense for now.*

So while the physicists were focusing on the quantum method of annotated electrons, the chemists were more concerned about how the electrons affected chemical reactions. In 1916, Gilbert N. Lewis, an American physical chemist determined that elements tend to interact to achieve an electronic structure similar to the noble gases. In this way, the elements can become more stable. Because the noble gases (with the exception of helium) have eight electrons in their outer shell, this is often referred to as the "Octet Rule."

Most bonds cannot be represented by a complete transfer of electrons from one atom to another. This type of transfer only occurs in the ionic bonding of metals with non-metals. Covalent bonds are formed when two non-metals share their valence electrons. (*Valence electrons are the ones located in the outermost shell of an atom. For the principal group elements, only the valence electrons are involved in chemical reactions.*) By sharing their electrons, the two non-metal atoms are able to achieve filled valence orbitals. Most non-metals then will try and acquire enough shared electrons so that they have eight valence electrons like their nearest noble gas neighbor. (An exception would be hydrogen, H, which only needs to acquire two electrons to be like helium.)

The H atom has only a single electron which is located in the first shell. Lithium, Li, is the next element in the alkali metals and it has three electrons. However, only one of these is in the outer valence shell, the other two are in the "closed" first shell. A shell is said to be closed when it acquires a noble gas configuration. The two inner electrons are never involved in the chemical reactions of Li. Likewise

sodium, Na, has a single valence electron located in the third shell and the other electrons (two located in the first shell and eight in the second shell) are never involved in chemical reaction. Thus atoms with similar properties have similar structures and are located in columns called groups or families in the periodic table.

To write a Lewis symbol for an atom, place the atom's chemical symbol in the center. This symbol will be the atomic core and will represent the nucleus and inner electrons for that atom. The valence electrons will be represented as a dot. Dots are placed around the atomic core singly for the first four electrons. For the subsequent four, the dots are paired.

The number of valence electrons for the primary elements is equal to the number heading for the column in which the atom is found. For example, carbon is in group 4, so it has 4 valence electrons. The trends for the outer electrons are clearly demonstrated in the Lewis Periodic Table shown below.

**Lewis Periodic Table Showing Outer Shell (Valence) Electrons**

1	2	3	4	5	6	7	8
H•							•He•
Li•	•Be•	•B•	•C•	•N•	•O•	•F•	•Ne•
Na•	•Mg•	•Al•	•Si•	•P•	•S•	•Cl•	•Ar•
K•	•Ca•	•Ga•	•Ge•	•As•	•Se•	•Br•	•Kr•
Rb•	•Sr•	•In•	•Sn•	•Sb•	•Te•	•I•	•Xe•
Cs•	•Ba•						







The shape of a molecule depends on the number of atoms around a central atom and their bond angles and the lone pairs of electrons on the central atom. Lone pair electrons and bond pair electrons repel one another. So the electrons will arrange themselves around the central atom as far apart as possible in order to minimize repulsion. This theory is known as Valence Shell Electron Pair Repulsion Theory or VSEPR theory. The most common molecular shapes are shown in the table below.

Bonding orbitals form when the valence orbitals on two atoms share a pair of electrons. The resulting orbital is called a "localized bonding orbital." It is called "localized" because the electron cloud lies primarily between the two bonded atoms. The overlap called "hybridization" is a combination of s orbitals with p and possibly d orbitals. Hybridization for the central atom is determined by the total number of electron groups which consists of the number of bonding groups plus the number of lone pairs. The hybridizations for the number of electron groups are as follows:

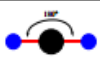
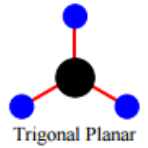
hybridization	electron groups
sp	2
sp <sup>2</sup>	3
sp <sup>3</sup>	4
sp <sup>3</sup> d	5
sp <sup>3</sup> d <sup>2</sup>	6

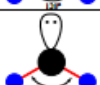
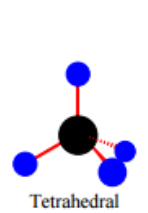
An easy way to remember the hybridization is that the number of letters in the hybridization equals the number of electron groups. For example, sulfur hexafluoride has 6 electron groups and the number of letters s, p, p, p, d, & d is 6.

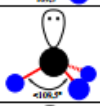
## Using VSEPR to Predict the Shapes of Molecules

Electron Groups on central atom <sup>1</sup>	Electron-Group Shape	Bonds <sup>2</sup>	Lone Pairs	$AX_mE_n$ <sup>3</sup>	Molecular Shape	Bond angles	Polarity	Hybrid-ization	Appearance
2	 Linear	2	0	$AX_2$	linear	$180^\circ$	nonpolar <sup>4</sup>	sp	
3	 Trigonal Planar	3	0	$AX_3$	trigonal planar	$120^\circ$	nonpolar <sup>4</sup>	$sp^2$	
		2	1	$AX_2E$	bent	$<120^\circ$ <sup>5</sup>	polar	$sp^2$	
4	 Tetrahedral	4	0	$AX_4$	tetrahedral	$109.5^\circ$	nonpolar <sup>4</sup>	$sp^3$	
		3	1	$AX_3E$	trigonal pyramidal	$<109.5^\circ$	polar	$sp^3$	
		2	2	$AX_2E_2$	bent	$<109.5^\circ$	polar	$sp^3$	

<sup>1</sup> "Electron groups" include bonds, lone pairs, and odd (unpaired) electrons. A multiple bond (double bond or triple bond) counts as one electron group.

<sup>2</sup> A multiple bond (double bond or triple bond) counts as one bond in the VSEPR model.

<sup>3</sup> A = central atom, X = surrounding atoms, E = lone pairs

<sup>4</sup> Molecules with this shape are nonpolar when all of the atoms connected to the central atom are the *same*. If the atoms connected to the central atom are *different* from each other, the molecular polarity needs to be considered on a case-by-case basis.

<sup>5</sup> Since electrons in lone pairs take up more room than electrons in covalent bonds, when lone pairs are present the bond angles are "squashed" slightly compared to the basic structure without lone pairs.

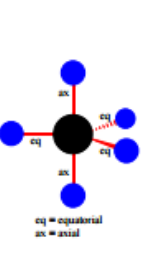
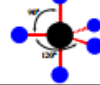
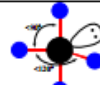
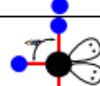
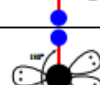
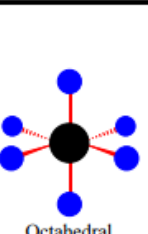
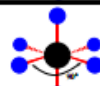
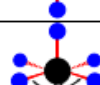
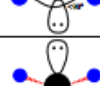
Electron Groups on central atom <sup>1</sup>	Electron-Group Shape	Bonds <sup>2</sup>	Lone Pairs	$AX_mE_n$ <sup>3</sup>	Molecular Shape	Bond angles	Polarity	Hybrid-ization	Appearance
5	 Trigonal Bipyramidal eq = equatorial ax = axial	5	0	$AX_5$	trigonal bipyramidal	$120^\circ$ eq $90^\circ$ ax	nonpolar <sup>4</sup>	$sp^3d$	
		4	1	$AX_4E$	seesaw	$<120^\circ$ eq $<90^\circ$ ax	polar	$sp^3d$	
		3	2	$AX_3E_2$	T-shaped	$<90^\circ$	polar	$sp^3d$	
		2	3	$AX_2E_3$	linear	$180^\circ$	nonpolar <sup>4</sup>	$sp^3d$	
6	 Octahedral	6	0	$AX_6$	octahedral	$90^\circ$	nonpolar <sup>4</sup>	$sp^3d^2$	
		5	1	$AX_5E$	square pyramidal	$<90^\circ$	polar	$sp^3d^2$	
		4	2	$AX_4E_2$	square planar	$90^\circ$	nonpolar <sup>4</sup>	$sp^3d^2$	

**Procedure:****Rules for Drawing Lewis Structures**

Complete the Lewis structures in the table on the datasheet. Combining atoms to form covalent molecules can be accomplished following five easy steps:

- 1.) Find the total number of valence electrons for a neutral molecule by adding up the number of valence electrons needed for each atom in the molecule. (If it is not neutral, add an electron for every negative charge and subtract an electron for every positive charge.)
- 2.) Write the atomic cores in the proper configuration.
  - a. When in doubt, start by drawing a stick structure for the molecule. Most molecules consist of one central atom bonded to 2, 3, or 4 other atoms.
  - b. The central atom will be the least electronegative (except hydrogen). The central atom usually needs to form multiple bonds and hydrogen can only form one.
  - c. The other atoms are arranged around the central atom and are initially attached with single bonds.
- 3.) Distribute the electrons for electron bonds by placing pairs of electrons between bonding atoms. (A pair of bonding electrons can also be shown jointly as a single line.) Subtract the electrons used in step 3 from those calculated in step 1.
- 4.) Assign the remaining electrons to the outer atoms to complete their octets except hydrogen which is a duet. Subtract the electrons used in step 4 from step 3.
- 5.) Assign any leftover electrons to the central atom. If the central atom now has an octet (or exceeds it), then the Lewis structure is complete. If there are not enough electrons available to obey the octet rule for the central atom, then double or triple bonds may need to be formed.

**Constructing Models, Determining Molecular Shapes and Molecular Polarity**

- 1.) Use your molecular modeling kit\* to construct a 3-dimensional model of each of these molecules and polyatomic ions. Sketch a reasonable facsimile (picture) of this model in the data table.
- 2.) Compare the model constructed to the molecular shapes in the table "Using VSEPR to Predict the Shapes of Molecules." Then identify and record the correct shape name of the molecule and its bond angles. If the molecule has not definite central atom, then record only the bond angles.
- 3.) Evaluate the polarity of the bonds in each molecule and the overall symmetry of the molecule in order to determine whether it is polar or non-polar. Nonpolar molecules will have an equal pull on the central atom by the outer atoms or the lone pairs.

**\*Molecular Modeling Kit**

- 1.) Each colored ball in your kit corresponds to a different type of atoms (or group of atoms).
 

<b>Black</b> – carbon (silicon)	<b>Dark Blue</b> – xenon (1 5-holed & 1 6-holed)
<b>Red</b> – oxygen	<b>Light Blue</b> - nitrogen
<b>White</b> – hydrogen	<b>Tan</b> - boron
<b>Green</b> – chlorine (halogens)	
<b>Purple, Silver &amp; Yellow</b> – have 1 each of the 6 holed, 5 holed & 4 holed balls.	
For phosphorus, use one of the 5-holed balls.	
- 2.) Use Tan paddle shapes for lone pairs.
- 3.) Use short sticks for single bonds. Use two long flexible sticks for double bonds and three long sticks for a triple bond.

**References:**

Aufbau Diagram available at:

<http://chemistry.tutorvista.com/inorganic-chemistry/aufbau-principle.html>

Binford, Jr., Jesse S. *Foundations of Chemistry*. Macmillan Publishing Co., Inc. New York: 1975. pp. 115-135.

Drawing Lewis Dot Structures available at:

<https://www.khanacademy.org/science/chemistry/chemical-bonds/copy-of-dot-structures/v/drawing-dot-structures>

Electron Arrangements of Atoms available at:

<http://www.ck12.org/user:bWV2YW5zQGJjc3dhbi5uZXQ./book/Mrs.-Evans-Chemistry-FlexBook/section/6.3/>

Electron Configurations available at:

<http://wps.prenhall.com/wps/media/objects/3311/3390683/blb0608.html>

Gillette, M. L. "Visualizing Chemical Structures Using Lewis Models."

Lewis, John R. *College Chemistry: A Barnes & Noble Outline*. Barnes & Noble Books. New York: 1971. pp. 24-30, 41-47.

Lewis Structures and Molecular Shapes available at:

[http://www.smc.edu/projects/28/Chemistry\\_10\\_Experiments/Ch10\\_Molecular\\_Shapes.pdf](http://www.smc.edu/projects/28/Chemistry_10_Experiments/Ch10_Molecular_Shapes.pdf)

Periodic Table of outer electrons available at: Available at:

<http://socratic.org/questions/i-need-help-in-chemistry-pls-huhu-we-have-an-exam-tomorrow-what-is-s-block-d-blo>

Pierce, Conway and R. Nelson Smith. *General Chemistry Workbook: How to Solve Chemistry Problems*, 3<sup>rd</sup> ed. W.H. Freeman and Co. San Francisco: 1965. pp. 65-71

Roberts, Jr., Julian L., J. Leland Hollenberg and James M. Postma. *Chemistry in the Laboratory*, 4<sup>th</sup> ed. W. H. Freeman & Co. New York: 1997. pp. 213-258

Tro, Nivaldo J. *Chemistry: A Molecular Approach*, 2<sup>nd</sup> ed. Prentice Hall. New York: 2011. Chapters 8 & 10.

Using VESPR to Predict the Shapes of Molecules available at:

[https://www.angelo.edu/faculty/kboudrea/index/Handout\\_Lewis\\_VSEPR.pdf](https://www.angelo.edu/faculty/kboudrea/index/Handout_Lewis_VSEPR.pdf)





# Electron Configuration & Lewis Dot Datasheets

## Part A: Electron Configuration of Elements

### Directions:

For each given element, list the number of electrons and fill in the orbital diagram on the left. Start with the bottom orbital and fill in electrons one at a time moving up the diagram and left to right. The first electron should be shown as “↑”; when the second one is added it will form an “↑↓”. Then write the electron configurations for the element in both the long form and the short form on the right. The order of electrons in the electron configuration corresponds to the orbitals moving from the bottom up.

### Example, Iron:

4s	↑↓	4p	↑↓ ↑↓ ↑↓	3d	↑↓ ↑↓ ↑↓ ↑↓
3s	↑↓	3p	↑↓ ↑↓ ↑↓		
2s	↑↓	2p	↑↓ ↑↓ ↑↓		
1s	↑↓				
Element: <b>Fe</b>					
# of electrons: <u>26</u>					

### Long Form:



### Short Form:



### 1.) Lithium

4s	○	4p	○ ○ ○	3d	○ ○ ○ ○ ○
3s	○	3p	○ ○ ○		
2s	○	2p	○ ○ ○		
1s	○				
Element: <b>Li</b>					
# of electrons: _____					

### Long Form:

Li:

### Short Form:

Li:

### 2.) Strontium

5s	○	5p	○ ○ ○	4d	○ ○ ○ ○ ○
4s	○	4p	○ ○ ○	3d	○ ○ ○ ○ ○
3s	○	3p	○ ○ ○		
2s	○	2p	○ ○ ○		
1s	○				
Element: <b>Sr</b>					
# of electrons: _____					

### Long Form:

Sr:

### Short Form:

Sr:



## 3.) Phosphorus

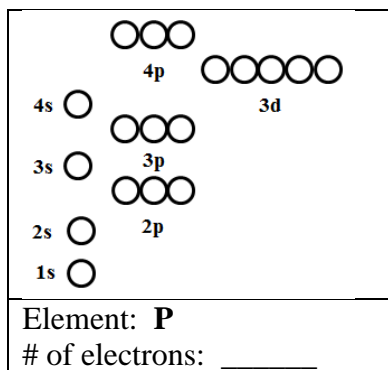

Long Form:

**P:**

Short Form:

**P:**

## 4.) Oxygen

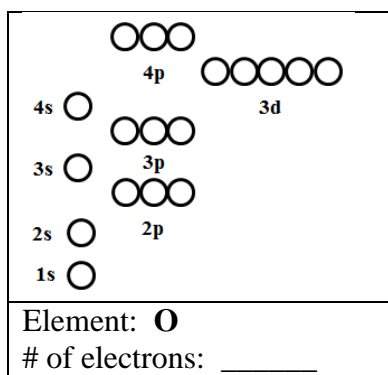

Long Form:

**O:**

Short Form:

**O:**

## 5.) Bromine

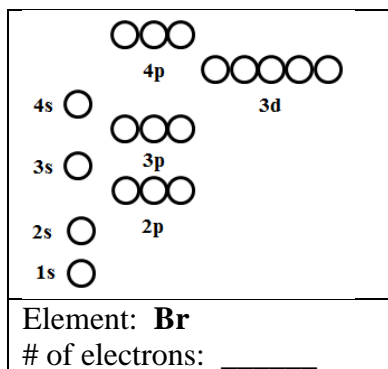

Long Form:

**Br:**

Short Form:

**Br:**



## Part B: Electron Configuration of Ions

### Directions:

For each given ion, list the number of electrons and fill in the orbital diagram on the left. Start with the bottom orbital and fill in electrons one at a time moving up the diagram and left to right. The first electron should be shown as “↑”; when the second one is added it will form an “↑↓”. Then write the electron configurations for the element in both the long form and the short form on the right. The order of electrons in the electron configuration corresponds to the orbitals moving from the bottom up. When adding electrons for anions, continue in the same way. When removing electrons for cations, work in the reverse order. (Note the exception for some transition metals ions.)

### Example, Ferrous Ion:

		○○○		○○○○○○
		4p		3d
4s	○			
		○○○○		
3s	○○○○	3p		
		○○○○		
2s	○○○○	2p		
		○○○○		
1s	○○○○			
Element: $\text{Fe}^{2+}$				
# of electrons: <u>24</u>				

Long Form:

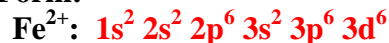

Short Form:



\*Note: 4s & 3d orbitals are extremely close in energy, this results in some irregular behavior when the transition metals form ions.

### 1.) Lithium ion

		○○○		○○○○○○
		4p		3d
4s	○			
		○○○○		
3s	○	3p		
		○○○○		
2s	○	2p		
		○○○○		
1s	○			
Element: $\text{Li}^+$				
# of electrons: _____				

Long Form:



Short Form:



### 2.) Strontium Ion:

		○○○		○○○○○○
		5p		4d
5s	○			
		○○○○		
		○○○○		
4s	○	4p		3d
		○○○○		
3s	○	3p		
		○○○○		
2s	○	2p		
		○○○○		
1s	○			
Element: $\text{Sr}^{2+}$				
# of electrons: _____				

Long Form:



Short Form:





## 3.) Phosphide Ion:

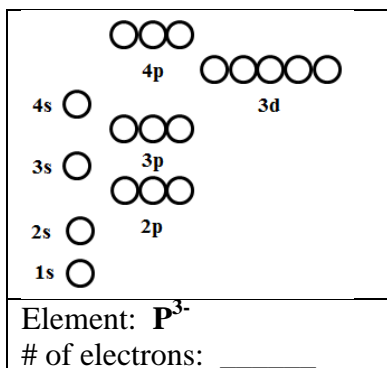

Long Form:



Short Form:



## 4.) Oxide Ion:

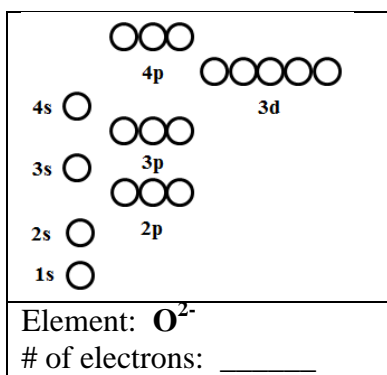

Long Form:



Short Form:



## 5.) Bromide Ion:

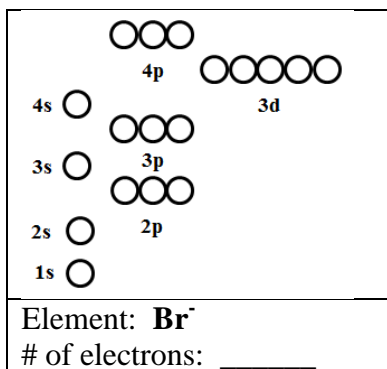

Long Form:



Short Form:







### Part C: Lewis Symbols of Atoms

#### Directions:

For each given element, list the number of **valence** electrons (*outershell electrons only*). Then write the Lewis symbol indicating the appropriate number of valence electrons with Lewis dots.

Element	Chemical Symbol	Number of Valence Electrons	Lewis Symbol
<b>Fluorine</b>	<b>F</b>	<b>7</b>	
Lithium	Li		
Strontium	Sr		
Phosphorus	P		
Oxygen	O		
Bromine	Br		



### Part D: Lewis Symbols of Monoatomic Ions

#### Directions:

For each given ion, list the number of **valence** electrons (*outershell electrons only*). Then write the Lewis symbol indicating the appropriate number of valence electrons with Lewis dots. F<sup>-</sup>

Ion	Chemical Symbol	Number of Valence Electrons	Lewis Symbol
<b>Fluoride</b>	<b>F<sup>-</sup></b>	<b>8</b>	<b>[<math>\cdot\cdot\text{F}\cdot\cdot</math>]<sup>-</sup></b>
Lithium	Li <sup>+</sup>		
Strontium	Sr <sup>2+</sup>		
Phosphide	P <sup>3-</sup>		
Oxide	O <sup>2-</sup>		
Bromide	Br <sup>-</sup>		

