

Physics 2145 Spring 2019 Test 1 (4 pages)

Name: _____ February 22, 2019 Total Score: _____/120

Constants: electron mass $m_e = 9.11 \times 10^{-31}$ kg proton mass $m_p = 1.67 \times 10^{-27}$ kg

$e = 1.602 \times 10^{-19}$ C $\epsilon_0 = 8.85 \times 10^{-12}$ C²/N•m² $k = 9.0 \times 10^9$ N•m²/C²

$$F = k \frac{|q_1 q_2|}{r^2} \quad E = k \frac{|q|}{r^2} \quad \vec{F} = q\vec{E} \quad U = k \frac{q_1 q_2}{r} \quad V = k \frac{q}{r} \quad U = qV$$

$$C = \frac{Q}{\Delta V} \quad C = \kappa \epsilon_0 \frac{A}{d} \quad \Delta V = Ed \quad U = \frac{1}{2} Q \Delta V = \frac{1}{2} C (\Delta V)^2 = \frac{1}{2} \frac{Q^2}{C}$$

$$K = \frac{1}{2} m v^2 \quad \Delta K = -q \Delta V \quad \text{parallel: } C_{eq} = \sum_i C_i \quad \text{series: } \frac{1}{C_{eq}} = \sum_i \frac{1}{C_i}$$

____ 1.(5) The figure shows a point. Which of the following is true about the of the electric potentials V_1 and V_2 and the electric field strengths E_1 and E_2 at the two points, respectively?

- A) $V_1 = V_2$ and $E_1 = E_2$ B) $V_1 = \frac{1}{3} V_2$ and $E_1 = \frac{1}{3} E_2$
 C) $V_2 = \frac{1}{3} V_1$ and $E_2 = \frac{1}{3} E_1$ D) $V_2 = \frac{1}{3} V_1$ and $E_2 = \frac{1}{9} E_1$

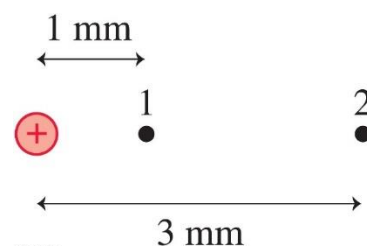

____ 2. (5) Object A has a charge of +2 C and object B has a charge of +4 C. Which is true?

- A) $\vec{F}_{B \text{ on } A} = 2\vec{F}_{A \text{ on } B}$ B) $\vec{F}_{B \text{ on } A} = -\vec{F}_{A \text{ on } B}$
 C) $\vec{F}_{B \text{ on } A} = -2\vec{F}_{A \text{ on } B}$ D) $\vec{F}_{B \text{ on } A} = \frac{1}{2}\vec{F}_{A \text{ on } B}$

____ 3. (5) Which of the following is **FALSE**?

- A) Electric field lines are perpendicular to equipotential surfaces.
 B) The electric field points towards higher potential.
 C) The surface of a conductor in electrostatic equilibrium is an equipotential surface.
 C) The field inside a conductor in electrostatic equilibrium is zero.

____ 4.(5) An electric dipole is placed in a uniform electric field. Which is true?

- A) The net force on the dipole increases if the electric field strength increases.
 B) The net torque on the dipole is always zero.
 C) The dipole wants to align so that the dipole moment is perpendicular to the electric field.
 D) A dipole in a uniform electric field experiences zero net force.

____/20 points for this page

5. (40) A parallel plate capacitor consists of two circular plates of radius 10cm that are spaced 2mm apart with air between the plates. The potential difference between the plates is 600 V.

a) (5) Calculate the capacitance.

b)(5) Calculate the amount of charge stored on each plate.

c) (5) Calculate the electric field between the plates.

d) (5) If the voltage difference between the plates is doubled, which of these quantities remains unchanged? Circle the correct answer.

Charge

Capacitance

Electric field

e) (15) An electron is released from the negative plate and accelerates towards the positive plate. It strikes the positive plate with a speed of 2.0×10^7 m/s. What was the electron's speed when it left the negative plate?

f) (5) During this process, what is the electron's change in kinetic energy **in electron volt**?

____/40 points for this page

6. (20) For the capacitor circuit in the figure,
 $C_1 = 6 \text{ nF}$, $C_2 = 12 \text{ nF}$, $C_3 = 4 \text{ nF}$, and $C_4 = 8 \text{ nF}$.

a)(15) Find the equivalent capacitance.

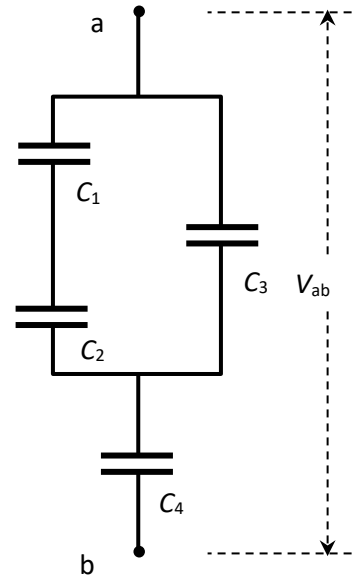

b) (5) If the applied voltage $V_{ab} = 20\text{V}$, find the total charge on the system.

___/20 points for this page

7) (40) Two charges, $q_1=+3.0\text{nC}$ and $q_2=-3.0\text{nC}$, are located as shown in the figure. Charge q_2 is located on the x -axis at $x= 6.0\text{cm}$. Charge q_1 is at $x= 6.0\text{cm}$, $y=8.0\text{cm}$.

a)(5) At the origin, draw the electric field vectors created by each of the charges.

b)(10) Calculate the magnitudes of the electric fields created by each of the charges at the origin.

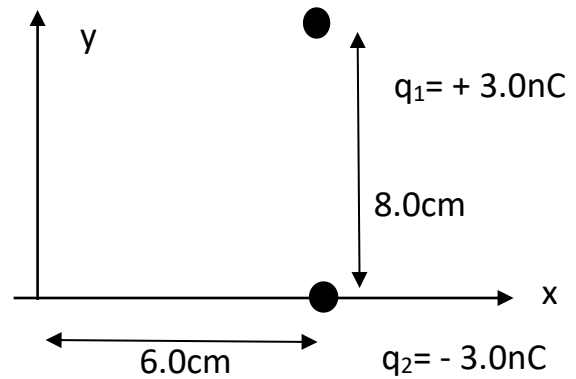

c)(10) Calculate the x - and y - components of the net electric field at the origin.

d)(5) Calculate the magnitude of the net electric field at the origin.

e)(10) Calculate the electric **potential** at the origin.

____/40 points for this page