

Physics 24 Exam 2

March 18, 2014

Exam Total

/ 200

Printed Name: _____

Rec. Sec. Letter: _____

Five multiple choice questions, 8 points each. Choose the **best** or **most nearly correct** answer.

_____ 1. You need to store electrical energy with a simple parallel plate capacitor of fixed plate area A_0 and separation d_0 . Which of the following configurations stores the most energy?

- [A] capacitor voltage equals V and dielectric with $\kappa = 3$ between the plates
- [B] capacitor voltage equals $2V$ and dielectric with $\kappa = 1.5$ between the plates
- [C] capacitor voltage equals $3V$ and dielectric with $\kappa = 1$ between the plates
- [D] capacitor voltage equals $2V$ and dielectric with $\kappa = 2$ between the plates

_____ 2. If the current through an ohmic resistor is doubled, which of the following is true?

- [A] The power dissipated by the resistor doubles and the resistance doubles.
- [B] The power dissipated by the resistor quadruples and the resistance doubles.
- [C] The power dissipated by the resistor doubles and the resistance is unchanged.
- [D] The power dissipated by the resistor quadruples and the resistance is unchanged.

_____ 3. Your car's intermittent windshield wipers are based on an RC timing circuit. It has a fixed capacitor and a variable resistor, and executes one wiper sweep every τ seconds, where τ is the RC time constant. If you want to decrease the time between wiper sweeps you should

- [A] increase the resistance
- [B] decrease the resistance.

_____ 4. A proton moves through a region of space that has both a uniform electric field and a uniform magnetic field. The direction of the magnetic field is shown in the diagram. In order for the proton to move through this region with a constant velocity, the direction of the electric field must be

- [A] \downarrow
- [B] \uparrow
- [C] \otimes
- [D] \odot

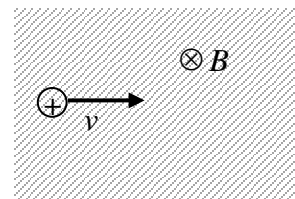

_____ 5. What would you name the movie that this picture was taken from?

- [A] Attack of the Flying Dogs
- [B] Dawn of the Flying Dogs
- [C] Flight of the Living Dogs
- [D] Flying Dogs Versus Zombies



6. (10 points total) A battery has an emf of 12 V and an internal resistance of $2\ \Omega$. You connect an external resistor of resistance R across the terminals of the battery and observe that the total power dissipated in the circuit is 18 W. Find R .

7. (30 points total) An air-filled parallel-plate capacitor consists of two circular plates of radius R_0 and plate separation d_0 . It is charged to an initial voltage V_0 .

(a) (10 points) Calculate the energy U_0 stored in the capacitor in terms of R_0 , d_0 , V_0 , and constants.

(b) (20 points) The capacitor is disconnected from the battery. After that, the plates are slowly pulled apart until their distance is $5d_0$. Find the work done by the external force that pulled the plates apart. You may express your answer in terms of R_0 , d_0 , and V_0 , and/or the initial energy U_0 .

8. (40 points total) In the circuit shown, a total current of 4A comes out of the battery. The current through resistor R_1 is 2A. The electrical power dissipated by resistor R_1 is 16.0 W. Find R_1 , R_2 , and the emf ε of the battery. Make sure to clearly draw a box around your three answers.

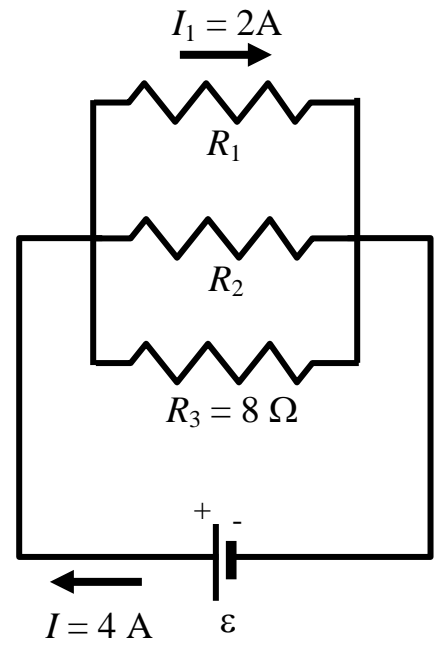

9. (40 points total) In the circuit shown with a resistance R , capacitance C , and voltage source ϵ , the capacitor is initially uncharged.

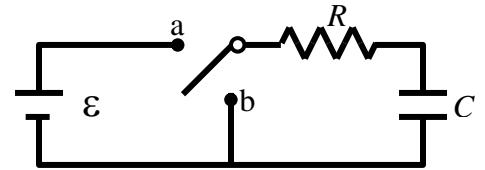

(a) (15 points) The switch is set to position “a” at time $t = 0$. Derive the expression for the current, $I(t)$, through the resistor R , at time t , in terms of R , C , ϵ , and t .

(b) (15 points) If $\epsilon = 10\text{V}$ what is the voltage across the capacitor when $t = 2 RC$?

(c) (10 points) After a long time, the capacitor fully charges to a value of $5 \mu\text{C}$. Then the switch is set to position “b.” What is the charge on the capacitor when the voltage across the capacitor drops to 2V ?

10. (20 points) A beam of positive ions moves in a clockwise orbit with a 10.0 cm radius inside a uniform 0.500 T magnetic field pointing out of the page, as shown in the figure below. The ions have a mass of 6.64×10^{-27} kg and a speed of 4.82×10^6 m/s.

(a) (15 points) What is the charge on each ion?

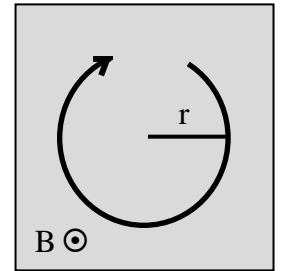

(b) (5 points) According to your answer for part (a), how many electrons were removed from each neutral atom to produce an ion?

11. (20 points) A square loop made of a single turn of current-carrying wire is oriented vertically with its top half in a uniform magnetic field and is found to hover in midair. The loop has a total mass m , side length L , and carries a current I . Find the magnitude B of the magnetic field. Express your answer in terms of m , L , I , and any necessary constants.

