

Physics 2135 Final Exam

May 11, 2016

Exam Total
/ 200

Printed Name: _____

Rec. Sec. Letter: _____

1. (40 points total) A positive point charge Q is fixed at the origin, located on one corner of a rectangle of height a and width b , as shown. Express your answers below in terms of a , b , Q , and any fundamental constants (left in symbolic form) that are required.

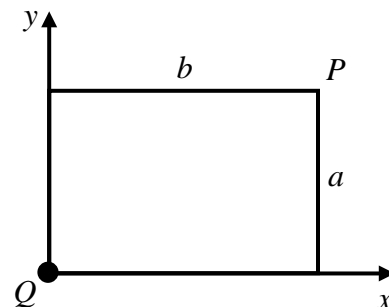

(a) (10 points) Find the x component of the electric field produced by the charge Q at the opposite corner of the rectangle, labeled point P in the diagram.

(b) (10 points) Find the y component of the electric field produced by the charge Q at the same point P as in part (a).

(c) (10 points) A second identical charge is placed on the y -axis as shown. Find the electric field at P produced by this second charge. Express your answer in unit vector notation.

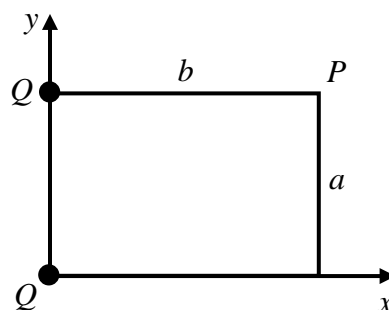

(d) (10 points) A proton of charge e is placed at point P . Find the total electric force on the proton due to the other two charges. Express your answer in unit vector notation in terms of a , b , Q , e , and any fundamental constants (left in symbolic form) that are required.

_____/40 for page 1

2. (20 points total) In the circuit $R_1=6\ \Omega$, $R_2=3\ \Omega$, $R_3=4\ \Omega$, the emf of the battery is 21 V, and the battery has an internal resistance of 1 Ω .

(a) (5 points) What is the equivalent resistance of R_1 , R_2 , and R_3 ?

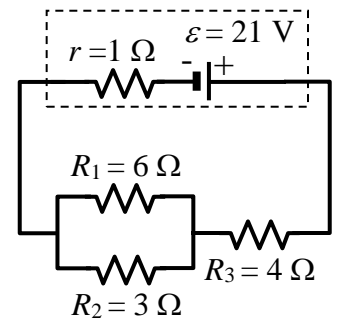

(b) (5 points) What is the current through R_3 ?

(c) (5 points) How much power is being dissipated in the 3 Ω resistor?

(d) (5 points) What is the terminal voltage of the battery?

3. (20 points total) A rectangular circuit of length $L = 50$ cm and width $W = 30$ cm is moving at a constant speed of $v = 6$ m/s and has a resistance $R = 3 \Omega$. There is a rectangular region of space containing a constant magnetic field $B = 4$ T. The width of this region is considerably larger than W .

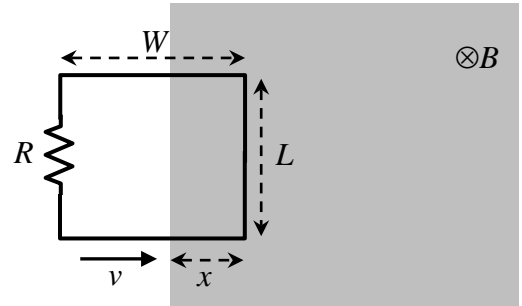

(a) (4 points) Starting with an OSE, derive an expression for the current in the circuit when it has moved a distance x into the region of space containing the magnetic field. Then calculate a numerical value for the current.

(b) (4 points) What is the direction of the current? (circle one of the arrows)

(c) (4 points) What is the magnitude of the force on the right hand side of the circuit?

(d) (4 points) What is the direction of that force? (circle one of the arrows below)



(e) (4 points) What is the current in the circuit when the circuit is totally within the magnetic field?

4. (40 points total) A *positively* charged particle with mass M and charge $+e$ moves in a circular orbit with radius R in a uniform **magnetic field directed perpendicular to the page**. The figure shows the direction of the particle's motion (in the plane of the page) at a particular instant in time. The particle completes three full circular orbits in a time interval equal to $5t_0$.

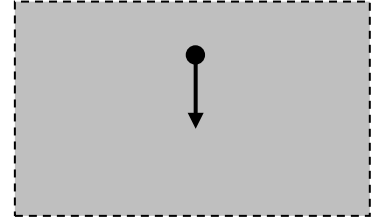

magnetic field is directed perpendicular to the page within the shaded region

(a) (10 points) Determine the speed of the particle in the magnetic field in terms of parameters given.

(b) (20 points) Determine the magnitude of the magnetic field in terms of M , e , R and t_0 .

(c) (10 points) If particle's orbit is clockwise, what is the direction of the magnetic field? (circle one of the two symbols below)



_____/40 for page 4

5. (20 points total) A particular lens has an index of refraction of $n = 1.60$ and radii of curvature of $R_1 = -20.0$ cm and $R_2 = 30.0$ cm.

(a) (10 points) Find the focal length of the lens. Start with an OSE.

(b) (5 points) Based on your answer to part (a), this lens is: (circle one below)

CONVERGING

DIVERGING

(c) (5 points) An object is placed 30 cm to the left of the lens as shown below. Draw a ray diagram, showing at least two principal rays, both focal points, and the image location.

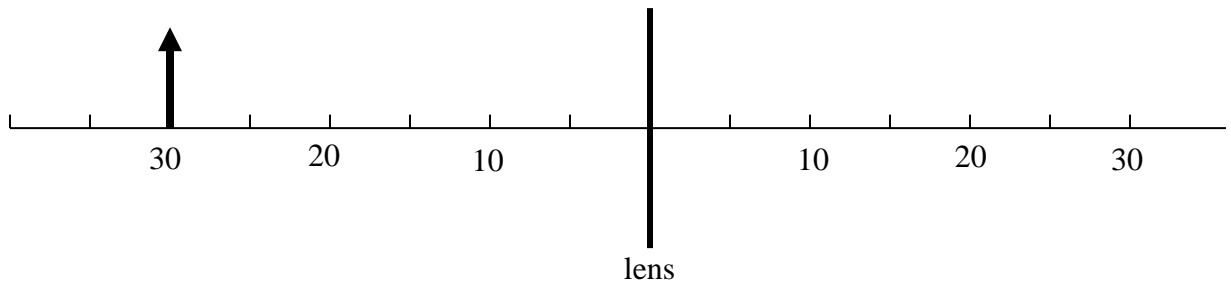

6. (20 points total) An object is placed 15.0 cm away from a converging lens with a focal length of 9.0 cm. (Note: this is not a continuation of problem 5!)

(a) (10 points) Find the image distance. Start with an OSE.

(b) (5 points) Based on your answer to part (a) the image is: (circle one) REAL VIRTUAL

(c) (5 points) Based on your answer to part (a) the image is: (circle one below)

UPRIGHT

INVERTED

7. (25 points total) You hold a reflecting sphere (for example, a Christmas tree ornament) with your eye 175 mm from the **center of the sphere**. The sphere has a radius of 50 mm magnitude.

(a) (10 points) Find the image distance for the image of your eye.

(b) (5 points) Based on your answer to part (a), is the image VIRTUAL or REAL? (Circle one)

(c) (10 points) Find the magnification of the image.

8. (15 points total) A flat, transparent solid with index of refraction $n_S = 1.4$ is immersed in a liquid of unknown index of refraction n_L . If light traveling in the liquid undergoes total internal reflection for incident angles of 60° and greater, what is n_L ?

